

2012  
Statewide Emergency Shelter  
Plan


January 31, 2012




Rick Scott  
Governor



Bryan W. Koon  
Director

<b>Table of Contents</b>		<b>Page</b>
Table of Contents		
List of Tables and List of Appendices		
Executive Summary		i
<b>1.0</b>	<b>INTRODUCTION</b>	1-1
1.1	Purpose of Statewide Emergency Shelter Plan	1-1
1.2	Background and Chronology	1-1
1.3	Statutory Considerations	1-3
<b>2.0</b>	<b>EDUCATIONAL FACILITIES AS EMERGENCY SHELTERS</b>	
2.1	Public Shelter Design Criteria	2-1
2.2	Exemption Criteria	2-2
2.3	Exemption Process	2-9
2.4	Estimate of School District Compliance with EHPA Code (2010-2011)	2-10
<b>3.0</b>	<b>REGIONAL HURRICANE EVACUATION SHELTER REQUIREMENTS</b>	3-1
3.1	Methodology for Calculating Regional and County Hurricane Evacuation Shelter Status	3-2
3.2	Location and Square Footage of Existing and Needed Shelters	3-4
3.3	Pet-Friendly Shelter Availability	3-4
<b>4.0</b>	<b>TYPES OF PUBLIC FACILITIES THAT SHOULD COMPLY WITH PUBLIC SHELTER DESIGN CRITERIA</b>	4-1
4.1	Public Schools and Community Colleges	4-1
4.2	Charter Schools	4-2
4.3	State Universities	4-2
4.4	State and Local Public Facilities	4-3
<b>5.0</b>	<b>RECOMMENDED SOURCES OF FUNDING</b>	5-1
5.1	Public Schools, Community Colleges and University Facilities	5-1
5.2	Hurricane Hazard Mitigation Funds	5-4
<b>6.0</b>	<b>STATEWIDE PROGRESS TOWARD ELIMINATING THE PUBLIC HURRICANE EVACUATION SHELTER SPACE DEFICIT</b>	6-1
<b>7.0</b>	<b>CONCLUSIONS</b>	7-1
<b>APPENDICES</b>		

## List of Appendices

- Appendix A:  List of Hurricane Evacuation Shelters by County, Location and Capacity
- Appendix B: 2010 FBC—Building, Section 423.25 Public Shelter Design Criteria
- Appendix C: ARC 4496 - Standards for Hurricane Evacuation Shelter Selection
- Appendix D: Acronyms
- Appendix E: Glossary
- Appendix F: Mass Care Standards and Indicators, Version 011-072209
- Appendix G: Guidance for Implementation of Public Shelter Design Criteria
- Appendix H: Hurricane Evacuation Shelter Net Usability Multiplication Factor Estimates for Department of Education Facilities
- Appendix I: Department of Education Memorandum on Hurricane Shelters in New Educational Facilities, dated October 31, 2001
- Appendix J: Hurricane Shelter Demand Study Table
- Appendix K: Guidance for Selection of Impact Resistant Constructed Wall and Roof Assemblies
- Appendix L: The ADA and Emergency Shelters: Access for All in Emergencies and Disasters

## List of Tables

	<b>Page</b>
Table EX-1: Regional Summaries of Hurricane Shelter Demand, Capacities, and Deficits/Surpluses	ii
Table 2-1: Estimate of Local Compliance with EHPA Requirements	2-12
Table 3-1: Shelter Demand/Capacity In People	3-6
Table 3-2: Shelter Demand/Capacity In Square Feet	3-11
Table 5-1: Estimate of PECO Funds Distributed to School Districts 1997-2012 Comparison to EHPA Spaces Created	5-1
Table 6-1: Hurricane Shelter Deficit Reduction Cumulative Progress (1995-2012)	6-3

<b>List of Tables (Cont'd)</b>	<b>Page</b>
Table G-1: Wind Design Factor Comparisons for ICC 500, 2004 EHPA and 2010 EHPA	G-4
Table G-2: Equivalent Basic Wind Speed Conversions	G-5
Table G-3: Florida Shelter Occupant Space Calculation Recommendations with FNSS for Dormitory Area	G-18
Table G-4: Estimate of Minimum Daily Drinking Water Needs in Unconditioned Shelters	G-19
Table G-5: Comparison of Florida's EHPA to the International Code Council's ICC 500	G-24
Table K-1: Windborne Debris Impact Criteria Comparisons for Vertical Surfaces	K-6
Table K-2: Windborne Debris Impact Criteria Comparisons for Horizontal Surfaces	K-7
Table K-3: Windborne Debris Impact Resistant Wall Assemblies	K-8
Table K-3: Windborne Debris Impact Resistant Roof Assemblies	K-14

### **List of Figures**

Figure 2-1: Regional Hurricane Evacuation Shelter Space Surplus/Deficit Status of General Population Shelters	2-7
Figure 2-2: Regional Hurricane Evacuation Shelter Space Surplus/Deficit Status of General Population Shelters	2-8
Figure 3-1: Regional Planning Council (RPC) Regions of Florida	3-1
Figure 3-2: Florida Counties with Designated Pet-Friendly Shelters	3-5
Figure 6-1: Projected Hurricane Shelter Deficit Reduction	6-7
Figure G-1: ASCE 7-2010 and 2010 Florida Building Code—Building, Risk Category II Design Wind Speed Map	G-6
Figure G-2: ASCE 7-2010 and 2010 Florida Building Code—Building, Risk Category IV Design Wind Speed Map	G-7



**List of Figures (Cont'd)**

Page

Figure G-3: ICC 500 Hurricane Design Wind Speed Map

G-8

Figure G-4: 10,000-year High Wind Recurrence Map for Florida

G-8

## EXECUTIVE SUMMARY

Pursuant to §1013.372(2) and §252.385(2)(b), Florida Statutes, (Fla. Stat.) the Division of Emergency Management (Division) is responsible for preparing a *Statewide Emergency Shelter Plan* (the Plan). The Plan is a guide for local emergency planning. It also provides advisory assistance to school districts contemplating construction of educational facilities and the need to provide public shelter space within those facilities. The Plan is submitted to the Governor and Cabinet for approval by January 31 of each even-numbered year. The Plan identifies the general location and square footage of both general population and special needs shelters (SpNS), by Regional Planning Council (RPC) region, during the next five (5) years. The Plan also includes information on the availability of shelters that accept pets. The Department of Health assists the Division in determining the estimated need for hurricane evacuation shelter space and the adequacy of facilities to meet the needs of persons with special needs. In accordance with the statute, the Plan must:

- Identify the general location and square footage of existing shelters by RPC regions;
- Identify the general location and square footage of needed shelters by RPC regions for the next five years;
- Identify the types of facilities which should be constructed to comply with the public shelter design criteria; and
- Recommend an appropriate and available source of funding for the additional cost of constructing emergency shelters within those public facilities.

With publication of the 2006 Plan, the Division began monitoring the status of the statewide inventory of SpNS. Historically, SpNS have been included in total population hurricane evacuation shelter demand estimates, hurricane evacuation shelter capacities and surplus/deficit results. Given the findings from the 2004 hurricane season where about half of the designated SpNS were located in facilities that did not meet the same minimum hurricane safety criteria as general population shelters, the Division was asked to separate the two shelter types (general population and special-needs) and monitor progress towards improving SpNS hurricane safety, client capacity and provision of emergency power supported air-conditioning.

Table EX-1 provides a regional summary of the projected regional hurricane evacuation shelter space demands for 2012 and 2017, indicates the quantity of recognized hurricane evacuation shelter spaces per region, and indicates whether or not there is a surplus or deficit of spaces per region. At this time, eight (8) RPC regions have a surplus of general population hurricane evacuation shelter space in 2012 (West Florida/Region 1, Apalachee/Region 2, North Central Florida/Region 3, East Central Florida/Region 6, Central Florida/Region 7, Tampa Bay/Region 8, Treasure Coast/Region 10 and South Florida/Region 11). Only four (4) regions have a surplus of SpNS space in 2012 (Regions 1, 5, 6 and 11).

**Table EX-1.**  
**Regional Summaries of Hurricane evacuation shelter Demand, Capacities, and Deficits/Surpluses for 2012 through 2017**  
**General Population and Special Needs Shelters**

RPC Region	RPC Region Name	General Population Shelter Demand and Capacities					Special Needs Shelter Demand and Capacities				
		2012 Cat. 5 Shelter Demand, persons	2017 Cat. 5 Shelter Demand, persons	2012 Shelter Capacity, persons	2012 Shelter Surplus/ (Deficit), persons	2017 Shelter Surplus/ (Deficit), persons	2012 Cat. 5 Shelter Demand, clients	2017 Cat. 5 Shelter Demand, clients	2012 Shelter Capacity, clients	2012 Shelter Surplus/ (Deficit), clients	2017 Shelter Surplus/ (Deficit), clients
1	West Florida (WF)	35,381	39,317	72,691	37,310	33,374	1,328	1,422	2,260	932	838
2	Apalachee (APAL)	9,691	10,117	33,680	23,989	23,563	3,524	3,717	814	(2,710)	(2,903)
3	North Central Florida (NCF)	28,747	30,046	30,773	2,026	727	1,679	1,758	1,062	(617)	(696)
4	Northeast Florida (NEF)	89,323	99,852	75,398	(13,925)	(24,454)	5,959	6,523	3,717	(2,242)	(2,806)
5	Withlacochee (WITH)	61,899	69,244	31,702	(30,197)	(37,542)	267	298	2,530	2,263	2,232
6	East Central Florida (ECF)	139,786	167,388	158,947	19,161	(8,441)	999	1,202	8,205	7,206	7,003
7	Central Florida (CF)	45,295	48,708	55,571	10,276	6,863	4,726	5,154	1,515	(3,211)	(3,639)
8	Tampa Bay (TB)	134,333	138,565	185,083	50,750	46,518	14,885	15,628	6,998	(7,887)	(8,630)
9	Southwest Florida (SWF)	102,580	112,661	22,465	(80,115)	(90,196)	8,860	9,781	1,726	(7,134)	(8,055)
10	Treasure Coast (TC)	42,219	45,604	117,591	75,372	71,987	11,598	12,534	3,251	(8,347)	(9,283)
11	South Florida (SF)	87,855	91,269	118,413	30,558	27,144	4,085	4,343	5,003	918	660
	<b>TOTALS</b>	<b>777,109</b>	<b>852,770</b>	<b>902,314</b>	<b>125,205</b>	<b>49,544</b>	<b>57,910</b>	<b>62,361</b>	<b>37,081</b>	<b>(20,829)</b>	<b>(25,280)</b>

ii:

Based upon currently available information, surpluses of general population space will continue in RPC regions 1, 2, 3, 7, 8, 10 and 11 through 2017. Region 6 may return to a deficit situation if an inadequate quantity of hurricane evacuation shelter space is added to the regional inventory over the next two (2) to five (5) years. The SpNS regional hurricane evacuation shelter space deficit situation is projected to remain the same through 2017 with seven (7) regions in deficit. It should be noted that these projections do not assume addition of new space to regional inventories. Addition of new space could significantly reduce or eliminate the projected deficits. As demonstrated in Table EX-1, seven (7) regions currently have SpNS client space deficits.

A comparison of both general population and SpNS indicates that only two (2) regions have a hurricane evacuation shelter space surplus for both shelter types: RPC regions 1 and 11. All other regions and their respective district school boards, community colleges and universities are required to construct new educational facilities in compliance with public shelter design criteria.

The types of public facilities that should be constructed to comply with the public shelter design criteria include all facilities that are subject to be used as public hurricane evacuation shelters under the authority of §252.385(4)(a), Fla. Stat.; that is, public schools, community colleges, universities, and other facilities owned by state and local governments. When appropriately located, designed and constructed, the following types of facilities are normally considered suitable for use as public hurricane evacuation shelters:

Community and civic centers, meeting halls, gymnasiums, auditoriums, cafeterias and open floor multipurpose facilities, exhibition halls, sports arenas, field houses, conference and training centers, certain classroom buildings, and other public assembly facilities.

The types of facilities that are not appropriate for use as public shelters are due to the following elements:

- location (facilities within Category 1, 2 or 3 hurricane evacuation zones, and possibly Category 4 and 5, flooding isolation, presence of certain hazardous materials, low evacuation demand, etc.),
- size (e.g., less than 2,000 square feet of usable floor area), or
- other characteristics (incompatibility of facility's normal use or availability with mass care function, long-range planning considerations, etc.).

During preparation of this Plan, the Division conducted a survey to estimate the compliance rate of school districts adhering to the statutory and code requirements of the public shelter design criteria for new school facilities construction. The Division wanted to determine if compliance with the existing law had improved since 2001. In 2001, the State Auditor General had a finding that, of the new schools reviewed, only 65 percent appeared to comply with the public shelter design criteria. Between 2001 and 2009 the Division observed a similar compliance rate of 65 percent. However, a more recent survey indicated improved compliance.

According to the Florida Inventory of School Houses (FISH) data, there were 60 new school buildings constructed between 2010 and 2011, with an estimated total net floor area of



1,414,586 square feet. The Division recognizes 26 of those facilities (640,884 square feet) as meeting the public shelter design criteria, and another 29 buildings (692,790 square feet) were lawfully exempt for statutory and code provided causes. Therefore, the applicable school districts had a compliance rate of better than 90 percent.

District school boards have generally been reporting that the construction cost premium for incorporating the criteria is about four (4) percent. This is not necessarily an insignificant cost that must be borne by state and local agencies. Therefore, §1013.372(2), Fla. Stat. requires that the Division recommend an appropriate and available source of funding for the additional cost of constructing emergency shelters. The Division recommends the use of existing capital outlay funds as they are an appropriate and available source of state funding.

The Public Education Capital Outlay (PECO) is the only existing state capital outlay fund available to support hurricane evacuation shelter construction in new public schools. PECO funds are appropriated for site acquisition and improvements necessary to accommodate buildings, equipment, and other structures of district school boards, community colleges and universities. The Department of Education has distributed about \$1,877,969,362 in new construction funds to district school boards since promulgation of the public shelter requirement into code in 1997. Other state sources of school construction funding have included Classroom For Kids (CFK), General Revenue and Lottery funds. From time to time, Federal and State hazard mitigation-related grant funds may be available to support the construction cost premium for improving hurricane resistance above minimum code requirements. However, the mitigation funds are not considered normally “available” for most new construction projects, since their grant cycles are often associated with disaster declarations.

The Division has statutory duty and authority to administer a statewide program to eliminate the deficit of “safe” hurricane evacuation shelter space. To ensure consistency with state and national standards, guidelines and “best practices,” the Division has recognized *Standards for Hurricane Evacuation Shelter Selection* (ARC 4496) as the minimum hurricane evacuation shelter survey criteria. Therefore, at a minimum, meeting ARC 4496 criteria is a required condition for a public facility to be described as “safe,” “suitable” or “appropriate” during preparation of this Plan.

To accomplish this duty, the Division has implemented a multifaceted program. This program includes: 1) survey of existing buildings, both public and private, to identify suitable shelter capacity; 2) where cost effective (and practical), support mitigation and retrofitting of existing facilities to increase shelter capacity; 3) construction of new facilities to meet the public shelter design criteria; 4) shelter demand reduction through improved hurricane hazard models and behavioral studies; and 5) improve public information/education to reduce unnecessary “shadow” evacuations.

While regional deficits do remain, Florida’s deficit of hurricane evacuation shelter space on a statewide aggregate basis has now been eliminated. The Division’s hurricane evacuation shelter survey and retrofit program identified, created or otherwise documented 459,083 hurricane evacuation shelter spaces that meet ARC 4496 guidelines. Public school new construction programs have created an additional 480,312 hurricane evacuation shelter spaces. Therefore, by the 2012 hurricane season, Florida will have a total of 939,395 shelter spaces that

meet ARC 4496 guidelines. The perceived public shelter demand resulting from hurricane evacuation has been significantly reduced over the past 11 years due to improvements in public education and information, and more accurate storm surge/evacuation zone modeling with the use of the LiDAR (Light Detection and Ranging). The 2010 Statewide Regional Evacuation Studies (SRES) resulted in a statewide aggregate hurricane evacuation shelter space demand reduction of 604,792 spaces. Florida's hurricane evacuation shelter space demand for 2012 is 835,019.

Since publication of the *2000 Statewide Emergency Shelter Plan*, Florida now has 37 counties with demonstrable surpluses of hurricane evacuation shelter space with both general population and SpNS capacities combined. The counties with surpluses include: Bay, Bradford, Brevard, Broward, Escambia, Gadsden, Gilchrist, Hamilton, Hardee, Hendry, Hillsborough, Holmes, Indian River, Jackson, Jefferson, Lafayette, Lake, Leon, Liberty, Madison, Manatee, Martin, Miami-Dade, Okaloosa, Orange, Osceola, Palm Beach, Polk, St. Johns, St. Lucie, Santa Rosa, Seminole, Suwannee, Taylor, Union, Walton, and Washington.

As Florida's hurricane vulnerable population continues to grow, it is vitally important that construction of hurricane evacuation shelters and retrofitting of existing buildings be considered a priority. If Florida is to meet its goal of eliminating the hurricane evacuation shelter space deficit in every region of the state, the incorporation of the public shelter design criteria into new construction, retrofitting of suitable existing buildings, and continued use of improved hurricane evacuation studies and new technologies must continue to be accomplished. The overall result of full implementation of the Division's hurricane evacuation shelter deficit reduction strategy is a greater level of emergency preparedness, a more efficient capability for responding to incidents and a greater ability to meet the needs of disaster survivors.

## **1.0 INTRODUCTION**

### **1.1 Purpose of Statewide Emergency Shelter Plan**

Pursuant to §1013.372(2), and §52.385(2)(b), Florida Statutes (Fla. Stat.), the *Statewide Emergency Shelter Plan* (Plan), is prepared and submitted to the Governor and Cabinet for approval. The Plan provides information on existing and needed hurricane evacuation shelter space requirements. This information is then used by district school boards, community college boards of trustees, university boards of trustees and emergency management agencies in planning for the construction of new educational facilities to comply with the public shelter design criteria. "Board," unless otherwise specified, means a district school board, a community college board of trustees, and a university board of trustees.

This Plan, once approved, will determine which regions and counties are required to construct new educational facilities to comply with the public shelter design criteria. The Plan includes: the general location and square footage of existing general population and special needs shelters (SpNS) by region and county; the general location and square footage of needed general population and SpNS by region and county for the next five years; the types of facilities that should comply with the public shelter design criteria; and recommends an appropriate and available source of funding for the additional cost of constructing public hurricane evacuation shelters in those public facilities.

Since promulgation of the public shelter design criteria in 1997, the Division has routinely received requests for guidance on certain aspects of the criteria. Therefore, this Plan also includes advisory guidance by the Division on subjects relating to implementation of the criteria; such as, minimum mass care/human needs requirements not specified in the code, explanation of exemption criteria, etc. The guidance is not intended to be a comprehensive commentary of the criteria, but is limited to subjects pertinent to the most frequently asked questions. This Plan also includes a brief progress report of statewide hurricane evacuation shelter space deficit elimination.

### **1.2 Background and Chronology**

On August 24, 1992, Hurricane Andrew made landfall in South Florida as a Category 5 hurricane. Winds in excess of 155 miles per hour spread inland, causing catastrophic damage in Miami-Dade County and other south Florida areas. It has been estimated that 750,000 persons were ordered to evacuate coastal areas, inland flood prone areas and manufactured homes. In some cases, spontaneous (or "shadow") evacuation of persons outside of areas ordered to evacuate also occurred. Though many evacuees sought shelter in motels or the homes of family and friends, many also sought safety in public shelter facilities in the affected area, and in communities along evacuation routes throughout the state. This unprecedented relocation of Florida's residents and visitors in the face of an impending natural disaster stretched the resources of State, local, and private agencies to provide public shelter.

Post-disaster evaluations of evacuation and sheltering operations by the *Governor's Disaster Planning and Response Review Committee*, also known as the "Lewis Commission," identified the lack of adequate and appropriate public shelter space as a critical planning issue. The Lewis Commission Report served as the driving force behind the adoption of Chapter 93-211, Laws of Florida, and subsequent revisions to Chapters 235, 240 and 252, Florida Statutes. The educational facilities sections of Chapters 235 and 240 have been superseded by Chapter 1013. Based on those revisions, the Legislature stated its intent that Florida eliminate its deficit of safe public hurricane evacuation shelter space in any region of the State.

In consultation with county Boards of Commissioners, county emergency management offices and the Division of Emergency Management, the State mandated that the Department of Education develop standards for a public shelter design criteria. These criteria were incorporated into State Requirements for Educational Facilities (SREF). The new criteria were to be designed to ensure that appropriate new educational facilities can serve as public shelters for emergency management purposes. After promulgation of the criteria, all new educational facilities, or appropriate areas within facilities, for which a design contract was entered into after the effective date of the inclusion of the public shelter criteria in SREF, must be built in compliance with the criteria, unless the facility is exempted by the applicable local emergency management agency or the Division.

The Department of Education entered into a contract with the University of Florida, School of Building Construction, to prepare the shelter design criteria. The university assembled an advisory committee consisting of members from federal, state and local emergency management agencies, architects, engineers, academia, district school boards and the American Red Cross (ARC). The task before the advisory committee was to develop criteria that balanced the need to provide a relatively safe and self-sufficient facility, with the need for cost-effective designs and construction methods.

The advisory committee incorporated not only its collective knowledge, experience and existing national codes and standards, but also consulted with Texas Tech and Clemson Universities for severe storm research findings, and with relevant publications, such as the American Red Cross' *Mass Care—Preparedness and Operations* (ARC 3031, superseded by ARC 3041), *Guidelines for Hurricane Evacuation Shelter Selection* (ARC 4496), and the Department of Energy's (DOE) *Standard Natural Phenomena Hazards Design and Evaluation Criteria* (DOE-STD-1020).

The product of this process is a set of comprehensive design criteria that includes structural enhancements, potable water and sanitary requirements, provisions for emergency power, and other considerations that improve survivability and shelter management operations. The promulgation process began in 1994, and was adopted into SREF on April 28, 1997. Subsequently, along with other sections of SREF, the criteria were incorporated in Chapter 423 of the Florida Building Code, which became effective March 1, 2002. This provided a seamless continuation of the criteria for new school construction projects. The public shelter design criteria code provisions in effect at the time of publication of this Plan can be seen in Appendix B.



The public shelter program lessons learned from Hurricane Andrew were further reiterated during the 2004 and 2005 hurricane seasons. During these two seasons alone, approximately 15 million people in Florida were under evacuation orders due to eight (8) hurricanes and two (2) tropical storms. During 2004 and 2005, nearly every county in Florida was under hurricane or inland high wind warnings at some time, prompting mandatory evacuation orders for their coastal storm surge, inland flood vulnerable and manufactured home residents. More than 1,200 shelters were opened, which safely protected about 300,000 evacuees.

In a large-scale emergency, the availability of shelter space is a statewide challenge. Even, if some individual counties have surplus shelter space, deficits in other counties will have statewide implications that will have to be addressed. Evacuees that cannot find shelter space within their own county or region will leave those areas in search of viable shelter alternatives elsewhere. Thus, implementation and enforcement of the public shelter design criteria in new educational facilities is a critical component of Florida's hurricane evacuation shelter space deficit elimination program.

### **1.3 Statutory Considerations**

There are several statutory authorities that are applicable for implementation of the public shelter design criteria. The following statutes have been selected to provide context for decisions relating to planning and exemption of educational facilities.

**252.38 Emergency management powers of political subdivisions.**--Safeguarding the life and property of its citizens is an innate responsibility of the governing body of each political subdivision of the state.

(1) COUNTIES.--

(d) During a declared state or local emergency and upon the request of the director of a local emergency management agency, the district school board or school boards in the affected area shall participate in emergency management by providing facilities and necessary personnel to staff such facilities. Each school board providing transportation assistance in an emergency evacuation shall coordinate the use of its vehicles and personnel with the local emergency management agency.

§252.38, Fla. Stat. provides that "Safeguarding the life and property of its citizens is an innate responsibility of the governing body of each political subdivision of the state." This places the burden for evacuating and sheltering at-risk citizens during an emergency or disaster upon county governing boards (i.e., Board of County Commissioners). To expand and expedite locally available resources to meet an emergency need, the Legislature directed that during a declared state or local emergency, district boards will upon request participate in emergency management by providing facilities, personnel, equipment and vehicles.

District public schools are the primary source of public shelter during tropical weather related emergencies, currently accounting for about 97 percent of statewide hurricane evacuation shelter space. Therefore, it can be presumed that public schools will be used as hurricane evacuation shelters, and often staffed by district personnel. It can also be presumed that public schools will be opened as shelters regardless of the storm's forecasted intensity and track.

Therefore, it is critical that new school facilities be appropriately designed and located to serve the required emergency function.

**252.385 Public shelter space.--**

(1) It is the intent of the Legislature that this state not have a deficit of safe public hurricane evacuation shelter space in any region of the state by 1998 and thereafter.

(2)(a) The division shall administer a program to survey existing schools, universities, community colleges, and other state-owned, municipally owned, and county-owned public buildings and any private facility that the owner, in writing, agrees to provide for use as a public hurricane evacuation shelter to identify those that are appropriately designed and located to serve as such shelters. The owners of the facilities must be given the opportunity to participate in the surveys. The state university board of trustees, district school boards, community college boards of trustees, and the Department of Education are responsible for coordinating and implementing the survey of public schools, universities, and community colleges with the division or the local emergency management agency.

(b) By January 31 of each even-numbered year, the division shall prepare and submit a statewide emergency shelter plan to the Governor and Cabinet for approval, subject to the requirements for approval in s. 1013.37(2). The plan shall identify the general location and square footage of special needs shelters, by regional planning council region, during the next 5 years. The plan shall also include information on the availability of shelters that accept pets. The Department of Health shall assist the division in determining the estimated need for special needs shelter space and the adequacy of facilities to meet the needs of persons with special needs based on information from the registries of persons with special needs and other information.

(4)(a) Public facilities, including schools, postsecondary education facilities, and other facilities owned or leased by the state or local governments, but excluding hospitals, hospice care facilities, assisted living facilities, and nursing homes, which are suitable for use as public hurricane evacuation shelters shall be made available at the request of the local emergency management agencies. The local emergency management agency shall coordinate with these entities to ensure that designated facilities are ready to activate prior to a specific hurricane or disaster. Such agencies shall coordinate with the appropriate school board, university, community college, state agency, or local governing board when requesting the use of such facilities as public hurricane evacuation shelters.

§252.385, Fla. Stat. states the intent of the Legislature to eliminate the deficit of “safe” public hurricane evacuation shelter space. The Division was given both the duty and authority to administer a statewide program to survey public facilities and identify those that are appropriately designed and located to serve as public shelters. To ensure consistency with State and national standards, codes, guidelines and “best practices,” the Division has recognized ARC 4496 as the minimum hurricane evacuation shelter safety criteria. Therefore, at a minimum, meeting ARC 4496 criteria is a required condition for a public facility to be described as “safe,” “suitable” or “appropriate” for recognition as a public hurricane evacuation shelter in this Plan. The public hurricane evacuation shelter capacities listed as “suitable” in this Plan are recognized by the Division as meeting ARC 4496 hurricane safety criteria. See Appendix A.

Appendix A identifies the statewide inventory of facilities recognized as meeting ARC 4496 in their existing condition (i.e., “as-is”), facilities that have been retrofitted to meet ARC 4496, and facilities that have been constructed to meet ARC 4496. New school facilities that are reported by district school boards and local emergency management agencies as having been constructed to the public shelter design criteria are generally recognized by the Division to meet ARC 4496, though storm surge flooding hazards may limit recognition in some cases to exiting storms only.

It should be noted that the Division does not certify, approve or designate hurricane evacuation shelters. Through its survey program, the Division provides data and assistance to local emergency managers, who then use the ARC 4496 criteria as one factor in the selection of shelters. In addition to the ARC 4496 ranking, local emergency managers consider other factors in the selection process, such as, type of event requiring sheltering (known or perceived hazards and risks), location, available staffing resources, internal/external movement circulation, availability of adequate toilets and sanitation, feeding capabilities, standby or emergency electric power, types of spaces available and their configuration and contents, type and condition of roof covering, etc. When anticipated demand exceeds available ARC 4496 shelter space capacity, local emergency managers may select other facilities that afford the best available protection.

With the amendment of §252.385(2)(b), Fla. Stat. in 2006, the Plan is required to include information on the availability of pet-friendly public shelters as well as capacity of SpNS. The Department of Health is required to assist in determining need for SpNS.

As mentioned above, §252.385(4)(a), Fla. Stat. makes available all suitable public facilities owned or leased by state or local government agencies upon request of the applicable local emergency management agency. This broadens the types of facilities that can be used by emergency management officials in a declared emergency, and is consistent with the Division’s authority to survey all appropriate public facilities for use as public hurricane evacuation shelters.

**1013.372 Education facilities as emergency shelters.—**

(1) The Department of Education shall, in consultation with boards and county and state emergency management offices, include within the standards to be developed under this subsection public shelter design criteria to be incorporated into the Florida Building Code. The new criteria must be designed to ensure that appropriate new educational facilities can serve as public shelters for emergency management purposes. A facility, or an appropriate area within a facility, for which a design contract is entered into after the effective date of the inclusion of the public shelter criteria in the code must be built in compliance with the amended code unless the facility or a part of it is exempted from using the new shelter criteria due to its location, size, or other characteristics by the applicable board with the concurrence of the applicable local emergency management agency or the Division of Emergency Management. Any educational facility located or proposed to be located in an identified category 1, 2, or 3 evacuation zone is not subject to the requirements of this subsection. If the regional planning council region in which the county is located does not have a hurricane evacuation shelter deficit, as determined by the Division of Emergency Management, educational facilities within the planning council region are not required to incorporate the public shelter criteria.

As directed by law, the Department of Education was required to develop criteria, in consultation with district boards and state and local emergency management offices, to ensure that appropriate new educational facilities can serve as public shelters for emergency management purposes. The criteria are required to be incorporated into the Florida Building Code (i.e., s. 423.25, *Florida Building Code--Building*), and all new facilities for which a design contract is entered into after incorporation of the criteria into the code must be built in compliance with the criteria. The public shelter design criteria are applicable to both district school board and community college facilities, and became effective on April 28, 1997. These criteria were also codified into the *Florida Building Code--Building* on March 1, 2002.

§1013.372(1), Fla. Stat. allows a board to exempt a facility from the criteria if the location, size or other characteristics is inappropriate for use as a public shelter. A facility that is located, or proposed to be located, in a Regional Planning Council region that is determined by the Division to have a hurricane evacuation shelter surplus may also be exempted. **It is unlawful and a violation of the Florida Building Code for a board to exempt a new educational facility from the criteria without the written concurrence of the applicable local emergency management agency or the Division.**

**1013.74 University authorization for fixed capital outlay projects.—**

(4) The university board of trustees shall, in consultation with local and state emergency management agencies, assess existing facilities to identify the extent to which each campus has public hurricane evacuation shelter space. The board shall submit to the Governor and the Legislature by August 1 of each year a 5-year capital improvements program that identifies new or retrofitted facilities that will incorporate enhanced hurricane resistance standards and that can be used as public hurricane evacuation shelters. Enhanced hurricane resistance standards include fixed passive protection for window and door applications to provide mitigation protection, security protection with egress, and energy efficiencies that meet standards required in the 130-mile-per-hour wind zone areas. The board must also submit proposed facility retrofit projects to the Division of Emergency Management for assessment and inclusion in the annual report prepared in accordance with s. 252.385(3). Until a regional planning council region in which a campus is located has sufficient public hurricane evacuation shelter space, any campus building for which a design contract is entered into subsequent to July 1, 2001, and which has been identified by the board, with the concurrence of the local emergency management agency or the Division of Emergency Management, to be appropriate for use as a public hurricane evacuation shelter, must be constructed in accordance with public shelter standards.

§1013.74(4), Fla. Stat., provide state university boards of trustees statutory duties similar as those of district public schools and community colleges. State universities, in consultation with state and local emergency management agencies, are directed to assess existing facilities to identify the extent to which each campus has public hurricane evacuation shelter space.

Each campus is then responsible for developing a five-year capital improvements program that identifies potential new and retrofitted facilities that can be used as public hurricane evacuation shelters. The statute indicates that the facilities will incorporate “enhanced hurricane resistance standards” and must be constructed in accordance with “public shelter standards,” but does not specify the Florida Building Code’s public shelter design criteria. The Division recommends use of the Florida Building Code’s public shelter design criteria for university



facilities that are appropriate for use as public shelters. All campus buildings for which a design contract is entered into after July 1, 2001 are required to be constructed to the standard.

The statute indicates that a university board of trustees may exempt a facility from the criteria with the concurrence of the applicable local emergency management agency or the Division. A facility that is proposed to be located in a Regional Planning Council region that is determined by the Division to have a hurricane evacuation shelter surplus may also be exempted. As with district school boards and community colleges, **it is unlawful for a university board of trustees to exempt a new campus facility from the criteria without the written concurrence of the applicable local emergency management agency or the Division.**

**381.0303 Special Needs Shelters. --**

(2)(d) Local emergency management agencies shall be responsible for the designation and operation of special needs shelters during times of emergency or disaster and the closure of the facilities following an emergency or disaster. The local health department and emergency management agency shall coordinate these efforts to ensure the appropriate designation and operation of special needs shelters. County health departments shall assist the local emergency management agency with regard to the management of medical services in special needs shelters.

§381.0303(2)(d), Fla. Stat. requires local emergency management agencies to designate public SpNS. The Department of Health (through County Health Departments) is assigned the duty to assist with managing the medical service needs of the clients.

The Division strongly recommends that as with general population public hurricane evacuation shelters, public SpNS hurricane evacuation shelters designated by local emergency management agencies should meet the ARC 4496 hurricane safety criteria, and preferably designed and constructed to the public shelter design criteria.

## 2.0 EDUCATIONAL FACILITIES AS EMERGENCY SHELTERS

The public shelter design criteria, which are also known as Enhanced Hurricane Protection Area (EHPA) criteria, were designed to ensure that appropriate new educational facilities can serve as public shelters for emergency management purposes. The EHPA criteria can be found in Section 423.25, *Florida Building Code—Building*. Public educational facilities primarily serve an educational purpose. During a declared state of emergency these facilities may function as public shelters. The public shelter function is a lawfully authorized function, and during a declared state or local emergency can preempt normal educational functions. Therefore, consideration of the emergency management purpose is a critical component of the design of a new educational facility. The following sections will provide consultative (or advisory) guidance for implementing the criteria.

### 2.1 Public Shelter Design Criteria

The EHPA criteria ensure that new educational facilities meet or exceed applicable national design and construction standards, guidelines and “best practices.” The EHPA criteria have been designed to significantly enhance occupant safety and building integrity. One of the main objectives of the EHPA is to ensure that these facilities continue to serve the public after exposure to a major hurricane.

It is highly recommended that prior to design that the facility owners, planners and designers incorporate the American Red Cross’ ARC 4496 in the planning process for an EHPA. See Appendix C. ARC 4496 is the minimum hurricane evacuation shelter safety guideline used by the Division, American Red Cross and local emergency management officials for surveying and ranking public hurricane evacuation shelters. ARC 4496 can also be viewed at the following web address:

<http://www.floridadisaster.org/Response/engineers/documents/newarc4496.pdf>

ARC 4496 requires that public hurricane evacuation shelters be designed, constructed and capable of withstanding wind loads according to the American Society of Civil Engineers Standard 7 (ASCE 7). The EHPA code provisions recommend increasing the design map wind speed by 40 miles per hour. The Division endorses this recommendation.

Please review Appendix G for additional advisory guidance on design criteria, including wind and debris impact resistance, foundation and floor slab elevation, location and site requirements, shelter occupant capacity, plumbing and sanitation, electrical standby and emergency power systems, and emergency management considerations. There are other useful resources to be considered in the EHPA design process, such as: 1) International Code Council’s *Standard on the Design and Construction of Storm Shelters* (ICC 500), 2) the Department of Energy’s (DOE) *Standard Natural Phenomena Hazards Design and Evaluation Criteria* (DOE-STD-1020), and 3) the Federal Emergency Management Agency’s (FEMA) publication *Design and Construction Guidance for Community Safe Rooms* (FEMA 361).

SpNS should meet the same hurricane safety criteria as general population shelters (ARC 4496 and other state and national public shelter criteria). Following the 2004 hurricane season, ,

Division and the Department of Health, in consultation with the Executive Office of the Governor, issued a memorandum stating an expectation that SpNS be located in facilities that at a minimum meet the ARC 4496 hurricane safety criteria, that SpNS client occupied areas have standby power supported air-conditioning, and that client shelter spaces be based on 60 square feet per client (20 square feet is used for general population shelter spaces). The 60 square feet of spaces includes an allowance for care-givers and medical equipment. For further guidance, please see the following memorandum dated June 6, 2005:

<http://www.floridadisaster.org/documents/Agwunobi-Fugate%20SpNS%206-7-2005.pdf>

## **2.2 Exemption Criteria**

All new educational facilities must be designed and constructed to comply with the EHPA criteria unless specifically exempted by the board, with the written concurrence of the applicable local emergency management agency or the Division. See §1013.372, Fla. Stat.

**It is unlawful and a violation of the Florida Building Code for a board to exempt a new educational facility from the criteria without the written concurrence of the applicable local emergency management agency or the Division.**

The fact that the EHPA criteria may increase the cost of construction of a facility, by itself, is not a factor that will be considered for an exemption by the Division. Cost of construction may only be considered as one of a number of factors when selecting which new facilities are to be designed and constructed to meet the EHPA criteria. Selection may be based upon cost-effectiveness, greatest provision of shelter space, and other factors that enhance shelter usefulness.

The EHPA requirement applies to any building construction project that is “new construction,” as defined in §1013.01(14), Fla. Stat. and s. 423.5.8, *Florida Building Code—Building*. That is, any construction of a building or unit of a building in which the entire work is new, or an entirely new addition connected to an existing building. This includes replacement buildings and new buildings and additions constructed on existing campuses. The EHPA requirement also applies to reuse and prototype plans, since they are required to be code updated with each new project.

The EHPA requirement is not limited to rooms or spaces defined as “core facilities” in §1013.01(5), Fla. Stat. The statutory definition is intended for educational facilities purposes, and defines “core facilities” to be media centers, cafeterias, toilet facilities and circulation space (e.g., corridors, lobbies, etc.) §1013.372(1), Fla.Stat. states that “A facility, or an appropriate area within a facility...must be built in compliance with the (EHPA criteria) unless the facility or a part of it is exempted...” The statute does not limit EHPA’s to “core facilities,” but permits use of an entire facility, or appropriate areas within a facility.

Both the Florida Statutes and the Florida Building Code provide factors to consider in exempting an educational facility from complying with the criteria. ARC 4496 may also provide supplemental guidance to consider in the exemption process. The following subsections provide advisory guidance when considering an exemption request.

### 2.2.1 Location.

In general, there are five factors to be considered when making an exemption request due to location: 1) location of the proposed EHPA site within an identified Category 1, 2 or 3 hurricane evacuation zone; 2) location subject to hurricane-related rainfall or storm surge flooding or isolation; 3) location on a coastal barrier island; 4) location within the evacuation zone of facilities that manufacture, use or store certain types and quantities of hazardous materials; and 5) low evacuation demand.

**Category 1, 2 or 3 Evacuation Zone.** New educational facilities located or proposed to be located in an identified Category 1, 2 or 3 hurricane evacuation zone are exempt from the EHPA criteria. “Hurricane Evacuation Zones” are areas designated to be evacuated for particular hurricane scenarios to protect an at-risk population from flooding. Evacuation zones are developed taking into consideration all populated areas having a serious risk of flooding, areas not subject to flooding but may be cut-off or completely surrounded or isolated by flooded areas, and the need to be easily communicated to the public.

Hurricane evacuation zones are applicable to coastal counties, and possibly counties adjacent to Lake Okeechobee. Hurricane evacuation zones include areas that are subject to storm surge inundation, as predicted by the National Weather Service’s Sea, Lake and Overland Surges from Hurricanes (SLOSH) model. Category 1, 2 and 3 evacuation zones are subject to evacuation during land-falling major hurricanes, as well as paralleling and exiting major hurricanes.

Category 4 and 5 hurricanes are relatively uncommon events, and based upon the storm track heading with respect to coastline (i.e., land-falling, paralleling or exiting), Category 4/5 hurricane evacuation zones may not be inundated by storm surge. Therefore, new educational facilities proposed to be located in Category 4/5 evacuation zones are not statutorily exempt from the EHPA criteria.

Also, to facilitate communication of evacuation orders to the public during an emergency, hurricane evacuation zones are normally established using geographic, jurisdictional or transportation/utility boundaries and landmarks that are known and readily identified by the local population. Therefore, hurricane evacuation zone boundaries may extend further inland than the SLOSH model’s predicted inundation areas. New educational facilities proposed to be located in a Category 4 or 5 evacuation zone may in fact be outside of the SLOSH predicted inundation areas. EHPA’s located in Category 4 or 5 evacuation zones may provide emergency managers with additional sheltering options.

The 2010 Statewide Regional Evacuation Studies (SRES) introduce alphabetic Evacuation Zones (A-E) across the State. For planning purposes, the reference to areas to be evacuated from a Category 1 hurricane is Evacuation Zone A, reference to areas to be evacuated in advance of a Category 2 hurricane is Evacuation Zone B, and reference to areas to be evacuated from a Category 3 hurricane is Evacuation Zone C. Similarly, references to evacuation areas from Category 4 or 5 hurricanes are Evacuation Zones D or E respectively.



Category 4/5-related exemption decisions will be dependent upon the magnitude of the county and regional hurricane evacuation shelter space deficit, local logistical support capabilities and the availability of suitable alternatives (either in-place, or within the framework of a five-year plan.)

**Rainfall or storm surge flooding or isolation.** New educational facilities proposed to be located in areas subject to flooding or isolation due to rainfall or storm surge related flooding may be inappropriate for use as public hurricane evacuation shelters. Rainfall flooding includes closed-basin ponding, riverine and containment failure of dams and reservoirs. Extended-periods of isolation of a shelter population presents logistical challenges for emergency managers and mass care support agencies, which normally prefer equally suitable buildings not subject to flooding or isolation. The challenges include staff rotation, resupply of food, water and other consumables, emergency medical assistance, sanitation, security concerns, communication, etc. Flooding and isolation-related exemption decisions will be dependent upon the magnitude of the county and regional hurricane evacuation shelter space deficit, design and construction standards of the facility, shelter floor elevation, local logistical support capabilities and the availability of appropriate alternatives (either in-place, or within the framework of a five-year plan.)

**Coastal Barrier Island.** Coastal barrier islands are often less than two (2) miles wide with very low ground elevations above mean sea level (AMSL). As such, they are exceptionally at-risk to storm surge inundation, isolation, and exposure to the full force of hurricane winds. Also, ARC 4496 states that hurricane evacuation shelters must not be located on barrier islands. Therefore, facilities on coastal barrier islands are often subject to an exemption from the EHPA criteria. Coastal barrier island exemption decisions will be dependent upon the magnitude of the county and regional hurricane evacuation shelter space deficit, shelter floor elevation, local logistical support capabilities and the availability of appropriate alternatives (either in-place, or within the framework of a five-year plan.) The Division uses §161.54(2), Fla. Stat., to provide a definition for coastal barrier islands.

**Hazardous Materials.** Location of a proposed new educational facility within the Vulnerability Zone (VZ) of facilities that manufacture, use or store certain types and quantities of hazardous materials may make it unsuitable for use as public hurricane evacuation shelter. Just as with flooding isolation concerns, the possible impact of a hazardous materials spill or release presents public safety and logistical challenges to emergency managers and mass care support agencies. In addition to the challenges listed for flooding isolation, hazardous materials emergencies include detecting and warning of presence of a hazard, and implementing shelter-in-place or evacuation actions. However, most facilities with reportable quantities of hazardous materials are considered a low risk of hurricane-related spill or release due to presence of mitigation measures (e.g., limited quantities of materials, hardening of containment structures, etc.)

Hazardous materials-related exemption decisions will be dependent upon the potential for and probable impact of a hurricane-related spill or release, potential hurricane evacuation shelter's distance from hazardous materials facility, guidance from Local Emergency Planning Committee (LEPC) and local fire department, magnitude of the county and regional hurricane

evacuation shelter space deficit, detection and warning capabilities, local logistical support capabilities and the availability of appropriate alternatives (either in-place, or within the framework of a five-year plan.)

It should be noted that many educational facilities use or store hazardous materials that are used for janitorial services and maintenance, vocational or laboratory uses, refrigeration, water treatment, etc. Such materials are normally very limited in quantity, and suitably stored or protected, and therefore rarely a significant consideration for an exemption. The Division recommends consultation with the applicable LEPC and local fire department to determine appropriate precautionary measures.

**Low Evacuation Demand.** New educational facilities proposed to be located in areas with low evacuation demand may be considered for an EHPA exemption. Emergency managers and other mass care providers prefer to locate hurricane evacuation shelters in close proximity to the evacuees they will serve. Therefore, the emergency management agency may reduce the EHPA floor area square footage requirement to meet local evacuation demand needs, or possibly exempt the entire facility if a suitable alternative is available. Low evacuation demand exemption decisions will be dependent upon the magnitude of the county and regional hurricane evacuation shelter space deficit, local shelter demand needs and the availability of appropriate alternatives (either in-place, or within the framework of a five-year plan.)

### 2.2.2 Size.

The required size of a hurricane evacuation shelter is very dependent upon local circumstances. To effectively utilize available resources and operational plans (e.g., staffing, feeding, security, etc.), a hurricane evacuation shelter located in an area with low evacuation demand can be significantly smaller than a facility located near a highly populated hurricane evacuation zone. Public hurricane evacuation shelters can range from as small as about 50 spaces to as large as several thousand spaces.

§252.385(4)(b), Fla. Stat. can serve as a guide when establishing a minimum size criterion for public hurricane evacuation shelters. This statute applies to suitable Department of Management Services owned or leased facilities, and requires that the facility have a minimum of 2,000 square feet of net floor area. The required minimum net floor area can be in a single room, or a combination of rooms each having a minimum of 400 square feet of net floor area. At 20 square feet per shelter space, this translates into a minimum capacity of about 100 spaces.

Therefore, to be consistent with §252.385(4)(b), Fla. Stat., the Division generally considers new educational facilities with less than 2,000 square feet of net usable floor area to be small enough for an exemption.

### **2.2.3 Other Considerations.**

“Other Considerations” is interpreted to mean any factor that is determined to make the facility inappropriate for use as a public hurricane evacuation shelter. This will generally be related to incompatibility of a facility’s normal function or availability with public shelter operations.

As examples, the following types of spaces are normally excluded during calculation of net usable occupant capacity of a hurricane evacuation shelter, and are therefore often avoided by emergency managers when selecting shelters:

Mechanical, plumbing, electrical, telephone and communication equipment rooms, storage rooms and closets, exterior/outside circulation and corridors, restrooms and shower areas, kitchen and food preparation rooms, science labs, computer and information technology labs, vocational and industrial technology labs and shops, library and media rooms, exercise rooms with fixed equipment, administrative office and support areas, data and word processing rooms and areas, record vaults, mail rooms, custodial rooms and work areas, medical clinic and first aid rooms, residential and dormitory rooms, radio or television broadcast facilities, attics and crawl spaces, etc.

New educational facilities that are designed exclusively to serve these functions may be exempted from complying with the EHPA criteria.

Other considerations may also include local strategies and long-range plans. As an example, to reduce costs and maximize hurricane evacuation shelter usefulness, a board and local emergency management agency may agree (in writing) that 100 percent of the floor area of new high schools will be constructed to the EHPA criteria, instead of the minimum of 50 percent, in exchange for reducing or eliminating EHPA requirements for middle and elementary schools. The proposed plan eliminates the county hurricane evacuation shelter space deficit, plus creates additional space toward reducing the regional deficit, within about five years. Thus the long-range plan achieves statutory intent, and exemptions for applicable middle and elementary schools are acceptable.

### **2.2.4 Alterations, Maintenance or Repair of Existing Buildings.**

Florida Statutes and the Florida Building Code both state that the EHPA criteria apply to “new educational facilities.” Therefore, renovations, remodeling, maintenance and repair of existing buildings, as defined in §1013.01, Fla.Stat. and s. 423.5, *Florida Building Code--Building*, are exempt from compliance with the EHPA criteria.

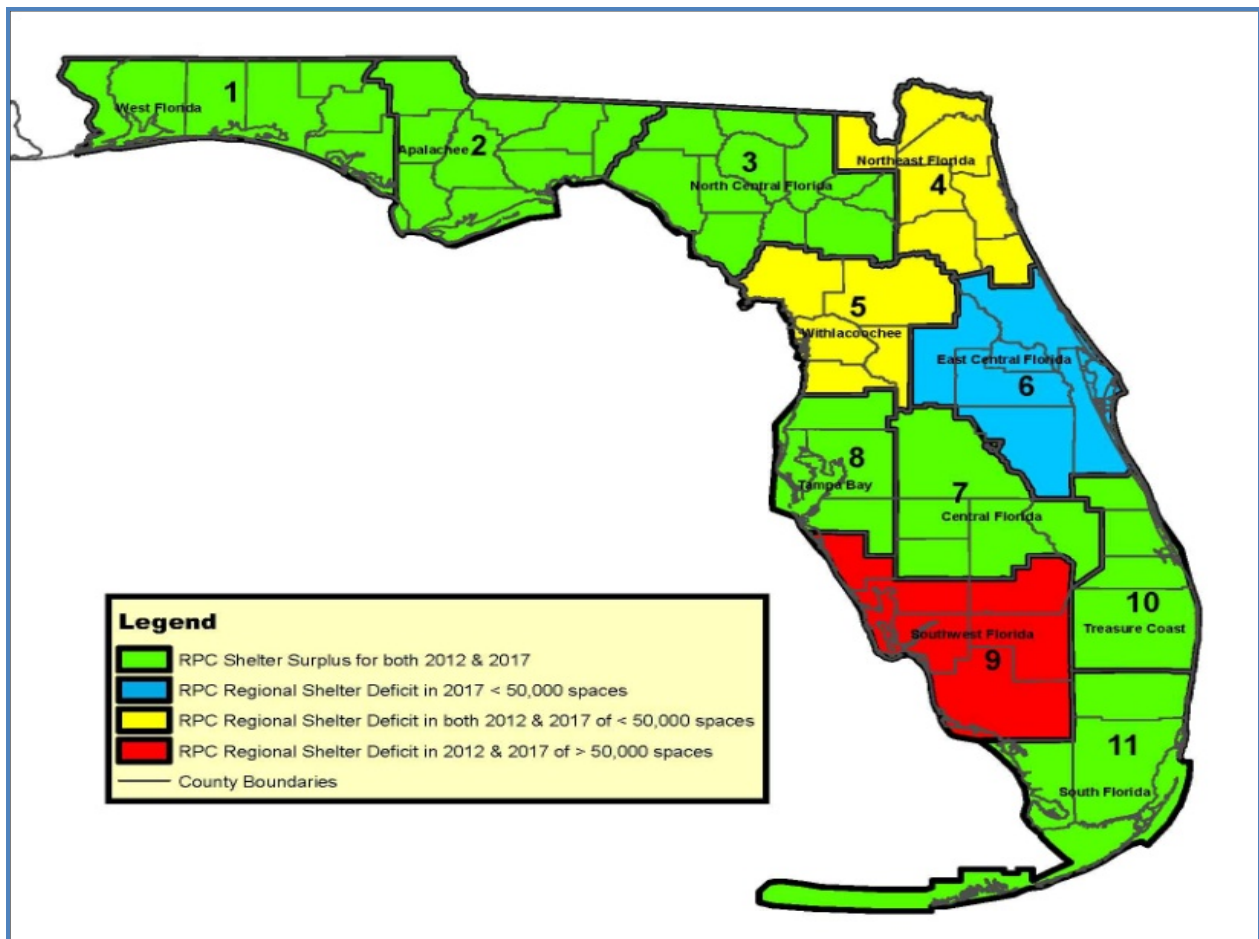
### **2.2.5 Regional Surplus of “Safe” Hurricane Evacuation Shelter Space.**

§1013.372, Fla. Stat. states that new educational facilities proposed to be located in a Regional Planning Council (RPC) region that does not have a hurricane evacuation shelter space deficit are not required to incorporate the EHPA criteria. The hurricane evacuation shelter surplus/deficit determination is established by biennial publication and approval of this Plan, which guides exemption decisions over a five year planning period

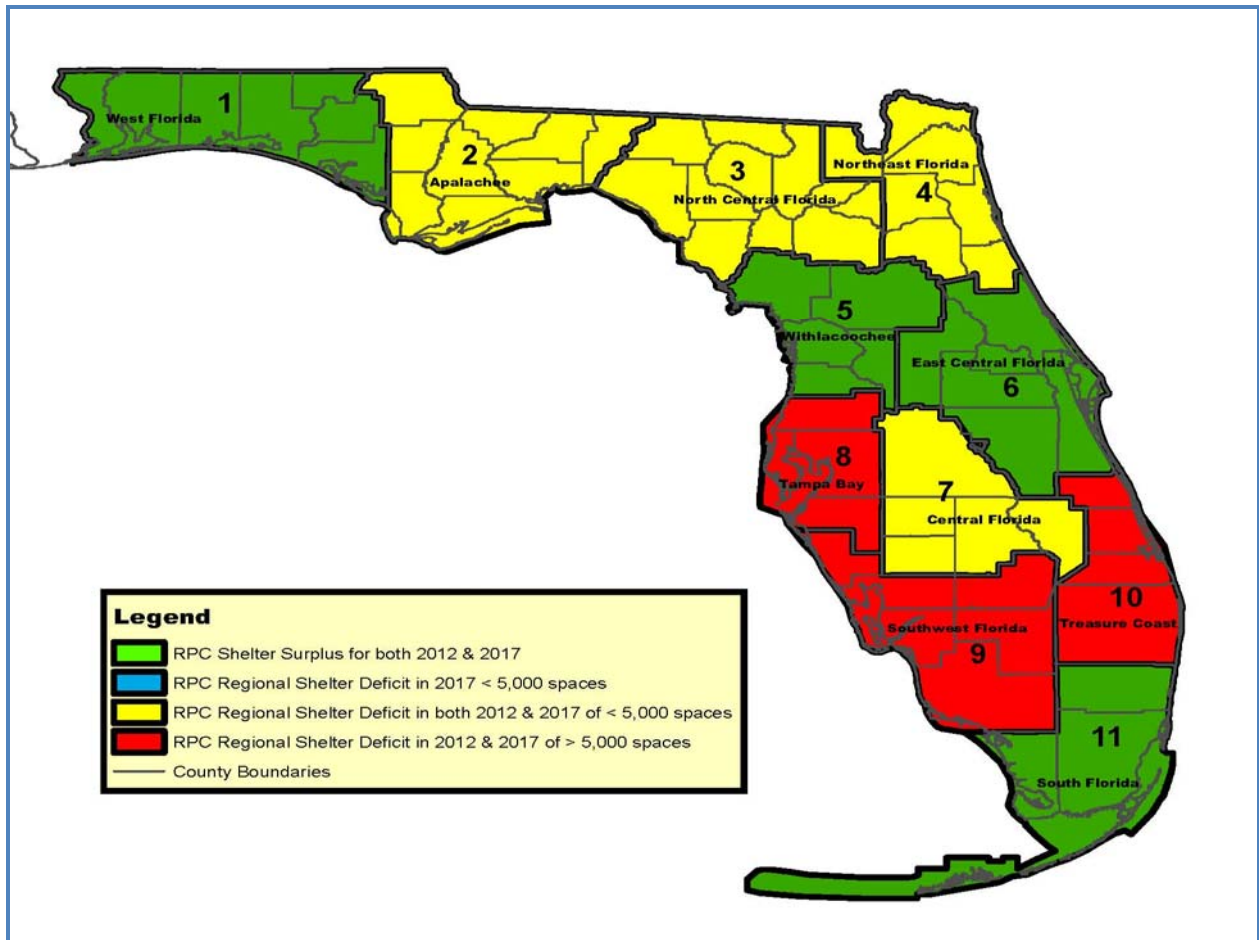
As can be seen in Figure 2-1, eight (8) RPC regions have a surplus of general population hurricane evacuation shelter space in 2012, which includes RPC regions 1, 2, 3, 6, 7, 8, 10, and 11. Based upon currently available information, surpluses will continue in RPC regions 1, 2, 3, 7, 8, 10, and 11 through 2017. RPC region 6 could return to a deficit if no additional hurricane evacuation shelter spaces are added to the inventory. However, as can be seen in Figure 2-2 there is a surplus of SpNS spaces in only four (4) regions, to include regions 1, 5, 6 and 11. The SpNS space deficits are projected to continue into 2017 if no new space is added to the inventory.

With the exception of two (2) regions (regions 1 and 11), all other regions have hurricane evacuation shelter space deficits in either general population, SpNS or both shelter types. Therefore, per §1013.372(1) and §1013.74(4), Fla. Stat. their respective district school boards, community colleges and universities are required to construct new educational facilities in compliance with the public shelter design criteria.

**Figure 2-1. Regional Hurricane Evacuation Shelter Space Surplus/Deficit Status of General Population Shelters**



**Figure 2-2. Regional Hurricane Evacuation Shelter Space Surplus/Deficit Status of Special Needs Shelters**



### 2.3 **Exemption Process**

In accordance with §1013.372, Fla. Stat. and s. 423.25, *Florida Building Code--Building*, the following procedure is recommended by the Division when requesting exemptions from the public shelter design criteria/EHPA requirement:

1. The board must notify the local emergency management agency of all educational facility construction projects that meet the definition of new construction.
2. The board must evaluate each new educational facility construction project to determine if a statutory or code specified exemption to the criteria is applicable.
3. If an exemption is not requested, the board should consult with the local emergency management agency to identify those areas of the new facilities that will maximize public shelter capacity, and meet the needs of both the educational and emergency management purpose.
4. If the board requests an exemption, the request must be prepared and submitted in writing to either the local emergency management agency or the Division. The request must identify the specific statutory or code factor(s) to be considered for the exemption, and provide appropriate supporting documentation.
5. If the local emergency management agency or the Division concurs with the exemption request, a written response stating the concurrence will exempt the new educational facility from the criteria.
6. If the local emergency management agency or the Division does not concur in writing with the exemption request, then the board must comply with the criteria.

#### 2.4 **Estimate of School District Compliance with EHPA Requirements (2010-2011)**

In 2001, staff from the Auditor General's Office performed a hurricane shelter and grant management operational audit of the Department of Community Affairs. See Auditor General Report No. 02-055, dated October, 2001. In Finding No. 2 of the report, the Auditor General found that a significant number of new educational facilities, constructed by district school boards and community colleges, had not complied with the public shelter design criteria, and had not received an exemption (written) by local emergency management agencies or the Division. Given the projected deficits of public hurricane shelter space in this state, the Auditor General indicated that steps must be taken to remedy the situation.

The Auditor General recommended that the Division, in consultation with the State Legislature, Florida Department of Education and local emergency management officials, continue its efforts to ensure compliance with the provisions of the law. Subsequently, the Department of Education distributed memorandum number DPBM No. 02-42 (from Wayne V. Pierson, dated October 31, 2001) that reiterated the necessity for compliance with the statute. A copy of memorandum DPBM No. 02-42 is included in Appendix I.

Since distribution of the Auditor General's report and the Department of Education's memorandum in 2001, the Division has taken additional steps to encourage compliance with the EHPA criteria through the emergency management community. In 2003, with the assistance of the Department of Education, the Division compiled a list of new school facilities from the Florida Inventory of School Houses (FISH) with construction years between 2000 and 2003. Unless exempted, these school facilities were lawfully required to incorporate the EHPA criteria. The lists were forwarded to local emergency managers to assist them in determining local compliance, as well as assist in identifying additional unreported shelter capacity.

The Division also annually requests hurricane shelter capacity data from local emergency management agencies that is sorted to differentiate new school EHPA's, retrofit, and "as-is" (i.e., ARC 4496 hurricane shelter facilities that are not classified as a retrofit or EHPA) shelter space. This data is used to monitor progress toward eliminating county-level, regional and statewide hurricane shelter space deficits. The data also provides a means of tracking EHPA productivity on an annual basis.

The Division substantially revised the 2004 Plan to incorporate guidance to assist local school boards and emergency managers with implementing the criteria. The Division and Department of Education also participated in presentations and workshops at conferences that included the topic of EHPA construction requirements, code compliance and implementation strategies. The conferences were attended by emergency managers and their shelter program partners, school board officials, code enforcement officials, architects and engineers (e.g., National Hurricane Conference, Governor's Hurricane Conference, Florida Emergency Preparedness Association Meetings, etc.)

From 2000 through 2009 the Division observed similar results to those of Auditor General staff in 2000. Therefore, the 2004 through 2010 Plans reported a cumulative average of about 65 percent compliance.

In preparation for the 2012 Plan, the Division again collaborated with the Department of Education to compile a list of new school buildings from the FISH data. However, for the 2012 Plan, the list of new buildings was limited to those constructed in years 2010 and 2011 with at least 4,000 net square feet. Universities and community colleges were not included primarily due to the fact that they only account for about two (2) percent of the statewide shelter space inventory. The data was then used in coordination with local emergency managers to estimate compliance by school boards with the EHPA requirement for years 2010 and 2011.

The FISH data was analyzed to determine which facilities were located in Category 1, 2 or 3 storm surge evacuation zones, and those that had relatively little usable floor area (i.e., less than 2,000 square feet of net usable space). These characteristics provide a cause for an exemption. The Division also incorporated data from the facilities that were previously recognized as meeting EHPA criteria. The data was then tabulated and distributed to local emergency managers. The Division requested that local emergency managers verify which facilities are recognized as EHPA's, and which facilities (if any) received exemptions from their office. The Division has not granted an exemption, so any exemptions would have been local. Table 2-1 provides a summary of the findings.

According to FISH data, there were 60 new school buildings (based on at least 4,000 net square feet of area per room types listed in Appendix H) constructed between 2010 and 2011, with an estimated total net floor area of 1,414,586 square feet. The Division recognizes 26 facilities (640,884 net square feet) as meeting the EHPA requirements of the law, and another 29 buildings (692,790 square feet) were lawfully exempt for statutory and code provided causes. Therefore, 55 of 60 new buildings complied with statutory and code EHPA requirements.

Since the EHPA code requirements are based on achieving a minimum quantity of floor area square footage, the square footage is the most reliable means of estimating compliance. The combined floor area square footage of the non-compliant buildings is 80,912 square feet, or a non-compliance rate of six (6) percent. The result of the survey indicates that compliance rate, statewide, has improved. The Division will continue to coordinate with the Department of Education and local emergency managers to monitor and improve compliance.



**Table 2-1. Estimate of Local Compliance with EHPA Requirements  
for Years 2010 and 2011**

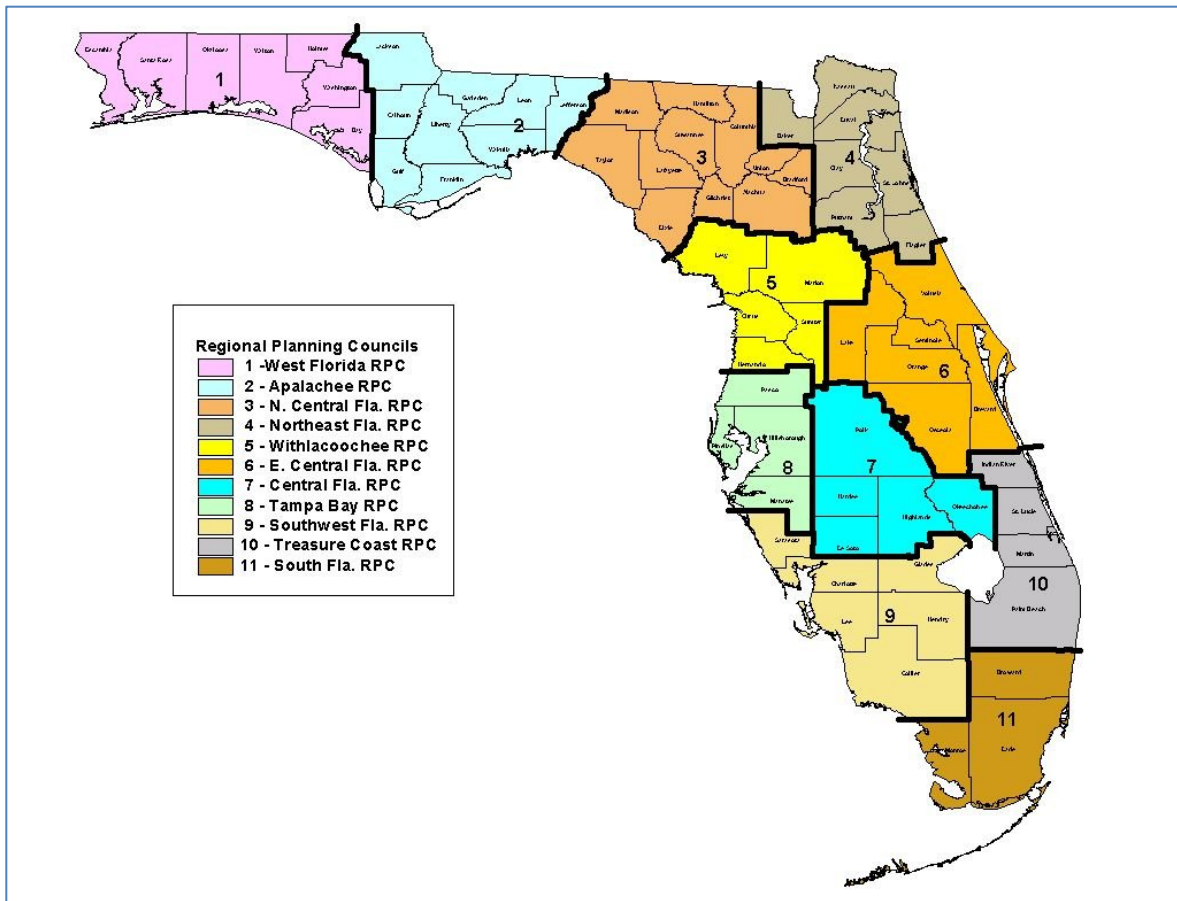
<b>Description</b>	<b>Number of Buildings</b>	<b>Net Square Feet</b>
Total Number of New Buildings	60	1,414,586
Division Recognized EHPA Buildings	26	640,884
Total Number of New Buildings exempted per Code	29	692,790
Total Number of New Buildings that met Lawful Requirements	55	1,333,674
Total Number of New Buildings that did not meet Lawful Requirements	5	80,912
Potential EHPA Space Lost (50% required by Code)	---	80,912
Potential EHPA Net Square Feet Lost (usable NSF after application of usability factors)	---	40,456
Potential EHPA Spaces Lost (at Code required 20 square feet each)	---	2,022 spaces
<b>Description</b>	<b>Percent of Buildings</b>	<b>Percent of Net Square Feet</b>
Percentage of New Buildings that Complied with the Law	92	94
Percentage of New Buildings that did not Comply with the Law	8	6

### 3.0 REGIONAL HURRICANE EVACUATION SHELTER REQUIREMENTS

The State of Florida underwent a comprehensive Statewide Regional Evacuation Study (SRES) which was completed in late 2010. This study includes an update of SLOSH modeling and storm surge zones for all of Florida’s basins (to include Light Detection and Ranging (LiDAR) data of the state’s entire coastline), a statewide evacuation Behavioral Study, and development of a statewide Shelter Analysis and Transportation modeling tool. The data from the 2010 SRES is the projected 2012 and 2017 data used for the 2012 Plan. The overall projected population in the 2010 SRES was 19,979,199. The 2010 Census indicated Florida’s total population was 18,801,310. Since the 2010 SRES projections were slightly higher than the 2010 census, and these numbers were published after the 2010 Plan, it was determined that this data should be used to estimate the shelter demand for the 2012 Plan.

The SRES regions are RPC regions. The RPC regions and their respective counties are shown in Figure 3-1 for illustration purposes.

**Figure 3-1. Regional Planning Council (RPC) Regions of Florida**



### **3.1 Methodology for Calculating Regional and County Hurricane Evacuation Shelter Status**

**Location and Square Footage of Existing Shelters.** The location and square footage of existing shelters can be found in Appendix A, which provides a detailed inventory of hurricane evacuation shelter locations and capacities within each region and county. The tables in Appendix A use the term “risk” shelters. Risk shelters include those shelter spaces recognized by the Division as meeting ARC 4496 hurricane safety guidelines and identified as appropriate for use during a hurricane impact. The term “risk” shelter is further defined in Appendix E.

**Location and Square Footage of Needed Shelters.** Region/County estimates for Shelter Capacity, Shelter Demands, and Shelter Surpluses/Deficits are provided in Table 3-1 and are based on Saffir-Simpson Hurricane Intensity Category 5 (Category 5) evacuation worst case scenario. Results contained in Table 3-1 for 2012 and 2017 are displayed in number of persons. Region/County square feet estimates for 2012 and 2017, using the same Category 5 worst case scenario, are provided in Table 3-2.

**Shelter Demand Sources/Results by County.** The 2012 through 2017 county shelter demand estimates for vulnerable populations are provided for Category 5. Vulnerable populations are defined as populations located in storm surge vulnerable areas (coastal and inland lake or river), rainfall flood prone areas and those living in mobile or manufactured housing. Source data for these estimates, including demographics, estimated percent vulnerable populations, estimated percent of vulnerable populations expected to seek public shelter, and other sources are shown in Appendix J.

The 2012 through 2017 population estimates are based on the information contained in the 2010 SRES. The vulnerable populations and the percentage expected to seek shelter were also derived from 2010 SRES. The Statewide Regional Evacuation Studies used the following guiding principles for the demographic analysis:

1. The best available data should be used for creating housing unit counts and population estimates, housing unit and population projections, and demographic profiles.
2. All regional studies should use the April 1, 2006 of University of Florida’s Bureau of Economic and Business Research (BEBR) baseline for housing unit and population estimates, with April 1, 2010 (2012 Plan) and April 1, 2015 (2017 Plan) projections for comparison.
3. Demographics estimates for both counties and small areas for the baseline and the projections for 2010 (2012 Plan) and 2015 (2017 Plan) should be consistent with “official” county-level totals (current state estimates and projections from the University of Florida’s BEBR or adopted comprehensive plans with methodology approved by the Florida Department of Community Affairs).

**Determining County Shelter Capacities.** County shelter capacity data for all 67 counties were updated by local emergency management agencies through 2011. Since 1995, Florida has been implementing ARC 4496 hurricane evacuation shelter criteria and Florida's *Model Hurricane Evacuation Shelter Selection Guidelines*. Therefore, based upon subsequent results of regional and county hurricane evacuation shelter surveys, local emergency management agencies were requested to provide shelter inventory capacities based on those facilities that met the required ARC 4496 standards, and separately those facilities that did not.

Those facilities that have not yet been surveyed, and therefore have not yet been documented to meet the above standards, were designated as facilities not meeting the ARC 4496 standards. The Division has standardized a consistent methodology of calculating shelter capacities across the state for the purpose of this Plan. For each shelter, a net square footage for the building was derived from the Florida Department of Education's FISH database, including only those room types listed in Appendix H of this Plan. See Appendix H. Then, each room's square footage was multiplied by a usability factor based on room type. This generated a "dormitory" or square footage area that is usable as clear shelter space. This figure was then divided by 20 square feet per person for general population risk shelters and 60 square feet per client for special needs risk shelters. These are the square footages and capacities used to calculate the Hurricane evacuation shelter deficit reduction in this Plan.

The Division recognizes that many counties have local preferences and practices that may further limit usage of buildings. For example, one county may choose to utilize only hallways, gyms or cafeterias, even though the rest of the building (i.e. classrooms) also meets ARC 4496 guidelines. In some cases, the limiting factor is the number of available staff, i.e., they can staff for only 500 people in a given location, even though they have space for many more. Also the local shelter capacity at a specific building may exceed local need. In recognition of these and other variances, the Division has included a column titled "Local Planned Usage" in the individual county tables in Appendix A. However, it should be noted that the capacities calculated per the method in the paragraph above, still exist and could, in an emergency, be utilized and therefore are counted toward elimination of the regional and county hurricane evacuation shelter space deficit.

**Determining County Shelter Demand.** The hurricane evacuation shelter demand percentage for each county reflects the percentage of a county's vulnerable population that is projected to seek public shelter. These percentages are based on the conclusions of the behavioral analyses conducted for each of the regional evacuation studies. The analyses utilize survey and statistical methodologies to estimate behavioral responses to various hurricane scenarios. It is important to note that results obtained by a survey do NOT always correlate to actual behavior. What people say they will do during a "blue sky" survey often differs from actual behavior, which is influenced by a number of factors. Strength of storm, time since most recent significant disaster, and previous experience (or lack of) with tropical weather are just a few factors that influence a person's decision to evacuate or seek shelter. Hence, shelter demand may fluctuate over

time. All estimates are based on a worst case storm scenario and optimal compliance with local evacuation orders.

Most of the behavioral analyses in the state have been prepared on a regional basis by Hazards Management Group (HMG) and are therefore a consistent benchmark relative to the survey methodologies and statistical applications. The public shelter use percentages in the behavioral section of the regional hurricane evacuation study are combined with local income characteristics in the hurricane risk area (two important variables in determining public shelter use) to calculate shelter demand numbers.

For this Plan, these data served as the basis for estimating the shelter demand for coastal and inland counties between 2012 and 2017. The same methodology for projecting the vulnerable population during this period was used to calculate the estimated shelter demand figures for those years.

The Shelter Demand for the Persons with Special Needs (PSN) is also from the 2010 SRES.

### **3.2 Location and Square Footage of Existing and Needed Shelters**

Tables 3-1 and 3-2 below provide information regarding location and shelter occupant capacity of both existing and needed hurricane evacuation shelters (i.e., risk shelters) for each of the 67 Florida counties. The tables also show which regions of the state have a deficit of hurricane evacuation shelter space.

### **3.3 Pet-Friendly Shelter Availability**

A recurrent concern noted during past hurricanes is the need to provide shelters for domestic companion animals (pets). In many cases, pet-owners are unwilling to go to shelters during hurricanes due to the lack of facilities to keep their pets. Most shelters will only allow service animals. In some counties provisions have been made at local Agricultural Centers for horses and large animals. In a few cases, rooms (e.g., locker rooms) were set aside in hurricane evacuation shelters for pets that were brought anyway. Pursuant to §252.385(2)(b), Fla. Stat., this Plan includes information on the availability of shelters that accept pets.

Statewide, 27 counties provide a limited number of pet-friendly hurricane evacuation shelters that meet minimum hurricane safety criteria (i.e., ARC 4496). The pet-friendly shelters have a total human occupant capacity of 49,971 spaces. These pet-friendly shelters are designated with an “A” under the column titled: “General (G), PSN (P), Pet-Friendly (A)” in Appendix A: “List of Hurricane Evacuation Shelters by County, Location and Capacity.” It should be noted that more than 16,000 of the statewide total of 49,971 spaces are located in Bay County. Another 11 counties indicate they have designated pet-friendly hurricane evacuation shelters, but they do not meet minimum hurricane safety criteria.



Table 3-1

County	RPC Region #	General Population Shelter Demand/Capacity					Special Needs Shelter Demand/Capacity				
		2012 Category 5 Shelter Demand in People	2017 Category 5 Shelter Demand in People	2012 Risk Shelter Capacity in People	2012 Shelter Surplus/Deficit in People	2017 Shelter Surplus/Deficit in People	2012 Category 5 Shelter Demand in Clients	2017 Category 5 Shelter Demand in Clients	2012 Risk Shelter Capacity in Clients	2012 Shelter Surplus / Deficit in Clients	2017 Shelter Surplus/Deficit in Clients
Bay	1	7,328	7,802	15,311	7,983	7,509	337	358	895	558	537
Escambia	1	11,209	12,402	15,486	4,277	3,084	307	322	317	10	(5)
Holmes	1	1,026	1,056	1,332	306	276	62	63	38	(24)	(25)
Okaloosa	1	5,622	6,061	13,794	8,172	7,733	415	444	70	(345)	(374)
Santa Rosa	1	6,685	7,632	12,927	6,242	5,295	51	57	704	653	647
Walton	1	2,035	2,819	9,205	7,170	6,386	56	73	92	36	19
Washington	1	1,476	1,546	4,636	3,160	3,090	100	104	144	44	40
<b>Region 1 Subtotals</b>		<b>35,381</b>	<b>39,317</b>	<b>72,691</b>	<b>37,310</b>	<b>33,374</b>	<b>1,328</b>	<b>1,422</b>	<b>2,260</b>	<b>932</b>	<b>838</b>
Calhoun	2	1,060	1,054	172	(888)	(882)	100	100	0	(100)	(100)
Franklin	2	413	417	0	(413)	(417)	263	268	0	(263)	(268)
Gadsden	2	2,437	2,550	4,059	1,622	1,509	462	484	0	(462)	(484)
Gulf	2	506	548	460	(46)	(88)	214	231	0	(214)	(231)
Jackson	2	1,122	1,170	3,831	2,709	2,661	95	99	33	(62)	(66)
Jefferson	2	283	279	809	526	530	137	135	0	(137)	(135)
Leon	2	2,713	2,827	22,398	19,685	19,571	1,425	1,485	705	(720)	(780)
Liberty	2	214	214	1,151	937	937	130	130	76	(54)	(54)
Wakulla	2	943	1,059	800	(143)	(259)	698	784	0	(698)	(784)
<b>Region 2 Subtotals</b>		<b>9,691</b>	<b>10,117</b>	<b>33,680</b>	<b>23,989</b>	<b>23,563</b>	<b>3,524</b>	<b>3,717</b>	<b>814</b>	<b>(2,710)</b>	<b>(2,903)</b>

Table 3-1(cont.)

County	RPC Region #	General Population Shelter Demand/Capacity					Special Needs Shelter Demand/Capacity				
		2012 Category 5 Shelter Demand in People	2017 Category 5 Shelter Demand in People	2012 Risk Shelter Capacity in People	2012 Shelter Surplus/Deficit in People	2017 Shelter Surplus/Deficit in People	2012 Category 5 Shelter Demand in Clients	2017 Category 5 Shelter Demand in Clients	2012 Risk Shelter Capacity in Clients	2012 Shelter Surplus/Deficit in Clients	2017 Shelter Surplus/Deficit in Clients
Alachua	3	13,137	13,987	6,325	(6,812)	(7,662)	459	489	500	41	11
Bradford	3	1,282	1,313	1,481	199	168	194	200	214	20	14
Columbia	3	3,844	3,954	4,337	493	383	426	445	0	(426)	(445)
Dixie	3	1,502	1,570	826	(676)	(744)	148	160	0	(148)	(160)
Gilchrist	3	936	976	3,027	2,091	2,051	70	73	102	32	29
Hamilton	3	921	936	1,621	700	685	82	83	75	(7)	(8)
Lafayette	3	560	578	587	27	9	14	14	60	46	46
Madison	3	1,239	1,259	4,208	2,969	2,949	75	77	28	(47)	(49)
Suwannee	3	2,852	2,936	3,484	632	548	78	81	50	(28)	(31)
Taylor	3	1,523	1,556	3,626	2,103	2,070	72	74	0	(72)	(74)
Union	3	951	981	1,251	300	270	61	62	33	(28)	(29)
<b>Region 3 Subtotals</b>		<b>28,747</b>	<b>30,046</b>	<b>30,773</b>	<b>2,026</b>	<b>727</b>	<b>1,679</b>	<b>1,758</b>	<b>1,062</b>	<b>(617)</b>	<b>(696)</b>
Baker	4	2,698	2,696	2,663	(35)	(33)	75	77	0	(75)	(77)
Clay	4	9,039	10,235	6,036	(3,003)	(4,199)	444	504	152	(292)	(352)
Duval	4	50,878	57,112	44,248	(6,630)	(12,864)	4,385	4,706	2,377	(2,008)	(2,329)
Flagler	4	6,493	7,973	5,731	(762)	(2,242)	354	437	122	(232)	(315)
Nassau	4	4,018	4,288	4,251	233	(37)	185	204	156	(29)	(48)
Putnam	4	6,695	6,857	1,876	(4,819)	(4,981)	6	5	144	138	139



Table 3-1(cont.)

County	RPC Region #	General Population Shelter Demand/Capacity					Special Needs Shelter Demand/Capacity				
		2012 Category 5 Shelter Demand in People	2017 Category 5 Shelter Demand in People	2012 Risk Shelter Capacity in People	2012 Shelter Surplus/Deficit in People	2017 Shelter Surplus/Deficit in People	2012 Category 5 Shelter Demand in Clients	2017 Category 5 Shelter Demand in Clients	2012 Risk Shelter Capacity in Clients	2012 Shelter Surplus/Deficit in Clients	2017 Shelter Surplus/Deficit in Clients
St Johns	4	9,502	10,690	10,593	1,091	(97)	510	591	766	256	175
<b>Region 4 Subtotals</b>		<b>89,323</b>	<b>99,852</b>	<b>75,398</b>	<b>(13,925)</b>	<b>(24,454)</b>	<b>5,959</b>	<b>6,523</b>	<b>3,717</b>	<b>(2,242)</b>	<b>(2,806)</b>
Citrus	5	12,467	13,654	3,647	(8,820)	(10,007)	56	62	128	72	66
Hernando	5	11,283	12,560	12,811	1,528	251	43	48	1,414	1,371	1,366
Levy	5	4,308	4,719	2,473	(1,835)	(2,246)	19	21	136	117	115
Marion	5	21,235	23,534	12,227	(9,008)	(11,307)	107	118	852	745	734
Sumter	5	12,606	14,777	544	(12,062)	(14,233)	42	49	0	(42)	(49)
<b>Region 5 Subtotals</b>		<b>61,899</b>	<b>69,244</b>	<b>31,702</b>	<b>(30,197)</b>	<b>(37,542)</b>	<b>267</b>	<b>298</b>	<b>2,530</b>	<b>2,263</b>	<b>2,232</b>
Brevard	6	32,586	35,937	37,894	5,308	1,957	98	108	2,620	2,522	2,512
Lake	6	25,231	29,446	26,103	872	(3,343)	384	448	314	(70)	(134)
Orange	6	26,320	29,081	27,882	1,562	(1,199)	220	243	1,402	1,182	1,159
Osceola	6	7,309	8,495	30,539	23,230	22,044	37	43	1,331	1,294	1,288
Seminole	6	10,332	10,888	15,593	5,261	4,705	19	20	300	281	280
Volusia	6	38,008	53,542	20,936	(17,072)	(32,606)	241	339	2,238	1,997	1,899
<b>Region 6 Subtotals</b>		<b>139,786</b>	<b>167,388</b>	<b>158,947</b>	<b>19,161</b>	<b>(8,441)</b>	<b>999</b>	<b>1,202</b>	<b>8,205</b>	<b>7,206</b>	<b>7,003</b>
Desoto	7	3,159	3,457	2,542	(617)	(915)	571	633	211	(360)	(422)

Table 3-1(cont.)

		General Population Shelter Demand/Capacity					Special Needs Shelter Demand/Capacity				
County	RPC Region #	2012 Category 5 Shelter Demand in People	2017 Category 5 Shelter Demand in People	2012 Risk Shelter Capacity in People	2012 Shelter Surplus/Deficit in People	2017 Shelter Surplus/Deficit in People	2012 Category 5 Shelter Demand in Clients	2017 Category 5 Shelter Demand in Clients	2012 Risk Shelter Capacity in Clients	2012 Shelter Surplus/Deficit in Clients	2017 Shelter Surplus/Deficit in Clients
Hardee	7	2,167	2,444	5,693	3,526	3,249	284	320	110	(174)	(210)
Highlands	7	8,104	8,553	6,433	(1,671)	(2,120)	262	284	540	278	256
Okeechobee	7	5,295	5,752	1,822	(3,473)	(3,930)	1,271	1,398	0	(1,271)	(1,398)
Polk	7	26,570	28,502	39,081	12,511	10,579	2,338	2,519	654	(1,684)	(1,865)
<b>Region 7 Subtotals</b>		<b>45,295</b>	<b>48,708</b>	<b>55,571</b>	<b>10,276</b>	<b>6,863</b>	<b>4,726</b>	<b>5,154</b>	<b>1,515</b>	<b>(3,211)</b>	<b>(3,639)</b>
Hillsborough	8	47,195	50,797	90,955	43,760	40,158	2,446	2,650	2,480	34	(170)
Manatee	8	19,441	17,942	33,559	14,118	15,617	2,193	2,447	933	(1,260)	(1,514)
Pasco	8	25,327	26,597	29,065	3,738	2,468	2,810	2,872	1,317	(1,493)	(1,555)
Pinellas	8	42,370	43,229	31,504	(10,866)	(11,725)	7,436	7,659	2,268	(5,168)	(5,391)
<b>Region 8 Subtotals</b>		<b>134,333</b>	<b>138,565</b>	<b>185,083</b>	<b>50,750</b>	<b>46,518</b>	<b>14,885</b>	<b>15,628</b>	<b>6,998</b>	<b>(7,887)</b>	<b>(8,630)</b>
Charlotte	9	11,474	11,765	0	(11,474)	(11,765)	1,352	1,481	0	(1,352)	(1,481)
Collier	9	25,568	22,286	4,757	(20,811)	(17,529)	1,812	1,995	0	(1,812)	(1,995)
Glades	9	1,392	1,530	686	(706)	(844)	16	17	110	94	93
Hendry	9	3,721	4,097	6,263	2,542	2,166	225	245	0	(225)	(245)
Lee	9	32,216	40,245	0	(32,216)	(40,245)	2,379	2,612	0	(2,379)	(2,612)
Sarasota	9	28,209	32,738	10,759	(17,450)	(21,979)	3,076	3,431	1,616	(1,460)	(1,815)
<b>Region 9 Subtotals</b>		<b>102,580</b>	<b>112,661</b>	<b>22,465</b>	<b>(80,115)</b>	<b>(90,196)</b>	<b>8,860</b>	<b>9,781</b>	<b>1,726</b>	<b>(7,134)</b>	<b>(8,055)</b>

Table 3-1(cont.)

		General Population Shelter Demand/Capacity					Special Needs Shelter Demand/Capacity				
County	RPC Region #	2012 Category 5 Shelter Demand in People	2017 Category 5 Shelter Demand in People	2012 Risk Shelter Capacity in People	2012 Shelter Surplus/Deficit in People	2017 Shelter Surplus/Deficit in People	2012 Category 5 Shelter Demand in Clients	2017 Category 5 Shelter Demand in Clients	2012 Risk Shelter Capacity in Clients	2012 Shelter Surplus/Deficit in Clients	2017 Shelter Surplus/Deficit in Clients
Indian River	10	3,524	3,727	8,256	4,732	4,529	1,954	2,078	582	(1,372)	(1,496)
Martin	10	4,246	4,479	22,054	17,808	17,575	1,885	1,985	1,369	(516)	(616)
Palm Beach	10	28,467	30,743	70,396	41,929	39,653	5,336	5,761	800	(4,536)	(4,961)
St. Lucie	10	5,982	6,656	16,885	10,903	10,229	2,423	2,709	500	(1,923)	(2,209)
<b>Region 10 Subtotals</b>		<b>42,219</b>	<b>45,604</b>	<b>117,591</b>	<b>75,372</b>	<b>71,987</b>	<b>11,598</b>	<b>12,534</b>	<b>3,251</b>	<b>(8,347)</b>	<b>(9,283)</b>
Broward	11	25,907	26,987	56,356	30,449	29,369	1,277	1,351	1,574	297	223
Miami-Dade	11	59,177	61,350	61,455	2,278	105	2,717	2,897	3,308	591	411
Monroe	11	2,771	2,932	602	(2,169)	(2,330)	91	95	121	30	26
<b>Region 11 Subtotals</b>		<b>87,855</b>	<b>91,269</b>	<b>118,413</b>	<b>30,558</b>	<b>27,144</b>	<b>4,085</b>	<b>4,343</b>	<b>5,003</b>	<b>918</b>	<b>660</b>
<b>TOTAL</b>		<b>777,109</b>	<b>852,770</b>	<b>902,314</b>	<b>125,205</b>	<b>49,544</b>	<b>57,910</b>	<b>62,361</b>	<b>37,081</b>	<b>(20,829)</b>	<b>(25,280)</b>

Table 3-2

RPC Region #	County	General Population Shelter Demand/ Capacity					Special Needs Shelter Demand/ Capacity				
		2012 Category 5 Shelter Demand in SF (estimated)	2017 Category 5 Shelter Demand in SF (estimated)	2012 Risk Shelter Capacity in SF	2012 Shelter Surplus/ Deficit in SF	2017 Shelter Surplus/ Deficit in SF	2012 Category 5 Shelter Demand in SF (estimated)	2017 Category 5 Shelter Demand in SF (estimated)	2012 Risk Shelter Capacity in SF	2012 Shelter Surplus/ Deficit in SF	2017 Shelter Surplus/ Deficit in SF
1	BAY	146,560	156,040	306,220	159,660	150,180	20,220	21,480	53,700	33,480	32,220
1	ESCAMBIA	224,180	248,044	309,720	85,540	61,676	18,420	19,308	19,020	600	(288)
1	HOLMES	20,520	21,120	26,640	6,120	5,520	3,720	3,780	2,280	(1,440)	(1,500)
1	OKALOOSA	112,440	121,212	275,880	163,440	154,668	24,900	26,664	4,200	(20,700)	(22,464)
1	SANTA ROSA	133,700	152,632	258,540	124,840	105,908	3,060	3,444	42,240	39,180	38,796
1	WALTON	40,700	56,378	184,100	143,400	127,722	3,360	4,387	5,520	2,160	1,133
1	WASHINGTON	29,520	30,915	92,720	63,200	61,805	6,000	6,254	8,640	2,640	2,386
	<b>Region 1 Totals:</b>	<b>707,620</b>	<b>786,341</b>	<b>1,453,820</b>	<b>746,200</b>	<b>667,479</b>	<b>79,680</b>	<b>85,317</b>	<b>135,600</b>	<b>55,920</b>	<b>50,283</b>
2	CALHOUN	21,200	21,084	3,440	(17,760)	(17,644)	6,000	5,989	0	(6,000)	(5,989)
2	FRANKLIN	8,260	8,334	0	(8,260)	(8,334)	15,780	16,099	0	(15,780)	(16,099)
2	GADSDEN	48,740	50,998	81,180	32,440	30,182	27,720	29,045	0	(27,720)	(29,045)
2	GULF	10,120	10,950	9,200	(920)	(1,750)	12,840	13,890	0	(12,840)	(13,890)
2	JACKSON	22,440	23,398	76,620	54,180	53,222	5,700	5,945	1,980	(3,720)	(3,965)
2	JEFFERSON	5,660	5,575	16,180	10,520	10,605	8,220	8,114	0	(8,220)	(8,114)
2	LEON	54,260	56,536	447,960	393,700	391,424	85,500	89,113	42,300	(43,200)	(46,813)
2	LIBERTY	4,280	4,271	23,020	18,740	18,749	7,800	7,826	4,560	(3,240)	(3,266)

RPC Region #	County	General Population Shelter Demand/ Capacity					Special Needs Shelter Demand/ Capacity				
		2012 Category 5 Shelter Demand in SF (estimated)	2017 Category 5 Shelter Demand in SF (estimated)	2012 Risk Shelter Capacity in SF	2012 Shelter Surplus/ Deficit in SF	2017 Shelter Surplus/ Deficit in SF	2012 Category 5 Shelter Demand in SF (estimated)	2017 Category 5 Shelter Demand in SF (estimated)	2012 Risk Shelter Capacity in SF	2012 Shelter Surplus/ Deficit in SF	2017 Shelter Surplus/ Deficit in SF
2	WAKULLA	18,860	21,184	16,000	(2,860)	(5,184)	41,880	47,027	0	(41,880)	(47,027)
	<b>Region 2 Totals:</b>	<b>193,820</b>	<b>202,331</b>	<b>673,600</b>	<b>479,780</b>	<b>471,269</b>	<b>211,440</b>	<b>223,048</b>	<b>48,840</b>	<b>(162,600)</b>	<b>(174,208)</b>
3	ALACHUA	262,740	279,749	126,500	(136,240)	(153,249)	27,540	29,315	30,000	2,460	686
3	BRADFORD	25,640	26,267	29,620	3,980	3,353	11,640	11,978	12,840	1,200	862
3	COLUMBIA	76,880	79,072	86,740	9,860	7,668	25,560	26,725	0	(25,560)	(26,725)
3	DIXIE	30,040	31,409	16,520	(13,520)	(14,889)	8,880	9,572	0	(8,880)	(9,572)
3	GILCHRIST	18,720	19,512	60,540	41,820	41,028	4,200	4,404	6,120	1,920	1,716
3	HAMILTON	18,420	18,718	32,420	14,000	13,702	4,920	4,986	4,500	(420)	(486)
3	LAFAYETTE	11,200	11,557	11,740	540	183	840	849	3,600	2,760	2,751
3	MADISON	24,780	25,185	84,160	59,380	58,975	4,500	4,605	1,680	(2,820)	(2,925)
3	SUWANNEE	57,040	58,723	69,680	12,640	10,957	4,680	4,850	3,000	(1,680)	(1,850)
3	TAYLOR	30,460	31,113	72,520	42,060	41,407	4,320	4,462	0	(4,320)	(4,462)
3	UNION	19,020	19,611	25,020	6,000	5,409	3,660	3,748	1,980	(1,680)	(1,768)
	<b>Region 3 Totals:</b>	<b>574,940</b>	<b>600,916</b>	<b>615,460</b>	<b>40,520</b>	<b>14,544</b>	<b>100,740</b>	<b>105,493</b>	<b>63,720</b>	<b>(37,020)</b>	<b>(41,773)</b>
4	BAKER	53,960	53,923	53,260	(700)	(663)	4,500	4,610	0	(4,500)	(4,610)
4	CLAY	180,780	204,707	120,720	(60,060)	(83,987)	26,640	30,218	9,120	(17,520)	(21,098)
4	DUVAL	1,017,560	1,142,245	884,960	(132,600)	(257,285)	263,100	282,344	142,620	(120,480)	(139,724)
4	FLAGLER	129,860	159,461	114,620	(15,240)	(44,841)	21,240	26,216	7,320	(13,920)	(18,896)

Table 3-2

RPC Region #	County	General Population Shelter Demand/ Capacity					Special Needs Shelter Demand/ Capacity				
		2012 Category 5 Shelter Demand in SF (estimated)	2017 Category 5 Shelter Demand in SF (estimated)	2012 Risk Shelter Capacity in SF	2012 Shelter Surplus/ Deficit in SF	2017 Shelter Surplus/ Deficit in SF	2012 Category 5 Shelter Demand in SF (estimated)	2017 Category 5 Shelter Demand in SF (estimated)	2012 Risk Shelter Capacity in SF	2012 Shelter Surplus/ Deficit in SF	2017 Shelter Surplus/ Deficit in SF
4	NASSAU	80,360	85,768	85,020	4,660	(748)	11,100	12,217	9,360	(1,740)	(2,857)
4	PUTNAM	133,900	137,135	37,520	(96,380)	(99,615)	360	315	8,640	8,280	8,325
4	ST.JOHN	190,040	213,800	211,860	21,820	(1,940)	30,600	35,461	45,960	15,360	10,499
	<b>Region 4 Totals:</b>	<b>1,786,460</b>	<b>1,997,039</b>	<b>1,507,960</b>	<b>(278,500)</b>	<b>(489,079)</b>	<b>357,540</b>	<b>391,382</b>	<b>223,020</b>	<b>(134,520)</b>	<b>(168,362)</b>
5	CITRUS	249,340	273,086	72,940	(176,400)	(200,146)	3,360	3,703	7,680	4,320	3,977
5	HERNANDO	225,660	251,202	256,220	30,560	5,018	2,580	2,875	84,840	82,260	81,965
5	LEVY	86,160	94,373	49,460	(36,700)	(44,913)	1,140	1,280	8,160	7,020	6,880
5	MARION	424,700	470,675	244,540	(180,160)	(226,135)	6,420	7,096	51,120	44,700	44,024
5	SUMTER	252,120	295,541	10,880	(241,240)	(284,661)	2,520	2,936	0	(2,520)	(2,936)
	<b>Region 5 Totals:</b>	<b>1,237,980</b>	<b>1,384,877</b>	<b>634,040</b>	<b>(603,940)</b>	<b>(750,837)</b>	<b>16,020</b>	<b>17,889</b>	<b>151,800</b>	<b>135,780</b>	<b>133,911</b>
6	BREVARD	651,720	718,737	757,880	106,160	39,143	5,880	6,488	157,200	151,320	150,712
6	LAKE	504,620	588,912	522,060	17,440	(66,852)	23,040	26,905	18,840	(4,200)	(8,065)
6	ORANGE	526,400	581,612	557,640	31,240	(23,972)	13,200	14,603	84,120	70,920	69,517
6	OSCEOLA	146,180	169,906	610,780	464,600	440,874	2,220	2,561	79,860	77,640	77,299
6	SEMINOLE	206,640	217,767	311,860	105,220	94,093	1,140	1,178	18,000	16,860	16,822
6	VOLUSIA	760,160	1,070,831	418,720	(341,440)	(652,111)	14,460	20,367	134,280	119,820	113,913
	<b>Region 6 Totals:</b>	<b>2,795,720</b>	<b>3,347,766</b>	<b>3,178,940</b>	<b>383,220</b>	<b>(168,826)</b>	<b>59,940</b>	<b>72,103</b>	<b>492,300</b>	<b>432,360</b>	<b>420,197</b>

RPC Region #	County	General Population Shelter Demand/ Capacity					Special Needs Shelter Demand/ Capacity				
		2012 Category 5 Shelter Demand in SF (estimated)	2017 Category 5 Shelter Demand in SF (estimated)	2012 Risk Shelter Capacity in SF	2012 Shelter Surplus/ Deficit in SF	2017 Shelter Surplus/ Deficit in SF	2012 Category 5 Shelter Demand in SF (estimated)	2017 Category 5 Shelter Demand in SF (estimated)	2012 Risk Shelter Capacity in SF	2012 Shelter Surplus/ Deficit in SF	2017 Shelter Surplus/ Deficit in SF
7	DESOTO	63,180	69,139	50,840	(12,340)	(18,299)	34,260	37,983	12,660	(21,600)	(25,323)
7	HARDEE	43,340	48,872	113,860	70,520	64,988	17,040	19,223	6,600	(10,440)	(12,623)
7	HIGHLANDS	162,080	171,058	128,660	(33,420)	(42,398)	15,720	17,047	32,400	16,680	15,353
7	OKEECHOBEE	105,900	115,047	36,440	(69,460)	(78,607)	76,260	83,859	0	(76,260)	(83,859)
7	POLK	531,400	570,039	781,620	250,220	211,581	140,280	151,143	39,240	(101,040)	(111,903)
	<b>Region 7 Totals:</b>	<b>905,900</b>	<b>974,155</b>	<b>1,111,420</b>	<b>205,520</b>	<b>137,265</b>	<b>283,560</b>	<b>309,255</b>	<b>90,900</b>	<b>(192,660)</b>	<b>(218,355)</b>
8	HILLSBOROUGH	943,900	1,015,933	1,819,100	875,200	803,167	146,760	159,021	148,800	2,040	(10,221)
8	MANATEE	388,820	358,845	671,180	282,360	312,335	131,580	146,806	55,980	(75,600)	(90,826)
8	PASCO	506,540	531,942	581,300	74,760	49,358	168,600	172,315	79,020	(89,580)	(93,295)
8	PINELLAS	847,400	864,583	630,080	(217,320)	(234,503)	446,160	459,530	136,080	(310,080)	(323,450)
	<b>Region 8 Totals:</b>	<b>2,686,660</b>	<b>2,771,303</b>	<b>3,701,660</b>	<b>1,015,000</b>	<b>930,357</b>	<b>893,100</b>	<b>937,672</b>	<b>419,880</b>	<b>(473,220)</b>	<b>(517,792)</b>
9	CHARLOTTE	229,480	235,295	0	(229,480)	(235,295)	81,120	88,874	0	(81,120)	(88,874)
9	COLLIER	511,360	445,723	95,140	(416,220)	(350,583)	108,720	119,692	0	(108,720)	(119,692)
9	GLADES	27,840	30,604	13,720	(14,120)	(16,884)	960	1,008	6,600	5,640	5,592
9	HENDRY	74,420	81,931	125,260	50,840	43,329	13,500	14,726	0	(13,500)	(14,726)
9	LEE	644,320	804,906	0	(644,320)	(804,906)	142,740	156,703	0	(142,740)	(156,703)
9	SARASOTA	564,180	654,761	215,180	(349,000)	(439,581)	184,560	205,856	96,960	(87,600)	(108,896)

RPC Region #	County	General Population Shelter Demand/ Capacity					Special Needs Shelter Demand/ Capacity				
		2012 Category 5 Shelter Demand in SF (estimated)	2017 Category 5 Shelter Demand in SF (estimated)	2012 Risk Shelter Capacity in SF	2012 Shelter Surplus/ Deficit in SF	2017 Shelter Surplus/ Deficit in SF	2012 Category 5 Shelter Demand in SF (estimated)	2017 Category 5 Shelter Demand in SF (estimated)	2012 Risk Shelter Capacity in SF	2012 Shelter Surplus/ Deficit in SF	2017 Shelter Surplus/ Deficit in SF
	<b>Region 9 Totals:</b>	2,051,600	2,253,221	449,300	(1,602,300)	(1,803,921)	531,600	586,857	103,560	(428,040)	(483,297)
10	INDIAN RIVER	70,480	74,541	165,120	94,640	90,580	117,240	124,679	34,920	(82,320)	(89,759)
10	MARTIN	84,920	89,573	441,080	356,160	351,507	113,100	119,122	82,140	(30,960)	(36,982)
10	PALM BEACH	569,340	614,854	1,407,920	838,580	793,066	320,160	345,679	48,000	(272,160)	(297,679)
10	ST.LUCIE	119,640	133,115	337,700	218,060	204,585	145,380	162,555	30,000	(115,380)	(132,555)
	<b>Region 10 Totals:</b>	844,380	912,082	2,351,820	1,507,440	1,439,738	695,880	752,035	195,060	(500,820)	(556,975)
11	BROWARD	518,140	539,745	1,127,120	608,980	587,375	76,620	81,044	94,440	17,820	13,396
11	MIAMI-DADE	1,183,540	1,226,992	1,229,100	45,560	2,108	163,020	173,844	198,480	35,460	24,636
11	MONROE	55,420	58,642	12,040	(43,380)	(46,602)	5,460	5,693	7,260	1,800	1,567
	<b>Region 11 Totals:</b>	1,757,100	1,825,380	2,368,260	611,160	542,880	245,100	260,581	300,180	55,080	39,599
	<b>Totals</b>	15,542,180	17,055,409	18,046,280	2,504,100	990,871	3,474,600	3,741,632	2,224,860	(1,249,740)	(1,516,772)



#### **4.0 TYPES OF PUBLIC FACILITIES THAT SHOULD COMPLY WITH PUBLIC SHELTER DESIGN CRITERIA**

By statute, all appropriate public facilities are subject to being used as public hurricane evacuation shelters in a declared state or local emergency. See §252.385, Fla. Stat. Therefore, any appropriate new public facility should include emergency shelter criteria. This includes not only public educational facilities, but also certain types of state and local government facilities. In general, facilities that are designed for public assembly, either as a primary or auxiliary use, may be appropriate for use as public shelters during an emergency. At this time, only public educational facilities are subject to the EHPA criteria by statute and code. This is primarily due to the fact that public educational facilities account for more than 99 percent of current public hurricane evacuation shelter space, and relatively few other state and local facilities are appropriate for use as public shelters.

The public shelter space may be located in a single building or a campus or office center with multiple buildings, placed in a single large room or multiple medium sized rooms in close proximity to each other, or in one or more stories of multistory buildings. Preferably the buildings will have a means of inside circulation and convenient access to toilets.

To determine if a proposed new public facility should be subject to the EHPA criteria, regardless of non-educational function or agency with ownership, the proposed facility should be reviewed based upon the exemption criteria given in Section 2.2 of this Plan. Facilities not subject to an exemption may be appropriate for use as public hurricane evacuation shelters. The decision to incorporate emergency shelter criteria into a new public facility must be coordinated with the local emergency management agency(s) or the Division.

##### **4.1 Public Schools and Community Colleges**

District public schools (K-12) are the primary source of public hurricane evacuation shelter space in Florida, accounting for about 97 percent of current capacity. This is due to the fact that schools are widely distributed in populated areas, school facilities are designed for large assembly occupancies with many inherent mass care features (e.g., adequate quantity of toilets, dining/feeding areas, etc.), access to the facilities can be coordinated through a single local agency, etc. The types of school buildings that are potentially appropriate for use as public shelters include gymnasiums, cafeteria/dining, multipurpose, auditoriums and certain classroom buildings.

Community colleges account for only about one (1) percent of current public shelter capacity. Community colleges are regionally distributed, and potentially located in areas with high demands for public hurricane evacuation shelter space. As with K-12 public schools, community colleges are normally designed for large assembly occupancies and possess many inherent mass care features. The types of college buildings that are potentially appropriate for use as public shelters include gymnasiums, cafeterias, multipurpose facilities, auditoriums and certain classroom buildings.

## **4.2 Charter Schools**

Charter schools appear to have a general exemption from meeting many of the requirements of K-12 public schools; reference §1002.33(16)(a), Fla. Stat. However, §1002.33(18), Fla. Stat. requires charter schools to utilize facilities which comply with the generally applicable provisions of the Florida Building Code, and may opt to comply with the State Requirements of Educational Facilities (SREF).

Charter schools may be used to expand the capacity of the public school system. Therefore, under some circumstances, a charter school may replace construction of a new public school facility within a geographic area of a county or region where there is significant demand for public hurricane evacuation shelter space. In this situation, a new public school facility would be lawfully required by statute and code to incorporate the EHPA criteria. Charter schools are exempt from EHPA criteria which therefore limits the ability of both the board and emergency management agencies to reduce the public hurricane evacuation shelter space deficit.

Charter schools may be eligible to receive state capital outlay, local capital millage, and impact fee funding to support construction, operation, maintenance, repair or other purposes, and such facilities, when located on district property, are subject to reversion to the district school board in the event that a charter school terminates operation. Given the public investment in the facilities, and the magnitude of the hurricane evacuation shelter space deficit in certain regions and counties, charter schools, when possible, should include the EHPA criteria.

The following are factors to be considered in determining if a proposed new construction charter school facility should incorporate the EHPA criteria: 1) are local capital millage or impact fee funds supporting the construction project; 2) does the project meet the definition of “new construction” as defined in §1013.01(14), Fla. Stat. or s. 423.5.8, *Florida Building Code--Building*; 3) would the facility be subject to an exemption per §1013.372(1), Fla. Stat. or s. 423.5.8, *Florida Building Code--Building* due its location, size or other characteristic; 4) would the facility be subject to reversion to the district board if charter school operations terminate; or 5) will the facility be subject to use as a public hurricane evacuation shelter per §252.385(4)(a), Fla. Stat., because it is owned or leased by a state or local governmental entity.

## **4.3 State Universities**

State university facilities account for only about one (1) percent of current public hurricane evacuation shelter capacity. Unlike K-12 public schools and community colleges, state university campuses may not be as widely distributed, though several are potentially located in areas with high demands for public hurricane evacuation shelter space (e.g., Florida International University, University of South Florida, etc.) Main campuses and some satellite campuses may have several appropriate buildings concentrated in one (or more) proximate geographic area. This concentration of shelter spaces reduces staffing and logistical resource demands of a sheltering operation.

State university facilities are normally designed for large assembly occupancies, with many having inherent mass care features. The types of university buildings that are potentially appropriate for use as public shelters include gymnasiums, field houses and sports arenas, cafeterias or dining rooms, multipurpose facilities, auditoriums and certain classroom buildings.

State universities must consider two separate populations when developing their public shelter strategies: 1) campus staff, faculty and their families, and students (both commuters and residential); and 2) the general public. University facilities may be designated for sole use by one population, or concurrent use by both populations, at the discretion of the university board with the concurrence of local emergency management agency or the Division. Residential facilities are not normally subject to the EHPA criteria, but incorporation of the criteria into new residential housing or dormitories (or portions thereof) will free up additional hurricane evacuation shelter space for the general public in appropriate non-residential facilities.

#### **4.4 State and Local Public Facilities**

Local public facilities account for about one (1) percent of current public hurricane evacuation shelter capacity. Given their administrative function (and essential emergency function of certain facilities) most state-owned, county-owned and municipally-owned facilities are not appropriate for use as public hurricane evacuation shelters. Administrative office and support areas, data and word processing rooms and areas, record vaults, etc., are exempt from the EHPA criteria. However, certain other types of public facilities may be appropriate, such as community or civic centers, meeting halls, auditoriums, exhibition halls, sports arenas, conference or training centers, and other public assembly facilities.

## 5.0 RECOMMENDED SOURCES OF FUNDING

School districts have generally been reporting that the construction cost premium for incorporating the EHPA code provisions can range from less than one (1) to as much as 20 percent, though the average is about four (4) percent. For most new facilities, this appears to translate into a construction cost premium of less than \$900,000. These are not necessarily inconsequential costs that must be borne by State and local governments. Therefore, pursuant to §1013.372(2), Fla. Stat., the Division recommends use of existing state capital outlay funds to fund the additional cost of constructing hurricane evacuation shelters in public schools.

### 5.1 Public Schools, Community Colleges and University Facilities

The only applicable funding source at this time for district public schools, community colleges and universities is Public Education Capital Outlay (PECO) funds. These funds are appropriated for site acquisition and improvements necessary to accommodate buildings, equipment, and other structures of district school boards, community colleges and universities. The Division recommends the use of these as they are an appropriate and available source of State funding.

Table 5-1 provides a summary of estimated PECO funds that have been distributed to local school boards from Fiscal Year 1997/98, when the EHPA requirement was promulgated into code, through Fiscal Year 2011/12. The PECO funding information was provided by the Department of Education. Universities and community colleges are not included in Table 5-1 due to the fact that only about two (2) percent of the statewide public hurricane evacuation shelter capacity is located on their campuses. The ratio column provides a means of comparing EHPA production versus PECO funds distributed over the past 15 years that the EHPA has been a code requirement. The average PECO funds distributed per EHPA space created was \$6,064. School boards with comparison values near or below this average were more productive than those that are significantly higher than either the average or have a zero (0) value.

<b>Table 5-1. Estimate of PECO Funds Distributed to School Districts 1997 – 2012 Comparison to EHPA Spaces Created</b>			
<b>County</b>	<b>New Construction PECO Funds, \$</b>	<b>Cumulative EHPA Spaces @ 20 sq.ft. each</b>	<b>Ratio of PECO Funds Received to EHPA Spaces Built, \$</b>
Alachua	\$13,689,553	807	\$16,963.51
Baker	\$3,303,969	306	\$10,797.28
Bay	\$12,743,041	1,558	\$8,179.10
Bradford	\$1,879,416	0	\$0.00
Brevard	\$34,339,175	13,203	\$2,600.86
Broward	\$184,443,426	60,578	\$3,044.73
Calhoun	\$964,478	172	\$5,607.43
Charlotte	\$12,165,585	0	\$0.00
Citrus	\$10,910,548	384	\$28,412.89

<b>Table 5-1. Estimate of PECO Funds Distributed to School Districts 1997 – 2012 Comparison to EHPA Spaces Created</b>			
<b>County</b>	<b>New Construction PECO Funds, \$</b>	<b>Cumulative EHPA Spaces @ 20 sq.ft. each</b>	<b>Ratio of PECO Funds Received to EHPA Spaces Built, \$</b>
Clay	\$40,712,028	3,027	\$13,449.63
Collier	\$40,485,589	0	\$0.00
Columbia	\$5,575,730	4,337	\$1,285.62
Dade	\$180,055,515	20,226	\$8,902.18
Desoto	\$2,414,272	0	\$0.00
Dixie	\$1,388,354	0	\$0.00
Duval	\$50,761,462	16,725	\$3,035.06
Escambia	\$16,956,713	1,995	\$8,499.61
Flagler	\$25,476,339	969	\$26,291.37
Franklin	\$507,654	0	\$0.00
Gadsden	\$3,317,022	2,142	\$1,548.56
Gilchrist	\$1,604,565	0	\$0.00
Glades	\$823,387	608	\$1,354.25
Gulf	\$1,524,961	228	\$6,688.43
Hamilton	\$983,128	1,345	\$730.95
Hardee	\$2,890,964	5,693	\$507.81
Hendry	\$3,592,162	1,000	\$3,592.16
Hernando	\$25,249,589	9,777	\$2,582.55
Highlands	\$7,597,367	5,097	\$1,490.56
Hillsborough	\$145,844,289	67,199	\$2,170.33
Holmes	\$1,484,783	1,267	\$1,171.89
Indian River	\$11,338,760	1,746	\$6,494.14
Jackson	\$4,645,987	3,431	\$1,354.12
Jefferson	\$615,491	809	\$760.80
Lafayette	\$951,389	0	\$0.00
Lake	\$45,040,584	2,4737	\$1,820.78
Lee	\$70,798,993	0	\$0.00
Leon	\$16,774,739	1,245	\$13,473.69
Levy	\$4,033,620	276	\$14,614.57
Liberty	\$1,392,240	762	\$1,827.09
Madison	\$1,265,618	0	\$0.00
Manatee	\$31,819,893	23,956	\$1,328.26
Marion	\$37,872,640	6,558	\$5,775.03
Martin	\$13,407,274	8,286	\$1,618.06
Monroe	\$3,304,335	0	\$0.00
Nassau	\$9,547,176	4,393	\$2,173.27
Okaloosa	\$11,048,934	0	\$0.00

<b>Table 5-1. Estimate of PECO Funds Distributed to School Districts 1997 – 2012 Comparison to EHPA Spaces Created</b>			
<b>County</b>	<b>New Construction PECO Funds, \$</b>	<b>Cumulative EHPA Spaces @ 20 sq.ft. each</b>	<b>Ratio of PECO Funds Received to EHPA Spaces Built, \$</b>
Okeechobee	\$3,724,303	1,011	\$3,683.78
Orange	\$123,498,036	29,942	\$4,124.58
Osceola	\$61,043,263	13,862	\$4,403.64
Palm Beach	\$113,927,836	51,856	\$2,197.00
Pasco	\$74,299,046	18,951	\$3,920.59
Pinellas	\$61,320,950	11,132	\$5,508.53
Polk	\$86,231,095	39,414	\$2,187.83
Putnam	\$5,079,243	1,243	\$4,086.28
St. Johns	\$42,032,738	8,241	\$5,100.44
St. Lucie	\$56,302,558	5,390	\$10,445.74
Santa Rosa	\$22,306,259	7,413	\$3,009.07
Sarasota	\$34,599,582	6,824	\$5,070.28
Seminole	\$37,076,435	1,000	\$37,076.44
Sumter	\$2,685,199	200	\$13,426.00
Suwannee	\$4,300,520	3,484	\$1,234.36
Taylor	\$1,923,026	2,424	\$793.33
Union	\$1,357,200	411	\$3,302.19
Volusia	\$34,271,387	9,469	\$3,619.32
Wakulla	\$5,581,785	800	\$6,977.23
Walton	\$5,739,252	5,269	\$1,089.25
Washington	\$3,126,912	1,459	\$2,143.19
<b>Totals</b>	<b>1,877,969,362</b>	<b>514,637</b>	<b>\$6,064.47</b>
* - Spaces shown have been adjusted to reflect Persons with Special Needs (PSN) space capacity at an equivalent rate of three (3) times the general population (GP) spaces (i.e., 1 PSN space @ 60 sf each = 3 GP spaces @ 20 sf each). Note: <u>\$6,064.47</u> is an average of the ratios, less those with a value of "\$0".			

The Department of Education also reported that under the Classrooms for Kids (CFK) program the state has distributed an additional \$2.5 Billion in capital outlay funds. The CFK funds are allocated to reduce class sizes and can be used for construction, renovation, remodel or repair of permanent facilities, or purchase or lease-purchase of relocatables. Since some of these activities are not subject to EHPA code requirements they have not been included in Table 5-1. The CFK funds were derived from Lottery proceeds, General Revenue and PECO funds.

## 5.2 Hurricane Hazard Mitigation Funds

From time to time, some federal and state mitigation-related funds may be available to support the construction cost premium for improving hurricane-resistance **above** minimum code requirements for new facilities. By example, some mitigation programs may share the cost of increasing the design wind speed by the EHPA criteria's recommended 40 miles per hour increase in design wind speed or to the ICC 500 hurricane wind and flood design standards. The principal Federal/State mitigation program is the Hazard Mitigation Grant Program (HMGP). However, the HMGP is not considered "available" for most new construction projects because its grant cycles are often tied to Federal disaster declarations. The HMGP also has a pre-disaster mitigation (PDM) grant cycle which is nationally competitive. Information on the mitigation programs can be obtained through state and local emergency management agencies.

## **6.0 STATEWIDE PROGRESS TOWARD ELIMINATING THE PUBLIC HURRICANE EVACUATION SHELTER SPACE DEFICIT**

The Florida Division of Emergency Management is charged under §252.385, Fla. Stat. to administer a statewide program to eliminate the deficit of “safe” hurricane evacuation shelter space. The Division has taken several steps to implement the program. First, by conducting a survey of existing buildings, both public and private, to identify suitable shelter capacity. Second, where cost effective (and practical), support mitigation and retrofitting of facilities to increase shelter capacity. Third, require construction of new educational facilities to meet the EHPA criteria. Fourth, conduct research to clearly identify demand. And fifth, improve public information/education to reduce shelter demand from evacuees not required to evacuate or “shadow” evacuations.

Since 1995, the Division has been performing a survey of existing designated and potential hurricane evacuation shelters. The initial findings of the survey were not encouraging. The vast majority of the designated hurricane evacuation shelters were in buildings that did not meet the ARC 4496 guidelines. As examples, the pre-survey designated hurricane evacuation shelters rarely had adequate (if any) window protection (83 percent without protection), and were often constructed with long span roofs (41 percent with long span) and unreinforced masonry walls (43 percent with unreinforced masonry). The initial results of the survey began, for the first time, to quantify the actual condition of Florida’s hurricane evacuation shelter inventory, instead of relying on anecdotal concerns that had been expressed for more than 20 years. However, during the survey process, hundreds of thousands of spaces were identified that only required minor retrofitting (e.g., window protection) to meet the ARC 4496 guidelines.

Between 1995 and 2000, the reported hurricane evacuation shelter space deficit increased considerably; from about 361,000 spaces in 1996 to more than 1.5 million in 2000. During this time-frame, less than 200,000 hurricane evacuation shelter spaces that meet minimum hurricane evacuation shelter safety criteria could be documented. The spaces that could be documented were located primarily in the southeastern and east-central coastal regions of the state. This capacity was principally the result of post-Hurricane Andrew HMGP funding of public school window protection projects. Other than federal HMGP funds, no significant source of funding had been identified to support the minor retrofit projects being documented during the survey process.

Concurrently, §235.26(9)(a), Fla. Stat. (superseded by §1013.372(1), Fla. Stat.) stated that all new educational facilities for which a design contract was entered into after July 1, 1995 were required to incorporate the public shelter design criteria. However, the criteria did not become effective until April 28, 1997. It is not unusual for there to be a three-year delay between promulgation of a building code (or rule) and availability of the first group of compliant facilities. Therefore, minimal progress was made prior to 2000 via construction of new public schools to the EHPA criteria.

By 2000, the reported hurricane evacuation shelter space deficit peaked as the strategy originally directed by Chapter 93-211, Laws of Florida, began to produce results. As a benchmark, the *2000 Statewide Emergency Shelter Plan* reported that Florida had a



statewide hurricane evacuation shelter space deficit of more than 1.5 million spaces. This reported deficit affected every region of the state, but especially the southern and central regions of the peninsula. This did not imply that in any given storm that 1.5 million evacuees would simultaneously seek public shelter, but reflected the State's cumulative hurricane evacuation shelter space deficit. State and local emergency managers and other public officials prefer that persons ordered to evacuate for a hurricane stay within their home county or region, and not evacuate long distances. The *2000 Statewide Emergency Shelter Plan's* published statewide and regional deficits served to quantify the challenge that lay ahead.

In 1999, the State Legislature appropriated more than \$2.2 million to support a hurricane evacuation shelter retrofitting initiative. The appropriation stipulated that the funds be used to shutter school buildings for use as hurricane evacuation shelters. The Division used the *1999 Shelter Retrofit Report* to identify and prioritize projects to receive the funds. A total of 58 projects were selected, which created an estimated 34,928 spaces. In 2000, the State Legislature appropriated an additional \$18 million (combined Federal, State and local funds) to complete the projects listed in the *1999 Shelter Retrofit Report*. The 2000 appropriation included funds from the Hurricane(s) Floyd and Irene (Federal HMGP declaration), which were earmarked to support the state's effort to reduce the deficit of hurricane evacuation shelter space.

Since 1995, through Federal, State, and local retrofitting of appropriate facilities, Florida has created a total of 405,325 public hurricane evacuation shelter spaces. The "Retrofitting / Mitigated Capacity Gained" column of Table 6-1 demonstrates county-by-county progress toward eliminating the hurricane evacuation shelter space deficit by retrofitting appropriate facilities to meet ARC 4496. Retrofitting facilities account for about 43 percent of the state's total capacity of ARC 4496 hurricane evacuation shelter spaces. The majority of this retrofit capacity has been created since 1999. Though regions and counties with the greatest deficits received priority for available retrofit funds, there has been a more widespread distribution of the retrofit funds due to the statewide nature of the deficit. Some of the retrofitted facilities have less than preferred mass care characteristics (e.g., inconveniently located toilet facilities, etc.), but the retrofit program produced a rapid improvement in the safety of Florida's hurricane evacuation shelter inventory.

Creation of hurricane evacuation shelter capacity through construction of new school facilities to the EHPA criteria has also increased since 1999. Local emergency management and school board officials have reported that 480,312 EHPA shelters spaces have been created. The "EHPA Capacity Gained" column of Table 6-1 demonstrates county-by-county progress toward eliminating the hurricane evacuation shelter space deficit via EHPA construction. The application of the EHPA criteria has been inconsistent across the state, with several counties reporting construction of relatively few (if any) EHPA's. EHPA spaces account for about 51 percent of the state's total capacity of ARC 4496 hurricane evacuation shelter spaces. However, as with any program, "institutionalization" takes time to evolve, and progress is being made.

Some 53,758 spaces were identified through surveys as meeting ARC 4496 guidelines (“as-is”) without further retrofitting needed. These facilities, however, did not meet all the EHPA code requirements. These Pre-Mitigation ARC 4496 spaces account for about 6 percent of the state’s total spaces.

<b>TABLE 6-1 Hurricane Evacuation Shelter Spaces Identified Since 1995</b>				
<b>County</b>	<b>Pre-Mitigation ARC 4496 Capacity, spaces</b>	<b>EHPA Capacity Gained, spaces</b>	<b>Retrofitted / Mitigated Capacity Gained, spaces</b>	<b>Total ARC 4496 Capacity Gained, spaces</b>
ALACHUA	0	0	6,325	6,325
BAKER	0	306	2,357	2,663
BAY	0	655	14,656	15,311
BRADFORD	0	0	1,481	1,481
BREVARD	1,316	9,063	27,515	37,894
BROWARD	500	55,856	0	56,356
CALHOUN	0	172	0	172
CHARLOTTE	0	0	0	0
CITRUS	0	0	3,647	3,647
CLAY	0	3,027	3,009	6,036
COLLIER	0	0	4,757	4,757
COLUMBIA	0	4,337	0	4,337
DESOTO	0	0	2,542	2,542
DIXIE	0	0	826	826
DUVAL	1,092	13,971	29,185	44,248
ESCAMBIA	254	1,995	13,237	15,486
FLAGLER	3,191	603	1,937	5,731
FRANKLIN	0	0	0	0
GADSDEN	0	2,142	1,917	4,059
GILCHRIST	0	0	3,027	3,027
GLADES	0	278	408	686
GULF	232	228	0	460
HAMILTON	0	1,120	501	1,621
HARDEE	0	5,693	0	5,693
HENDRY	939	1,000	4,324	6,263
HERNANDO	1,310	8,982	2,519	12,811
HIGHLANDS	1,136	5,097	200	6,433
HILLSBOROUGH	446	64,949	25,560	90,955
HOLMES	0	1,153	179	1,332

<b>TABLE 6-1 Hurricane Evacuation Shelter Spaces Identified Since 1995</b>				
<b>County</b>	<b>Pre-Mitigation ARC 4496 Capacity, spaces</b>	<b>EHPA Capacity Gained, spaces</b>	<b>Retrofitted / Mitigated Capacity Gained, spaces</b>	<b>Total ARC 4496 Capacity Gained, spaces</b>
INDIAN RIVER	0	0	8,256	8,256
JACKSON	0	3,332	499	3,831
JEFFERSON	0	809	0	809
LAFAYETTE	0	0	587	587
LAKE	0	23,795	2,308	26,103
LEE	0	0	0	0
LEON	822	1,245	20,331	22,398
LEVY	70	276	2,127	2,473
LIBERTY	0	534	617	1,151
MADISON	0	0	4,208	4,208
MANATEE	0	21,157	12,402	33,559
MARION	0	6,192	6,035	12,227
MARTIN	7,815	5,079	9,160	22,054
MIAMI-DADE	5,652	17,142	38,661	61,455
MONROE	0	0	602	602
NASSAU	0	3,925	326	4,251
OKALOOSA	6,430	0	7,364	13,794
OKEECHOBEE	0	1,011	811	1,822
ORANGE	1,671	25,736	475	27,882
OSCEOLA	0	12,212	18,327	30,539
PALM BEACH	0	51,106	19,290	70,396
PASCO	0	17,496	11,569	29,065
PINELLAS	12,423	8,717	10,364	31,504
POLK	1,007	37,452	622	39,081
PUTNAM	0	811	1,065	1,876
SANTA ROSA	383	7,413	5,131	12,927
SARASOTA	0	3,551	7,208	10,759
SEMINOLE	0	1,000	14,593	15,593
ST.JOHN'S	0	6,741	3,852	10,593
ST.LUCIE	3,584	4,388	8,913	16,885
SUMTER	0	200	344	544
SUWANNEE	0	3,484	0	3,484
TAYLOR	0	2,424	1,202	3,626
UNION	0	312	939	1,251
VOLUSIA	2,223	7,012	11,701	20,936
WAKULLA	0	800	0	800
WALTON	1,262	5,269	2,674	9,205
WASHINGTON	0	1,027	3,609	4,636
<b>Totals- General Population</b>	<b>53,758</b>	<b>462,275</b>	<b>386,281</b>	<b>902,314</b>
<b>Totals Special Needs</b>	<b>0</b>	<b>18,037</b>	<b>19,044</b>	<b>37,081</b>
<b>Grand Totals</b>	<b>53,758</b>	<b>480,312</b>	<b>405,325</b>	<b>939,395</b>

Through research Florida has been able to increase its understanding of shelter demand. By more accurately identifying demand the State is able to plan for anticipated need thus reducing its hurricane shelter deficit. Through the technologies applied to this effort such as Light Detection And Ranging (LiDAR), and improved SLOSH computer models, the Division is able to more precisely determine which areas are vulnerable to hurricane storm surge. These improved techniques, are the results of the 2010 Statewide Regional Evacuation Study (SRES). In the past, studies were conducted only regionally and sporadically when funding was available. Methodologies varied to meet the needs at the time. The 2010 SRES updated all 11 Regional Planning Council (RPC) Regions simultaneously, and were held to the same methodology.

The application of the data in the new storm tide atlases of the SRES allows local emergency management officials to refine their designated evacuation zones for each storm scenario, increase accuracy in vulnerability assessments which means evacuation areas represent a more precise number of people at risk. Increased accuracy and education combined with a high level of behavioral analyses yielded a better picture of the number of shelter spaces actually needed. Two examples of this application are Broward and Miami-Dade counties. Through its LiDAR project, Broward County was able to reduce its projected number of hurricane evacuees by about 250,000 residents, which reduced anticipated shelter demand by an estimated 37,500 spaces. Miami-Dade County was also able to reduce its evacuation zones through more precise ground surveys. Its new evacuation zones reduce the number of those who will be ordered to evacuate by approximately 395,000, which also reduced anticipated shelter demand by an estimated 59,250 spaces. Hurricane shelter demand estimates have not yet been reduced through adjustments to reflect current census information (i.e., 2010 census) but the projections used in the 2010 SRES estimated the population at 19,979,199 which was over the 2010 census (18,801,310) estimate by 1,177, 889. The population and demand data from the 2010 SRES was incorporated directly into the 2012 Statewide Emergency Shelter Plan as the 2012 and 2017 projections because of the accuracy of numbers and the slightly higher estimate of the population than the census.

Historically, 25 percent or more of the estimated evacuating population were projected to seek safety in public shelters. Many of the post-1998 Hurricane Evacuation Studies, including the 2010 SRES, are now indicating that fewer than 15 percent of the vulnerable population will seek public shelter for a Category 5 hurricane. The 2004 hurricane season provides an example of relatively low public shelter use. Though none of the storms made landfall as a Category 5 hurricane, two storms approached Florida at near Category 5 strength before making landfall as a Category 3 and 4; (Hurricane Ivan and Hurricane Charley respectively). During Hurricane Ivan, an estimated 544,900 persons were under evacuation orders and only 33,472 evacuees were housed in public shelters (6 percent). During Hurricane Charley, although it rapidly intensified only a few hours before landfall, there were an estimated 2.7 million persons under evacuation orders and only 102,094 evacuees were housed in public shelters (3.75 percent). While these examples are not evidence of a decrease in demand they do show that under many circumstances public shelter demand is lower.

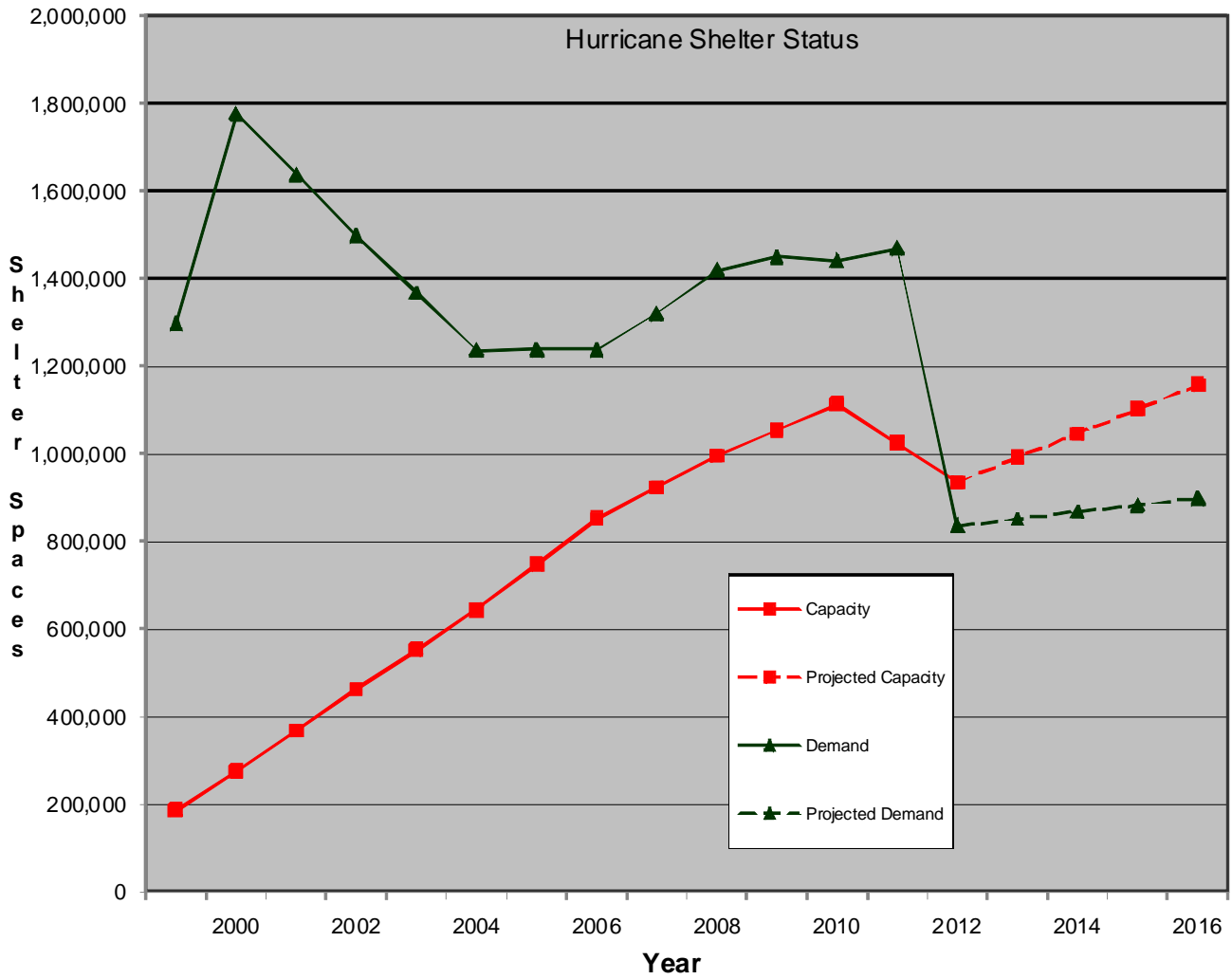
Since publication of the *2000 Statewide Emergency Shelter Plan*, the statewide average estimated demand has fallen from about 24 percent to about eight (8) percent. The practical effect is an apparent reduction in hurricane shelter space demand since 2000, which means federal, state and local agencies do not need to invest public funds to create the additional “bricks-and-mortar” shelter spaces.

The Division has also developed a public information program to compliment the other hurricane evacuation shelter deficit reduction efforts. The Division educates residents on the hazards they face and how to best deal with them. A key issue is whether or not to evacuate and, if so, to where. Education on the hazards and how they affect a community lead to residents making better-informed decisions in a crisis. That effort is being supported by public service announcements, hurricane expositions, training of local responders and volunteers, and through emergency messages during times of crisis. This is expected to be a long-term process that will help to reduce the need for public hurricane evacuation shelter space.

As seen in Table 6-1, since 1999 the Division’s hurricane evacuation shelter survey and retrofit program has identified, created or otherwise documented 459,083 hurricane evacuation shelter spaces that meet ARC 4496 guidelines. Public school new construction programs have created an additional 480,312 hurricane evacuation shelter spaces. Therefore, by the 2012 hurricane season, Florida will have a total of 939,395 shelter spaces that meet ARC 4496 guidelines. The demand for hurricane evacuation shelter space has also been significantly reduced over the past eleven years due to improvements in public information, storm hazard models and more accurate census data. Since 2000, Florida’s deficit of hurricane evacuation shelter space has been eliminated on a statewide aggregate basis. However, three (3) regions remain in a hurricane evacuation shelter space deficit, and a fourth could slip back into a deficit if additional capacity isn’t identified or created over the next five years.

With publication of this Plan, Florida now has 37 counties with demonstrable surpluses of hurricane evacuation shelter space. The counties with surpluses include: Bay, Bradford, Brevard, Broward, Escambia, Gadsden, Gilchrist, Hamilton, Hardee, Hendry, Hillsborough, Holmes, Indian River, Jackson, Jefferson, Lafayette, Lake, Leon, Liberty, Madison, Manatee, Martin, Miami-Dade, Okaloosa, Orange, Osceola, Palm Beach, Polk, St. Johns, St. Lucie, Santa Rosa, Seminole, Suwannee, Taylor, Union, Walton, and Washington.

**Figure 6-1. Projected Hurricane Shelter Deficit Reduction**



## 7.0 CONCLUSIONS

As a result of Hurricane Andrew and the Lewis Commission Report, the State of Florida recognized the necessity of providing safe hurricane evacuation shelter space for its residents during disasters. In support of this goal, the Division, every two years, submits to the Governor and Cabinet, the *Statewide Emergency Shelter Plan*. The Plan identifies the general location and square footage of both general population and SpNS, by RPC region, during the next five (5) years. The Plan also includes information on the availability of shelters that accept pets. The Department of Health assists the Division in determining the estimated need for hurricane evacuation shelter space and the adequacy of facilities to meet the needs of persons with special needs.

The 2012 Plan shows that Florida on a statewide aggregate basis has eliminated the deficit of general population public hurricane evacuation shelter space. However, a deficit of SpNS spaces continues to exist. Since 1995, more than 939,000 hurricane evacuation shelter spaces have been identified, created through retrofitting of existing buildings, or through new construction (e.g., EHPA). As the Division continues to map Florida's coastlines through LiDAR mapping and other improved topographic survey techniques, it is estimated that the public hurricane evacuation shelter demand will continue to be reduced. Since 2004, Florida's statewide aggregate public hurricane evacuation shelter space demand has been reduced to 835,019. In contrast, there was an estimated hurricane evacuation shelter demand of 1,776,606 shelter spaces in 2000.

However, there are still three (3) regions of the state that currently have a deficit of general population hurricane evacuation shelter space, and a fourth that could slide back into a deficit if an inadequate number of spaces are added to the inventory over the next two to five years. Seven (7) regions currently have deficits of SpNS space. Regions that currently have an adequate number of hurricane evacuation shelter spaces will need to maintain the inventory. Over time, current hurricane evacuation shelter buildings may (or will) be decommissioned due to age and other issues; such as, remodeling or reuse that's incompatible with mass care shelter operations, removal or deterioration of window protection products; etc. There may also be changes in storm hazard maps (e.g., SLOSH, national flood insurance, etc.) that could affect their recognition as meeting hurricane safety criteria. Thus, even though the aggregate statewide deficit of space is eliminated in the 2012 Plan, a "maintenance level" of shelter space production will be necessary to avoid falling back into a deficit situation.

Appendix A:  
List of Hurricane Shelters by County, Location and Capacity



**2012 Statewide Emergency Shelter Plan**

**ALACHUA**

Name	Bldg. #	Address	City	Zip	Retrofitted (R) or New Construction (N)	General (G), PSN (P), Pet-Friendly (A)	Total Risk Capacity In People (Meets ARC 4496)	Total Risk Capacity (ft <sup>2</sup> ) (Meets ARC 4496)	Risk Capacity In People (Does not Meet ARC 4496 or Not Yet)	Local Planned Usage (reported capacity)	Funding Source: Local (L), State (S), Federal (F), and Program Name	Comments
Archer community School	6	14533 SW 170 Street	Archer	32618	R	G	211	4,221			1621X-state funds	
Eastside High	Bldg 15	1201 SE 45th Terrace	Gainesville	32641	R	G	673	16,834		501	S-1508-2005	8/31/06-retrofitted
High Springs Community School	Bldg 5	1015 N. Main Street	High Springs	32643		G	0	0	296	296	S-1508-2005	
Joseph Williams ES	7	1245 SE 7ty Avenue	Gainesville	32641	R	G	210	4,196			1621X-state funds	
Kanapaha Middle	Bldg 3	5005 SW 75th Street	Gainesville	32608	R	G	407	9,332		407	S-1508-2005	8/31/06-retrofitted
Kanapaha Middle	Bldg 4	5005 SW 75th Street	Gainesville	32608	R	G	405	8,995		405	S-1508-2005	8/31/06-retrofitted
Oakview Middle -	Bldg 3	701 N Main Street	Newberry	32669	R	G	405	8,935		405	S-1508-2005	8/31/06-retrofitted
Oakview Middle -	Bldg 4	701 N Main Street	Newberry	32669	R	G	405	9,126		405	S-1508-2005	8/31/06-retrofitted
Shell ES	Bldg 2/ Café	21633 SE 65h Avenue	Hawthorne	32640	R	G	0	3,681	214	214	L	
Santa Fe High	Bldg 34	16213 NW US HWY 44	Alachua	32615	N	G	0	0	527	527	L	
Talbot Elementary	Bldg 3	5701 NW 3rd Str	Gainesville	32608	R	G	172	3,789	0	172	S-1508-2005	8/31/06-retrofitted
University of Florida SW Rec	Bldg 316	Building 316	Gainesville	32607	R	G	2,375	47,500	0	0	S-EMPA	
University of Florida	Reitz Union	Building 686	Gainesville	32607	R	G	700	14,000	0	0	S-EMPA	
Waldo community School	6	150 NW Line Avenue	Walod	32694	R	G	362	5,567			1621X-state funds	
<b>TOTALS FOR ALACHUA COUNTY</b>							<b>6,325</b>	<b>136,176</b>	<b>1,655</b>	<b>3,332</b>		
<b>Year 2012</b>	<b>Shelter Capacity In People</b>	<b>Shelter Demand In People</b>	<b>Surplus/Deficit In People</b>	<b>Shelter Capacity (ft2)</b>			<b>Surplus/Deficit (ft2)</b>	<b>Result</b>				
Storm Category 4/5	6,325	13,137	-6,812	136,176			-126,564					
<b>Special Needs Storm Shelters</b>												
Name	Bldg #	Address	City	Zip			SpNS Capacity (spaces @ 60sf)	SpNs Capacity (sf) (meets)	SpNS Capacity (spaces @ 60sf)	Local Planned Usage		Comments
Buchholz High -	Bldg 8 (first floor)	5510 NW 27th Avenue	Gainesville	32606	R	P	231	15,569	0	231	S-1508-2005	8/31/06-retrofitted
Rawlings Elementary	bldg 4/ Café	3500 NE 15th Street	Gainesville	32609	N	P	69	4,145		120		
Westwood Middle -	8, Food Service	3215 NW 15th Avenue	Gainesville	32605	N	P	85	3,403		120		
Alachua ES	Bldg 6	13800 NW 152 Place	Alachua	32615	N	P	115	6,920				online 9/08

2012 Statewide Emergency Shelter Plan

ALACHUA

Year 2012	SpNs Shelter Capacity In Spaces (meets ARC 4496)	SpNs Shelter Demand In Spaces	Surplus/ Deficit In Spaces	SpNs Shelter Capacity (ft2)		Surplus/ Deficit (ft2)	Result			
Storm Category 4/5	500	459	41	30,037		2,497				

**2012 Statewide Emergency Shelter Plan**

**BAKER**

Name	Bldg. #	Address	City	Zip	Retrofitted (R) or New Construction (N)	General (G), PSN (P), Pet Friendly (A)	Total Risk Capacity In People <i>(Meets ARC 4496)</i>	Total Risk Capacity (ft <sup>2</sup> ) <i>(Meets ARC 4496)</i>	Risk Capacity In People <i>(Does not Meet ARC 4496 or Not Yet Surveyed)</i>	Local Planned Usage (reported capacity)	Funding Source: Local (L), State (S), Federal (F), and Program Name	Comments
Baker MS	19	211 E. Jonathan Street	Macclenny	32063	R	G	163	3,260			1621X	
Baker SHS	15	1 Wildcat Drive	Glen Saint Mary	32040	R	G	285	5,712			1621X	
New Macclenny Elementary	B-cafeteria	1 Wildkitten Drive	Macclenny	32063	N	G	306	6,285		306	L	EHPA
New Macclenny ES	A	1 Wildkitten Drive	Macclenny	32063	R	G	296	4,937		296	HB7121	
New Macclenny ES	C	1 Wildkitten Drive	Macclenny	32063	R	G	258	6,467		239	HB7121	
New Macclenny ES	D	1 Wildkitten Drive	Macclenny	32063	R	G	309	6,187		309	HB7121	
New Macclenny ES	E	1 Wildkitten Drive	Macclenny	32063	R	G	309	6,217		309	HB7121	
New Macclenny ES	F	1 Wildkitten Drive	Macclenny	32063	R	G	245	6,127		216	HB7121	
Phoenix Center	Center	523 W. Minnesota Ave	Macclenny	32063	R	G	207	4,140			1621X	
Westside ES	7	One Panther Circle	Glen Saint Mary	32040	R	G	285	5,706			1621X	
<b>Totals for Baker County</b>					<b>0</b>	<b>0</b>	<b>2,663</b>	<b>55,038</b>	<b>0</b>	<b>1,675</b>		
Year 2012	Shelter Capacity In People	Shelter Demand In People	Surplus/Deficit In People	Shelter Capacity (ft2)			Surplus/Deficit (ft2)	Result				
Storm Category 4/5	2,663	2,698	-35	55,038			1,078					
<b>Special Needs Storm Shelters</b>												
Name	Bldg #	Address	City	Zip			SpNS Capacity (spaces @ 60sf) (meets ARC 4496)	SpNs Capacity (sf) (meets ARC 4496)	SpNS Capacity (spaces @ 60sf) (does not meet ARC 4496)	Local Planned Usage (reported capacity)	Funding Source: Local (L), State (S), Federal (F), and Program Name	Comments
TBD							0	0	0			
Year 2012	SpNs Shelter Capacity In Spaces(meets ARC 4496)	SpNs Shelter Demand In Spaces	Surplus/Deficit In Spaces	SpNs Shelter Capacity (ft2)			Surplus/Deficit (ft2)	Result				
Storm Category 4/5	0	75	-75	0			-4,500					

**2012 Statewide Emergency Shelter Plan**

**BAY**

Name	Bldg. #	Address	City	Zip	Retrofitted (R) or New Construction (N)	General (G), PSN (P), Pet Friendly (A)	Total Risk Capacity In People (Meets ARC 4496)	Total Risk Capacity (ft <sup>2</sup> ) (Meets ARC 4496)	Risk Capacity In People (Does not Meet ARC 4496 or Not Yet Surveyed)	Local Planned Usage (capacity reported)	Funding Source: Local (L), State (S), Federal (F), and Program Name	Comments
Bay High School	7 (Dining)	1204 Harrison Avenue	Panama City	32405	R	G,A	907	13,609		967		shuttered?/door braced?
Bozeman Learning Center	1	13410 Highway 77	Southport	32409	R	G,A	267	5,340		267		
Bozeman Learning Center	2	13410 Highway 77	Southport	32409	R	G,A	436	6,541		587	HMGP	
Bozeman Learning Center	3	13410 Highway 77	Southport	32409	R	G,A	526	7,894		641		
Bozeman Learning Center	4	13410 Highway 77	Southport	32409	R	G,A	580	9,401		580	HMGP	
Bozeman Learning Center	5	13410 Highway 77	Southport	32409	R	G,A	686	11,518		686	HMGP	
Bozeman Learning Center	6	13410 Highway 77	Southport	32409	R	G,A	319	4,791		604	HMGP	
Bozeman Learning Center	7	13410 Highway 77	Southport	32409	R	G,A	510	7,647		826	L	waived by county
Cedar Grove ES	12	2826 East 15th Street	Panama City	32405	R	G,A	306	4,865		306	HMGP	
Cedar Grove ES	13	2826 East 15th Street	Panama City	32405	R	G,A	142	2,137		206	HMGP	
Everitt Ms	9 (locker rm additions)	608 School Avenue	Panama City	32401	R	G,A	206	4,127			HMGP	Locker Rm additions
Fairgrounds	25		Panama City		R	G,A	1,671	33,420				HB7121
Haney Votech	24		Panama City		R	G,A	300	6,000				HB7121
Jinks JrHS	6	600 West 11th Street	Panama City	32401	R	G,A	125	2,769		125	HMGP	
Jinks JrHS	10	600 West 11th Street	Panama City	32401	R	G,A	76	1,836		76	HMGP	
Merriam-Cherry St. ES	11	1125 Cherry Street	Panama City	32401	N	G,A	253	5,054			L	EHPA-per county-2007
Merritt Brown Elementary School	4 (first floor)	5601 Merritt Brown Road	Panama City	32404	R	G,A	877	17,538			HMGP	two-story
MK Lewis center	5	1527 Lincoln Avenue	Panama City	32405	R	G,A	55	1,100		55	L	waived by county
Moore Elementary School	10 or 2	1900 Michigan Avenue	Panama City	32405	R	G,A	168	3,357			HMGP	
Moore Elementary School	11 or 3	1900 Michigan Avenue	Panama City	32405	R	G,A	483	9,661			HMGP	
Moore Elementary School	12 or 4	1900 Michigan Avenue	Panama City	32405	R	G,A	393	7,862			HMGP	
Moore Elementary School	13 or 5	1900 Michigan Avenue	Panama City	32405	R	G,A	46	925			HMGP	
Mowat MS	11	1903 Hwy 390	Panama City	33444	R	G,A	139	2,782		139	HMGP	
New Horizons Learning C	2	3100 Minnesota Ave	Panama City	32405	N	G,A	222	4,443			L	EHPA-per Ehpa list -2009
Oakland Terrace ES	9	2010 W. 12th Street	Panama City	32401	N	G,A	0	0			L	not- per EHPA list-2009
Oakland Terrace ES	13	2010 West 12th Street	Panama City	32401	R	G,A	224	3,365		294	HMGP	
Oakland Terrace ES	14	2010 West 12th Street	Panama City	32401	R	G,A	258	4,159		258	HMGP	
Parker ES	2	640 S. Hwy. 22A	Panama City	32404	N	G,A	180	3,600			L	per EHPA list -2009
Pattersen ES	2	1025 Redwood Avenue	Panama City	32401	R	G,A	0	0	0		F	HB7121
Pattersen ES	16	1025 Redwood Avenue	Panama City	32401	R	G,A	265	5,294			F	HB7121
rosenwald JrHS	13	1310 East 11th Street	Panama City	32401	R	G,A	202	3,493		202		
Rutherford High School	2 (1st floor Hallway and Media/Classrooms)	1000 School Avenue	Panama City	32401	R	G,A	237	4,740		237	HMGP	
Rutherford High School	12	1000 School Avenue	Springfield	32401	R	G,A	0	0	209		F	HB7121
Rutherford High School	13	1000 School Avenue	Springfield	32401	R	G,A	552	11,031			F	HB7121
Rutherford High School	14	1000 School Avenue	Springfield	32401	R	G,A	0	0	503		F	HB7121
Rutherford High School	15	1000 School Avenue	Springfield	32401	R	G,A	0	0	378		F	HB7121
Springfield Elementary School	14	520 School Avenue	Panama City	32401	R	G,A	245	4,072		245	HMGP	
Springfield Elementary School	15	520 School Avenue	Panama City	32401	R	G,A	250	3,746	0	255	HMGP	
Suffside Middle School	4	300 Nautilus Street	Panama City Beach	32407	R	G,A	898	17,965			HMGP	
Surfside Middle School	5	300 Nautilus Street	Panama City Beach	32407	R	G,A	231	4,619			HMGP	
T. Smith Elementary School	1	5044 Tommy Smith Way	Panama City	32404	R	G,A	235	4,708			HMGP	
T. Smith Elementary School	2	5044 Tommy Smith Way	Panama City	32404	R	G,A	400	8,007			HMGP	
T. Smith Elementary School	3	5044 Tommy Smith Way	Panama City	32404	R	G,A	426	8,515			HMGP	
T. Smith Elementary School	4	5044 Tommy Smith Way	Panama City	32404	R	G,A	438	8,764			HMGP	
Waller Elementary School	1	11332 Highway 388	Fountain	32466	R	G,A	0	0	438		F	HB7121
Waller Elementary School	3	11332 Hwy 338	Youngstown	32466	R	G,A	82	1,638			L	
Waller Elementary School	4	11332 Hwy 338	Youngstown	32466	R	G,A	207	4,141			L	
Waller Elementary School	5	11332 Highway 388	Fountain	32466	R	G,A	288	5,757			F	HB7121
<b>TOTALS FOR BAY COUNTY</b>							<b>15,311</b>	<b>282,231</b>	<b>1,465</b>	<b>7,556</b>		<b>0</b>

**2012 Statewide Emergency Shelter Plan**

**BAY**

Year 2012	Shelter Capacity In People	Shelter Demand In People	Surplus/ Deficit In People	Shelter Capacity (ft2)			Surplus/ Deficit (ft2)	Result				
Storm Category 4/5	15,311	7,328	7,983	282,231			135,671					
Special Needs Storm Shelters												
Name	Bldg #	Address	City	Zip			SpNS Capacity (spaces @ 60sf) (meets ARC 4496)	SpNs Capacity (sf) (meets ARC 4496)	SpNS Capacity (spaces @ 60sf) (does not meet ARC 4496)	Local Planned Usage (capacity reported)	Funding Source: Local (L), State (S), Federal (F), and Program Name	Comments
Bozeman Learning Center K-7	Cafeteria 9	13410 Highway 77	Southport	32409	N	P,A	110	8,277		108	EHPA	EHPA
Bozeman Learning Center K-8	8 (Gym)	13410 Highway 77	Southport	32409	N	P,A	191	11,466			HMGP	EHPA
Haney Votech	1-Admin/3-Story (Old 9)	3016 Hwy 77	Panama City	32405	N	P,A	594	28,250		594	1588-2006	No official capacity
Year 2012	SpNs Shelter Capacity In Spaces (meets ARC 4496)	SpNs Shelter Demand In Spaces	Surplus/ Deficit In Spaces	SpNs Shelter Capacity (ft2)			Surplus/ Deficit (ft2)	Result				
Storm Category 4/5	895	337	558	8,277			-11,943					

**2012 Statewide Emergency Shelter Plan**

**BRADFORD**

Name	Bldg. #	Address	City	Zip	Retrofitted (R) or New Construction (N)	General (G), PSN (P), Pet - Friendly (A)	Total Risk Capacity In People <i>(Meets ARC 4496)</i>	Total Risk Capacity (ft <sup>2</sup> ) <i>(Meets ARC 4496)</i>	Risk Capacity In People <i>(Does not Meet ARC 4496 or Not Yet Surveyed)</i>	Local Planned Usage (capacity reported)	Funding Source: Local (L), State (S), Federal (F), and Program Name	Comments
Bradford MS	6	58 North Orange Street	Starke	32092	R	G	52	1,040			1621X	
Bradford MS	7	SR 221 and CR 18	Hampton	32044	R	G	218	4,956			1621X	
Hampton ES	5	SR 221 and CR 18	Hampton	32044	R	G	124	1,900			1621X	
Lawtey Elementary	6	N Park St and US HWY 301	Lawtey	32058	R	G	173	3,258		173	L, S, HMGP	
Starke Elementary School	2	1000 Weldon St	Hampton	32044	R	G	363	5,975		363	L, S, HMGP	
Starke Elementary School	5	1000 Weldon St	Hampton	32044	R	G	238	3,937		307	L, S, HMGP	
Starke Elementary School	6	1000 Weldon St	Hampton	32044	R	G	313	4,700		352	L, S, HMGP	
<b>TOTALS FOR BRADFORD COUNTY</b>							<b>1,481</b>	<b>25,766</b>	<b>0</b>	<b>1,195</b>		<b>0</b>
Year 2012	Shelter Capacity In People	Shelter Demand In People	Surplus/ Deficit In People	Shelter Capacity (ft2)			Surplus/ Deficit (ft2)	Result				
Storm Category 4/5	1,481	1,282	199	25,766			126					
<b>Special Needs Storm Shelters</b>												
Name	Bldg #	Address	City	Zip			SpNS Capacity (spaces @ 60sf) (meets ARC 4496)	SpNs Capacity (sf) (meets ARC 4496)	SpNS Capacity (spaces @ 60sf) (does not meet ARC 4496)	Local Planned Usage (capacity reported)	Funding Source: Local (L), State (S), Federal (F), and Program Name	Comments
South Side Elementary School	10	823 Stanbury St	Starke	32091		P,A	53	3,223		131 by Gen Pop		Emergency power by generator but no Hvac
Starke Elementary School	4	1000 Weldon St	Starke	32044		P	66	3,950				per State Study
Starke ES	3	1000 Weldon St	Starke	32044		P	95	5,712		51		
Year 2012	SpNs Shelter Capacity In Spaces (meets ARC 4496)	SpNs Shelter Demand In Spaces	Surplus/ Deficit In Spaces	SpNs Shelter Capacity (ft2)			Surplus/ Deficit (ft2)	Result				
Storm Category 4/5	214	194	20	3,223			-8,417					

2012 Statewide Emergency Shelter Plan

BREVARD												
Name	Bldg. #	Address	City	Zip	Retrofitted (R) or New Construction (N)	General (G), PSN (P), Pet-Friendly (A)	Total Risk Capacity In People (Meets ARC 4496)	Total Risk Capacity (ft <sup>2</sup> ) (Meets ARC 4496)	Risk Capacity In People (Does not Meet ARC 4496, or Not Yet Surveyed)	Local Planned Usage (capacity reported)	Funding Source: Local (L), State (S), Federal (F), and Program Name	Comments
Anderson Elementary School	2 (3,4,5)	3011 S Fiske Boulevard	Rockledge	32955	R	G	744.00	15,803.00		744	F, S	updated FISH
Apollo Elementary School	2,3,4	3085 Knox McCrea Drive	Titusville	32780	R	G	752.00	752.00		752	F, S	updated FISH
Astronaut High School	400wing & 800 wing (1994 areas)	800 War Eagle Boulevard	Titusville	32796	R	G	264.00	6,594.00		75	S-1118A	updated FISH
Atlantis Elementary	1 thru 6	7300 Briggs Avenue	Port St. John	32927	R	G	1,295.00	26,134.00		1,295	HMGP	updated FISH
Bayside High School	1	1901 DeGroot	Palm Bay	32908	R	G	96.00	1,911.00				updated FISH
Bayside High School	2	1901 DeGroot	Palm Bay	32908	R	G	128.00	2,552.00				updated FISH
Bayside High School	3	1901 DeGroot	Palm Bay	32908	R	G	279.00	5,584.00				updated FISH
Bayside High School	5	1901 DeGroot	Palm Bay	32908	R	G	268.00	5,358.00				updated FISH
Bayside High School	6	1901 DeGroot	Palm Bay	32908	R	G	1,920.00	38,393.00				updated FISH
Bayside High School	7	1902 DeGroot	Palm Bay	32909	R	G	981.00	19,612.00				updated FISH
Bayside High School	campus	1901 DeGroot	Palm Bay	32908	N	G	0.00	0.00		2,246		updated FISH
Brevard Community College - Palm Bay	5	250 Community college Pkwy	Palm Bay	32908	N	G	0.00	0.00				school does not meet ARC 4496
Brevard Community College - Cocoa	3	1519 Clearlake Drive	Cocoa	32922	R	G	812.00	16,240.00		812		increased lab spaces at college decreased capacity
Brevard Community College - Cocoa-Allied Health	Bldg 20	1519 Clearlake Drive	Cocoa	32922	R	G	675.00	13,500.00		675	s-1118A	
Brevard Community College - Melbourne	1 (OCC)	3865 N Wickham Road	Melbourne	32935	R	G	600.00	12,000.00		600	HMGP	increased lab spaces at college decreased capacity
Brevard Community College - Melbourne	10	3865 N Wickham Road	Melbourne	32935	R	G	175.00	3,500.00		175	HMGP	increased lab spaces at college decreased capacity
Brevard Community College - Melbourne	5	3865 N Wickham Road	Melbourne	32935	R	G	0.00	0.00				dropped
Cambridge Elementary School	15	2000 Cambridge Drive	Cocoa	32922	N	G	207.00	3,471.00		207	L	per ehpa list
Cambridge Elementary School	16	2000 Cambridge Drive	Cocoa	32922	N	G	206.00	3,459.00		206		per ehpa list
Central Middle School	1 thru 6	2600 Wingate Boulevard	W Melbourne	32904	R	G	1,539.00	38,477.00		807	F, S	
Central Reference Library	1	308 FORREST AVE	Cocoa	32922	R	G	1,088.00	27,200.00		750	HMGP	Orig- 2000 spaces
City of Palm Bay	EOC		Palm Bay	32908	N	G	150.00	3,000.00		113	s-1543A-2002	
Discovery Elementary School	1	1275 Glendale Avenue NW	Palm Bay	32905	R	G	204.00	4,073.00		300	HMGP	Orig- 1500 spaces
Discovery Elementary School	2	1275 Glendale Avenue NW	Palm Bay	32905	R	G	188.00	3,757.00		1,425	HMGP	bldg 1-6 totalled only; updated FISH
Discovery Elementary School	3	1275 Glendale Avenue NW	Palm Bay	32905	R	G	287.00	5,741.00			HMGP	updated FISH
Discovery Elementary School	4	1275 Glendale Avenue NW	Palm Bay	32905	R	G	304.00	6,087.00			HMGP	updated FISH
Discovery Elementary School	5	1275 Glendale Avenue NW	Palm Bay	32905	R	G	377.00	7,542.00			HMGP	updated FISH
Discovery Elementary School	6	1275 Glendale Avenue NW	Palm Bay	32905	R	G	238.00	4,765.00			HMGP	updated FISH
Discovery Elementary School	10	1275 Glendale Avenue NW	Palm Bay	32905	N	G	211.00	4,218.00			L	EHPA; Updated FISH
Eau Gallie High School	22-Aud	1400 Commodore Blvd	Melbourne	32935	R	G	677.00	13,531.00			F, S	updated FISH
Eau Gallie High School	37-Science	1400 Commodore Blvd	Melbourne	32935	R	G	0.00	0.00		497	not retrofitted	updated FISH
Endeavor Elementary School	13	905 Pineda Street	Cocoa	32922	N	G	450.00	7,232.00		450	L	per ehpa list
Enterprise Elementary School	1 thru 6	7000 Enterprise Road	Port St. John	32927	R	G	1,370.00	28,669.00		1,370	HMGP	
Heritage High School	3	2353 West Malabar Rd	Palm Bay	32907	N	G,A	361.00	7,211.00		1,174	total 3&7	per ehpa list
Heritage High School	7	2353 West Malabar Rd	Palm Bay	32907	N	G	1,038.00	20,769.00				per ehpa list
Imperial Estates Elementary School	5 thru 8	5525 Kathy Drive	Titusville	32780	R	G	720.00	14,028.00		720	F, S	
John F. Turner Sr. Elementary	2	3175 Jupiter Blvd SE	Palm Bay	32909	N	G	251.00	5,027.00		450	total 2&3	per ehpa list
John F. Turner Sr. Elementary	3	3175 Jupiter Blvd SE	Palm Bay	32909	N	G	224.00	4,483.00				per ehpa list
Jupiter Elementary School	1 thru 6	950 Tupelo Road SW	Palm Bay	32908	R	G	1,258.00	25,982.00		1,258	HMGP	
Long Leaf Elementary School	1	4290 N Wickham Road	Melbourne	32935	R	G	1,549.00	38,727.00		1,284	F, S	updated FISH
Manatee Elementary School	1	3425 Solerno Boulevard	Viera	32940	N	G	1,729.00	43,237.00		1,427	L	per ehpa list; updated FISH
Meadowlane Elementary School	1 thru 6	2800 Wingate Boulevard	Melbourne	32904	R	G	1,284.00	24,563.00		1,284	total 1-6	
Meadowlane Intermediate Elementary School	1-2nd floor	2700 Wingate Blvd	Melbourne	32904	N	G	563.00	14,080.00		471	L	EhPA 1st Floor SNS and 2nd Flor GP
Melbourne High School	1 & 8	74 Bulldog Way	Melbourne	32901	R	G	0.00	0.00		599	F, S	updated FISH Total for 1 & 8 2.74' slosh
Melbourne HS	18	74 Bulldog Blvd	Melbourne	32901	N	G	0.00	0.00		730	L	per ehpa list; updated FISH 2.74' slosh
Mims Elementary School	13 (new wing)	2582 US 1	Mims	32754	N	G	338.00	7,227.00		338	L	
Palm Bay Elementary	8	1200 ALLAMANDA ROAD NE	PALM BAY	32905-4299	N	G	0.00	0.00				per ehpa list; updated FISH, 2.8' Slosh
Palm Bay Senior High	8	101 Pirate Lane	Melbourne	32901	N	G	227.00	4,536.00				per ehpa list; updated FISH
Palm Bay Regional Park	1	1951 NW Malabar Rd	Palm Bay	32907	N	G	509.00	10,180.00		509		Feb 09 completed-per county.
Pinewood Elementary School	4	3654 Lionel Road	Mims	32754	R	G	381.00	9,518.00		360	F, S	updated FISH
Port St. John Community Center	Center	6650 Corto Rd	Port St. John	32927	R	G,A	300.00	4,962.00		300	HMGP	Orig - 600
Riviera Elementary School	1 thru 6	351 Riviera Drive NE	Palm Bay	32905	R	G	1,106.00	27,650.00		981	HMGP	updated FISH
Rockledge High School	1,2,8,9	220 Raider Drive	Rockledge	32955	R	G	504.00	12,603.00		490	HMGP	Orig- 500 spaces
Roy Allen ES	6	2601 Fountainhead	Melbourne	32909	N	G	1,235.00	30,871.00		1,165	L	per ehpa list; updated FISH
Sherwood Elementary School	1	2541 Post Road	Melbourne	32935	R	P	1,511.00	37,780.00		1,246	F, S	updated FISH
South Mainland (Micco)	Gym	3700 Allen Avenue	Micco	32976	N	P	0.00	0.00		300	HMGP	Orig- 650
South Mainland (Micco)	Main (1)	3700 Allen Avenue	Micco	32976	R	G	173.00	3,000.00		173	HMGP	updated FISH
Southwest Junior High School		451 Eldron Boulevard SE	Palm Bay	32909		G	0.00	0.00		750		
Space Coast Jr/Sr HS	11 (Music)	6150 Banyan Street	Port St. John	32927	R,N	G	308.00	6,150.00		300	F, S	EHPA
Space Coast Jr/Sr HS	1st floor (100-400)	6150 Banyan Street	Port St. John	32927	R	G	675.00	12,000.00		675	F, S	updated FISH
Space Coast Jr/Sr HS	2nd floor (500-800)	6150 Banyan Street	Port St. John	32927	R	G	600.00	12,000.00		600	S-1588-2006	updated FISH

**2012 Statewide Emergency Shelter Plan**

<b>BREVARD</b>												
Suntree Elementary School	1 thru 6	900 Pinehurst Avenue	Melbourne	32940	R	G	1,061.00	28,534.00		907	HMGP	updated FISH
Titusville High	2	150 Terrier Trail	Titusville	32780	N	G	0.00	0.00				in cat 3 zone
Viera Regional Park	1	2300 Judge Fran Jamieson Way	Viera	32940	N	G,S	0.00	0.00		300		
Viera High School	2	6103 Stadium Parkway	Viera	32940	N	G	1,088.00	21,752.00		1,100	tot 2&6	per ehpa list
Viera High School	6	6103 Stadium Parkway	Viera	32940	N	G	627.00	12,549.00				per ehpa list
Walter Butler Community Center	1	Ferguson Lane	Sharpes	32959	N	G	0.00	0.00		509		
Westside Elementary School	1	2175 DeGroot Road SW	Palm Bay	32908	R	G	1,526.00	38,160.00		1,313	S-1118A	updated FISH
Westside Elementary School	4 (2005)	2175 DeGroot Road SW	Palm Bay	32908	R	G	263.00	5,267.00				updated FISH
<b>TOTALS FOR BREVARD COUNTY</b>							<b>37,894</b>	<b>810,001</b>	<b>0</b>	<b>35,212</b>		
<b>Year 2012</b>	<b>Shelter Capacity In People</b>	<b>Shelter Demand In People</b>	<b>Surplus/Deficit In People</b>	<b>Shelter Capacity (ft2)</b>			<b>Surplus/Deficit (ft2)</b>	<b>Result</b>				
Storm Category 4/5	37,894	32,586	5,308	810,001			158,281					
<b>Special Needs Storm Shelters</b>												
<b>Name</b>	<b>Bldg #</b>	<b>Address</b>	<b>City</b>	<b>Zip</b>			<b>SpNS Capacity (spaces @ 60sf) (meets ARC 4496)</b>	<b>SpNs Capacity (sf) (meets ARC 4496)</b>	<b>SpNS Capacity (spaces @ 60sf) (does not meet ARC 4496)</b>	<b>Local Planned Usage (capacity reported)</b>	<b>Funding Source: Local (L), State (S), Federal (F), and Program Name</b>	<b>Comments</b>
Oak Park ES (Prio 4)	2,5,6,7,8	3395 Dairy Road	Titusville	32796	R	P	300	11,981		333		
Quest ES	1	8751 Trafford Drive	Melbourne	32940	N	P	531	42,509		375		EHPA
Ralph Williams ES (pri 1)	Main	1700 Clubhouse Drive	Rockledge	32955	N	P	474	37,918		375		
South Mainland (Micco)	Gym	3700 Allen Avenue	Micco	32976	R	P	400	24,000		400		Generator completed jan1, 2008
Sunrise ES	Main	1651 Mara Loma Blvd SE	Palm Bay	32909	N	P	375	21,960		375		EHPA
Meadowlane Intermediate Elementary	1-1st floor	2700 Wingate Blvd	Melbourne	32904	N	P	540	32,405				EHPA
<b>Year 2012</b>	<b>SpNs Shelter Capacity In Spaces (meets ARC 4496)</b>	<b>SpNs Shelter Demand In Spaces</b>	<b>Surplus/Deficit In Spaces</b>	<b>SpNs Shelter Capacity (ft2)</b>			<b>Surplus/Deficit (ft2)</b>	<b>Result</b>				
Storm Category 4/5	2,620	98	2,522	157,200			151,320					

updated 11/01/11



2012 Statewide Emergency Shelter Plan

BROWARD												
Name	Bldg. #	Address	City	Zip	Retrofitted (R) or New Construction (N)	General (G), PSN (P), Pet-Friendly (A)	Total Risk Capacity In People (Meets ARC 4496)	Total Risk Capacity (ft <sup>2</sup> ) (Meets ARC 4496)	Risk Capacity In People (Does not Meet ARC 4496 or Not Yet Surveyed)	Local Planned Usage (reported capacity)	Funding Source: Local (L), State (S), Federal (F), and Program Name	Comments
Arthur Ashe MS	1 or 3701	1701 NW 23 Avenue	Ft. Lauderdale	33311	N	G	1,200	22,642		1,200	L	primary;Updated FISH
Challenger Elementary	1 or 3771	5700 NW 94	Tamarac	33321	N	Alt Arc	1,928	48,207		800	L	primary, responders;updated Fish
Coconut Creek High School		1400 NW 44th Avenue	Coconut Creek	33066		G	0	0	1,800		L	
Coconut Palm Elementary	1	13601 Monarch lakes Blvd	Miramar	33027	N	G	1,839	45,982		800	L	secondary;updated FISH
Coral Cove Elementary		5100 SW 148 Avenue	Miramar	33027		G	800	16,000	1,545	800	L	tertiary;updated FISH
Coral Glades High School	3	Sports Plex Drive	Coral Springs	33065	N	G	1,800	33,916		1,800	L	updated FISH
Dolphin Bay ES		16450 Miramar Parkway	Miramar	33027	N	G	815	16,300	1,545		L	Updated FISH
Everglades Elementary	1 or 2942	2900 Bonaventure Blvd	Weston	33331	N	G	1,830	45,745		800	L	secondary;updated FISH
Everglades High School	2 or 3731	17100 SW 48th Ct	Miramar	33027	N	G	1,817	45,434		1,800	L	primary;Updated FISH
Falcon Cove Middle School	3 or 2431	4251 Bonaventure Blvd	Weston	33332	N	G	1,200	24,508		1,200	L	primary;Updated FISH
Floranda Elementary School	851	5251 NE 14th Way	Ft. Lauderdale	33334	N&R	G	800	16,000	1,589	800	L	tertiary-partial ehpa
Fox Trail Elementary School	1 or 3531	1250 Nob Hill Road	Davie	33324	N	G	1,911	47,778		800	L	primary;Updated FISH
Gator Run Elementary	1 or 3641	1101 Arvida Parkway	Weston	33327	N	G	1,830	45,741		800	L	secondary;updated FISH
Hallandale Elementary	3 or 131	1000 SW 8th St	Hallandale	33009	N	G	1,310	32,746		300	L	tertiary;updated FISH
Lakeside Elementary School	1 or 3591	900 NW 136 Avenue	Pembroke Pines	33026	N	G	1,868	46,697		800	L	secondary;updated FISH
Liberty Elementary	1 or 3821	2450 Banks	Margate	33063	N	G	1,843	46,067		800	L	tertiary;updated FISH
Lyons Creek Middle School	1 or 3101	4333 Sol Press Blvd	Coconut Creek	33073	N	G	2,158	53,951		1,200	L	primary;Updated FISH
Manatee Bay Elementary	1 or 3831	19200 SW 36	Weston	33331		G	1,837	45,934		800	L	tertiary;updated FISH
Millenium MS	2&33	5803 NW 94th Avenue	Tamarac	33321	N	G,A	500	10,000		500	L	primary, Pet friendly-not ehpa;Existing Data 2010 SESP
Monarch High School	2 or 3541	5050 Wiles Rd	Coconut Creek	33063	N	G	1,452	21,782		1,800	L	primary;Updated FISH
New Renaissance Middle	3 or 3671	10701 Miramar	Miramar	33025	N	G	1,200	23,623		1,200	L	Updated FISH
Orange Brook ES		715 S. 46th Avenue	Hollywood	33021	N	G	815	16,300	1,552	800	L	tertiary;updated FISH
Panther Run Elementary School	1 or 3571	801 NW 172 Avenue	Pembroke Pines	33328	N	G	1,915	47,887		800	L	tertiary;updated FISH
Park Lakes Elementary	1 or 3761	3925 N. State	Lauderdale Lakes	33309	N	G	1,907	47,676		800	L	primary;Updated FISH
Park Trails Elementary	1	10700 Trails End	Parkland	33076	N	G	1,940	48,509		800	L	tertiary;updated FISH
Parkside Elementary School	1 or 3631	10257 NW 29th Street	Coral Springs	33065	N	G	0	0		800	L	secondary;updated FISH 15.6' per stolsh
Pines MS		200 NW Douglas Road	Pembroke Pines	33024	N	G	1,210	24,200	3,890	1,200	L	tertiary;updated FISH
Plantation Elementary	1 or 941	651 NW 42nd Avenue	Ft. Lauderdale	N/A	N	G	1,907	47,676		800	L	primary;Updated FISH
Pompano Beach High School	181	1400 NE 6th St	Pompano Beach	33060	N	G	1,800	36,000		1,800	L	primary;Existing 2010 SESP Data
Rock Island Elementary		2350 NW 19 Street	Ft. Lauderdale	33311	N	G	800	16,000	845	800	L	primary;Updated FISH
Silver Lakes Elementary School	1 or 3371	2300 SW 173 Avenue	Miramar	33027	N	G	1,925	48,118		800	L	tertiary;updated FISH
Silver Palms Elementary School	1 or 3371	1209 NW 155th Avenue	Pembroke Pines	33029	N	G	1,863	46,566		800	L	secondary;updated FISH
Silver Shores Elementary	1 or 3581	1701 SW 160	Miramar	33027	N	G	1,836	45,892		800	L	tertiary;updated FISH
Silver Trail Middle School	2 or 3331	18300 Sheridan Street	Pembroke Pines	33331	N	G	1,200	25,014		1,200	L	primary;Updated FISH
Sunset Lakes Elementary	1 or 3661	18400 SW 25	Miramar	33027	N	G	1,843	46,067		800	L	tertiary;updated FISH
Tradewinds Elementary	1 or 3481	5400 Johnson Road	Coconut Creek	33073	N	G	1,869	46,730		800	L	secondary;updated FISH
Watkins Elementary School	1 or 511	3520 NW 52nd Avenue	Hollywood	33023	N	G	1,911	47,778		800	L	primary;Updated FISH
West Broward High School	3	500 NW 209th Avenue	Pembroke Pines	33029	N	G	1,677	25,155		1,800	L	primary;Updated FISH
<b>TOTALS FOR BROWARD COUNTY</b>							<b>56,356</b>	<b>1,304,621</b>	<b>12,766</b>	<b>35,400</b>		<b>0</b>
<b>Year 2012</b>	<b>Shelter Capacity In People</b>	<b>Shelter Demand In People</b>	<b>Surplus/ Deficit In People</b>	<b>Shelter Capacity (ft2)</b>			<b>Surplus/ Deficit (ft2)</b>	<b>Result</b>				
Storm Category 4/5	56,356	25,907	30,449	1,304,621			786,481					
<b>Special Needs Storm Shelters</b>												
<b>Name</b>	<b>Bldg #</b>	<b>Address</b>	<b>City</b>	<b>Zip</b>			<b>SpNS Capacity (spaces @ 60sf) (meets ARC 4496)</b>	<b>SpNs Capacity (sf) (meets ARC 4496)</b>	<b>SpNS Capacity (spaces @ 60sf) (does not meet ARC 4496)</b>	<b>local planned usage</b>	<b>Funding Source: Local (L), State (S), Federal (F), and Program Name</b>	<b>Comments</b>

**2012 Statewide Emergency Shelter Plan**

<b>BROWARD</b>												
Indian Ridge MS	2 or 3471 (471)	1355 Nob Hill Road	Davie	33324	N	P	313	25,014		250		* Indian Ridge MS Emergency Powered HVAC-Not operation yet.
McNichols MS	3 (423)	1602 S. 27th Ave.	Hollywood	33020	N	P	302	24,184		250		
New River MS	3-café-gym- classrms	3100 Riverland Rd	Ft. Lauderdale	33312	N	P	296	23,650		250		
Sunset Learning Cntr (Sunset School)	1 (533)	3775 SW 16th St.	Ft. Lauderdale	33312	N	P	368	29,445		25		
WestGlades MS	3	11000 Holmb	Parkland	33026	N	P	295	23,623		25		*West Glades MS Emergency Powered HVAC- Has 5 Portable A/C Units for Cafetorium areas of EHPA
<b>Year 2012</b>	<b>SpNs Shelter Capacity In Spaces (meets ARC 4496)</b>	<b>SpNs Shelter Demand In Spaces</b>	<b>Surplus/ Deficit In Spaces</b>	<b>SpNs Shelter Capacity (ft2)</b>			<b>Surplus/ Deficit (ft2)</b>		<b>Result</b>			
Storm Category 4/5	1,574	1,277	297	94,440			17,820					

**2012 Statewide Emergency Shelter Plan**

**CALHOUN**

Name	Bldg. #	Address	City	Zip	Retrofitted (R) or New Construction (N)	General (G), PSN (P), Pet-Friendly (A)	Total Risk Capacity In People (Meets ARC 4496)	Total Risk Capacity (ft <sup>2</sup> ) (Meets ARC 4496)	Risk Capacity In People (Does not Meet ARC 4496 or Not Yet Surveyed)	Local Planne Usage (reported capacity)	Funding Source: Local (L), State (S), Federal (F), and Program Name	Comments
Altha High School		Main Street	Altha	32421			0	0				
Carr Elementray/Middle School		Highway 73 North	Altha	32430			0	0				
Blountstown Elementray School		Fuller Warren Drive	Blountstown	32424			0	0				
Blountstown Middle School		611 Mathaw Drive	Blountstown	32424			0	0				
Blountstown High School		614 North Main Street	Blountstown	32424			0	0				
Blountstown High School (NEW)	4 Food Service	18597 NE SR 69	Blountstown	32424	N	G	172	3,443				
<b>TOTALS FOR CALHOUN COUNTY</b>							<b>172</b>	<b>3,443</b>		<b>0</b>		<b>0</b>

Year 2012	Shelter Capacity In People	Shelter Demand In People	Surplus/ Deficit In People	Shelter Capacity (ft <sup>2</sup> )	Surplus/ Deficit (ft <sup>2</sup> )	Result
Storm Category 4/5	172	1,060	-888	3,443	-17,757	

**Special Needs Storm Shelters**

Name	Bldg #	Address	City	Zip	SpNS Capacity (spaces @ 60sf) (meets ARC 4496)	SpNS Capacity (sf) (meets ARC 4496)	SpNS Capacity (spaces @ 60sf) (does not meet ARC 4496)	Local Planne Usage (reported capacity)	Funding Source: Local (L), State (S), Federal (F), and Program Name	Comments
<b>Uses Regional Shelter</b>										

Year 2012	SpNs Shelter Capacity In Spaces (meets ARC 4496)	SpNs Shelter Demand In Spaces	Surplus/ Deficit In Spaces	SpNs Shelter Capacity (ft <sup>2</sup> )	Surplus/ Deficit (ft <sup>2</sup> )	Result
Storm Category 4/5	0	100	-100	0	-6,000	

2012 Statewide Emergency Shelter Plan

**CHARLOTTE**

Name	Bldg. #	Address	City	Zip	Retrofitted (R) or New Construction (N)	General (G), PSN (P), Pet-Friendly (A)	Total Risk Capacity In People (Meets ARC 4496)	Total Risk Capacity (ft <sup>2</sup> ) (Meets ARC 4496)	Risk Capacity In People (Does not Meet ARC 4496 or Not Yet Surveyed)	Local Planned usage (capacity reported)	Funding Source: Local (L), State (S), Federal (F), and Program Name	Comments
Liberty ES	café & hallways	370 Atwater Street	Port Charlotte	33952	R	G	0	0	0	500	L	exiting storm only 15.1' SLOSH
Port Charlotte MS	café & hallways	23000 Midway Blvd NE	Port Charlotte	39952	R	G	0	0	0	1,000	L	exiting storm only 15.7' SLOSH
Kingsway ES	1st floor	23300 Quasar Blvd	Port Charlotte	33980	R	G	0	0	0	2,000	S-1467-2004	exiting storm only 8.43' SLOSH
<b>TOTALS FOR CHARLOTTE COUNTY</b>							<b>0</b>	<b>0</b>	<b>0</b>	<b>3,500</b>		<b>0</b>

Year 2012	Shelter Capacity In People	Shelter Demand In People	Surplus/Deficit In People	Shelter Capacity (ft2)	Surplus/Deficit (ft2)	Result
Storm Category 4/5	0	11,474	-11,474	0	-229,480	

**Special Needs Storm Shelters**

Name	Bldg #	Address	City	Zip			SpNS Capacity (spaces @ 60sf) (meets ARC 4496)	SpNs Capacity (sf) (meets ARC 4496)	SpNS Capacity (spaces @ 60sf) (does not meet ARC 4496)	local planned usage	Funding Source: Local (L), State (S), Federal (F), and Program Name	Comments
First Christian Church		20212 Peachland Blvd	Port Charlotte	33954	R	P	0	0				exiting storm only 15.9' SLOSH
							0	0				

Year 2012	SpNs Shelter Capacity In Spaces (meets ARC 4496)	SpNs Shelter Demand In Spaces	Surplus/Deficit In Spaces	SpNs Shelter Capacity (ft2)	Surplus/Deficit (ft2)	Result
Storm Category 4/5	0	1,352	-1,352	0	-81,120	

**2012 Statewide Emergency Shelter Plan  
Exiting Storm**

**CHARLOTTE**

Name	Bldg. #	Address	City	Zip	Retrofitted (R) or New Construction (N)	General (G), PSN (P), Pet-Friendly (A)	Total Risk Capacity In People (Meets ARC 4496)	Total Risk Capacity (ft <sup>2</sup> ) (Meets ARC 4496)	Risk Capacity In People (Does not Meet ARC 4496 or Not Yet Surveyed)	Local Planned usage (capacity reported)	Funding Source: Local (L), State (S), Federal (F), and Program Name	Comments
Liberty ES	café & hallways	370 Atwater Street	Port Charlotte	33952	R	G	351	5,259	149	500	L	exiting storm only (open span?) 1
Port Charlotte MS	café & hallways	23000 Midway Blvd NE	Port Charlotte	39952	R	G	916	13,739	84	1,000	L	exiting storm only 15.7' SLOSH
Kingsway ES	1st floor	23300 Quasar Blvd	Port Charlotte	33980	R	G	1,860	27,904	140	2,000	S-1467-2004	8.43' SLOSH
							0	0				
<b>TOTALS FOR CHARLOTTE COUNTY</b>							<b>3,127</b>	<b>46,902</b>	<b>373</b>	<b>3,500</b>		<b>0</b>
Year 2012	Shelter Capacity In People	Shelter Demand In People	Surplus/Deficit In People	Shelter Capacity (ft2)			Surplus/Deficit (ft2)	Result				
Storm Category 4/5	3,127	11,474	-8,347	46,902			-182,578					
Special Needs Storm Shelters												
Name	Bldg #	Address	City	Zip			SpNS Capacity (spaces @ 60sf) (meets ARC 4496)	SpNs Capacity (sf) (meets ARC 4496)	SpNS Capacity (spaces @ 60sf) (does not meet ARC 4496)	local planned usage	Funding Source: Local (L), State (S), Federal (F), and Program Name	Comments
First Christian Church		20212 Peachland Blvd	Port Charlotte	33954	R	P	0	0				
							0	0				
Year 2012	SpNs Shelter Capacity In Spaces (meets ARC 4496)	SpNs Shelter Demand In Spaces	Surplus/Deficit In Spaces	SpNs Shelter Capacity (ft2)			Surplus/Deficit (ft2)	Result				
Storm Category 4/5	0	1,352	-1,352	0			-81,120					

**2012 Statewide Emergency Shelter Plan**

**CITRUS**

Name	Bldg. #	Address	City	Zip	Retrofitted (R) or New Construction (N)	General (G), PSN (P), Pet-Friendly (A)	Total Risk Capacity In People (Meets ARC 4496)	Total Risk Capacity (ft <sup>2</sup> ) (Meets ARC 4496)	Risk Capacity In People (Does not Meet ARC 4496 or Not Yet Surveyed)	Local Planned usage (capacity reported)	Funding Source: Local (L), State (S), Federal (F), and Program Name	Comments
Central Florida Community College		3800 S. Lecanto Hwy.	Lecanto	34461		G	0	0				
Central Ridge ES	1&Café	185 W. Citrus Springs blvd	Citrus Springs	34443		G	0	0	1,146	1,146		
Citrus High School	16	600 West Highland Blvd	Inverness	34452	R	G	300	6,874		300	HMGP	updated FISH Data
Citrus High School	17	600 West Highland Blvd	Inverness	34452	R	G	288	5,319		288	HMGP	updated FISH Data
Citrus High School	café/21	600 West Highland Blvd	Inverness	34452	N	G	0	0			L	
Citrus Springs Elementary School	1 and 2	3570 West Century Blvd	Citrus Springs	34443		G	0	0	2,042	2,042		34,640 sqft per FISH
Citrus Springs MS	1	150 W Citrus Springs Blvd	Citrus Springs	34443	R	G	60	1,145		1,312	HMGP	updated FISH Data
Citrus Springs MS	2	150 W Citrus Springs Blvd	Citrus Springs	34443	R	G	344	6,542			HMGP	
Citrus Springs MS	3	150 W Citrus Springs Blvd	Citrus Springs	34443	R	G	312	5,932			HMGP	updated FISH Data
Citrus Springs MS	4	150 W Citrus Springs Blvd	Citrus Springs	34443	R	G	312	5,932			HMGP	updated FISH Data
Citrus Springs MS	8	150 W Citrus Springs Blvd	Citrus Springs	34443	R	G	313	5,952			HMGP	updated FISH Data
Crest School	1 and 2	2600 S. Panther Pride Drive	Lecanto	34461		G	0	0	1,222	1,271		18,323 sqft per FISH
First Assembly Church		4201 South Pleasant Grove Road	Inverness	N/A		G	0	0	0			
First Baptist Church		8545 E Magnolia	Floral City	N/A		G	0	0	0			
First Baptist Church of Inverness		123 S Seminole Avenue	Inverness	N/A		G	0	0	0			
First Christian Church		1005 Hillside Court	Inverness	N/A		G	0	0	0			
First Lutheran Church		1900 W Highway 44	Inverness	N/A		G	0	0	0			
First Presbyterian Church		206 Washington Avenue	Inverness	N/A			0	0	0			9.1' SLOSH
Floral City Community Center		8370 E. Orange Avenue	Floral City	N/A		G	0	0	0			
Floral City Elementary School		8457 E Marvin Street	Floral City	N/A		G	0	0	543			
Forest Ridge Elementary School	1	2927 North Forest Ridge	Hernando	34442	R	G	1,718	42,941		1,468	S-1523-2002	updated FISH Data
Hernando Elementary School		2975 E. Trailblazer Lane	Hernando	34442		G	0	0	600	1,470		
Highlands Emergency Center		4325 S Little Al Point	Inverness	N/A		G	0	0	0			
Hope Evangelical Lutheran Church		9425 N Citrus Springs Blvd	Citrus Springs	N/A		G	0	0	0			
Inverness Middle School		1950 North US Highway 41	Inverness	34450		G	0	0	2,157	988		
Inverness Primary School		206 South Lime Avenue	Inverness	34452		G	0	0	1,299	1,280		
Lecanto High School		3810 W Education Path	Lecanto	34461		G	0	0	3,400	3,710		
Lecanto Middle School		3800 W Education Path	Lecanto	N/A		G	0	0	0			
Lecanto Primary School		3790 W Education Path	Lecanto	34452		G,A	0	0	1,869	1,280		
Main Street Baptist Church		960 S Highway 41	Inverness	N/A		G	0	0	0			
Our Lady of Fatima		550 S Highway 41	Inverness	N/A		G	0	0	0			
Pleasant Grove Elementary		630 Pleasant Grove Road	Inverness	34452		G	0	0	600	525		
Riverside Christian Church		7771 N Carl G. Rose Hwy	Hernando	N/A		G	0	0	0			
Rock Crusher Elementary		814 S Rock Crusher Road	Homosassa	34448		G	0	0	1,500	457		in cat 3/4 zone
St. Elizabeth Anne Seton Hall		1180 Country Club B	Dunnellon	N/A		G	0	0	0			
St. Margaret Episcopal Church		114 N Osceola Avenue	Inverness	N/A		G	0	0	0			
V.F.W. Leroy Rokks		1930 S Highway 200	Hernando	N/A		G	0	0	0			
Withlacoochee Vocational Technical School		1201 W Main Hwy 44 West	Inverness	34450		G	0	0	2,075	516		
<b>TOTALS FOR CITRUS COUNTY</b>							<b>3,647</b>	<b>80,637</b>	<b>18,453</b>	<b>18,053</b>		<b>0</b>
<b>Year 2012</b>	<b>Shelter Capacity In People</b>	<b>Shelter Demand In People</b>	<b>Surplus/ Deficit In People</b>	<b>Shelter Capacity (ft<sup>2</sup>)</b>			<b>Surplus/ Deficit (ft<sup>2</sup>)</b>	<b>Result</b>				
Storm Category 4/5	3,647	12,467	-8,820	80,637			-168,703					
<b>Special Needs Storm Shelters</b>												

**2012 Statewide Emergency Shelter Plan**

**CITRUS**

Name	Bldg #	Address	City	Zip			SpNS Capacity (spaces @ 60sf) (meets ARC 4496)	SpNs Capacity (sf) (meets ARC 4496)	SpNS Capacity (spaces @ 60sf) (does not meet ARC 4496)	local planned usage	Funding Source: Local (L), State (S), Federal (F), and Program Name	Comments
Citrus High School	café/21	600 West Highland Blvd	Inverness	34452	N	P	128	7,736	0	157	L	updated FISH Data
Renaissance Center	1	3630 W. Educational Path	Lecanto	34461	N	P	0	0		91		
Lecanto MS		3800 W Education Path	Lecanto	34461	N	P	0	0	100	100		
Year 2012	SpNs Shelter Capacity In Spaces (meets ARC 4496)	SpNs Shelter Demand In Spaces	Surplus/ Deficit In Spaces	SpNs Shelter Capacity (ft2)			Surplus/ Deficit (ft2)	Result				
Storm Category 4/5	128	56	72	7,680			4,320					

**2012 Statewide Emergency Shelter Plan**

**CLAY**

Name	Bldg. #	Address	City	Zip	Retro fitted (R) or New Construction (N)	General (G), PSN (P), Pet-Friendly (A)	Total Risk Capacity In People (Meets ARC 4496)	Total Risk Capacity (ft <sup>2</sup> ) (Meets ARC 4496)	Risk Capacity In People (Does not Meet ARC 4496 or Not Yet Surveyed)	Local Planned usage (reported capacity)	Funding Source: Local (L), State (S), Federal (F), and Program Name	Comments
Argyle Elementary	Cafeteria, 2	2625 Spencer Plantation Blvd	OP	32073	N	G	225	4,373		225	L	ARC 4496
Clay High School	Cafeteria, 8	2025 SR 16 West	Green Cove Springs	32043		G,A	0	0	657	932		
Clay Hill Elementary School	5	6345 CR 218	Jacksonville	32234	R	G	263	5,079		263	F-HMGP	ARC 4496
Coppergate Elementary	Cafeteria	2250 CR 209 North	Middleburg	32068	N	G	311	6,220		311		ARC 4496
Fleming Island High		2233 Village Square Parkway	Orange Park	32003		G	0	0				EHPA EXEMPT
Green Cove Springs Junior HS	Cafeteria, 8	1220 Bonaventure Avenue	Gr Cove Springs	32043	R	G	404	6,060		443	1588-2006	ASCE7-93
Keystone Heights HS	Band, 7	900 SW Orchid Avenue	Keystone Heights	32656	R	G	179	2,678		184	1588-2006	ARC 4496
Keystone Heights HS	Cafeteria,5	900 SW Orchid Avenue	Keystone Heights	32656		G	0	0	584	584		
Keystone Heights HS	Gym, 9	900 SW Orchid Avenue	Keystone Heights	32656	R	G,A	859	16,960		859	1588-2006	ARC 4496
Lake Asbury Elementary School	6	2901 Sandridge Road	Gr Cove Springs	32043	R	G	265	5,784		265	F-HMGP	ARC 4496
Lake Asbury Elementary School	7	2901 Sandridge Road	Gr Cove Springs	32043	R	G	265	5,440		265	F-HMGP	ARC 4496
Lake Asbury Elementary School	5	2902 Sandridge Road	Gr Cove Springs	32044	R	G	0	0	275		S-1496-2009	shuttering projectd for 2010
Lake Asbury Junior HS	1	2851 Sandridge Rd	Gr Cove Springs	30243	N	G	298	5,576		298	L	ARC 4496
Lakeside Elementary School	6	2752 Moody Road	Orange Park	32073	R	G	0	0	258		F-HMGP	
Lakeside Elementary School	7	2752 Moody Road	Orange Park	32073	R	G	0	0	269		F-HMGP	
McRae Elementary School	Cafeteria , 2	6770 CR 315	Keystone Heights	32656		G	0	0	252	252		
Montclair Elementary School	4	2398 Moody Road	Orange Park	32073	R	G	265	5,480		265	S-EMPA	01CP-10-04-2003-103
Montclair Elementary School	5	2398 Moody Road	Orange Park	32073	R	G	265	5,738		265		
Oakleaf High School	Cafetorium-Bldg	4035 Plantation Oaks Blvd	Orange Park	32065	N	G	710	17,751		568	L	Projected Online August 2010
Oakleaf School	Bldg 1 (café and multipurpose)	4085 Plantation Oaks Blvd	Orange Park	32073	N	G	272	5,448		272		ARC4496
Oakleaf Village ES	Cafetorium	410 Oakleaf Village Park	Orange Park	32065	N	G	272	5,448		272	L	EHPA
Orange Park High School	Cafeteria, 10	2300 Kingsley Avenue	Orange Park	32073		G,A	0	0	746	746	HMGP	Shuttered-needs wall reinforcement
Plantation Oakes ES	Cafetorium	4150 Plantation Oaks Blvd	Orange Park	32065	N	G	272	5,448		272	L	Projected Online August 09
Rideout Elementary School	1	3065 Apalachicola Blvd	Middleburg	32068	N	G	395	7,900		395		only north wing is EHPA
Shadowlawn ES	Cafetorium	2945 CR 218	Green Cove Springs	32043	N	G	272	5,448		272	L	EHPA
Tynes ES	Cafeteria,2	1550 Tynes Boulevard	Middleburg	32068	R	G	244	4,804		244	1588-2006	roof questions?
W.E. Cherry Elem School - Wilkinson ES	Bldg 1/Cafetorium	420 Edson Avenue	Orange Park	32073		G	0	0	380			
	5	4965 CR 218 West	Middleburg	32068	R	G	0	0	258		1588-2006	ANSI A58.1

**TOTALS FOR CLAY COUNTY**      **6,036**      **121,635**      **3,679**      **8,452**      **0**

Year 2012	Shelter Capacity In People	Shelter Demand In People	Surplus/ Deficit In People	Shelter Capacity (ft2)	Surplus/ Deficit (ft2)	Result
Storm Category 4/5	6,036	9,039	-3,003	121,635	-59,145	

**Special Needs Storm Shelters**

Name	Bldg #	Address	City	Zip			SpNS Capacity (spaces @ 60sf) (meets ARC 4496)	SpNs Capacity (sf) (meets ARC 4496)	SpNS Capacity (spaces @ 60sf) (does not meet ARC 4496)	Local planned usage	Funding Source: Local (L), State (S), Federal (F), and Program Name	Comments
St. Johns River Community College	Thrasher/ 2	285 College Drive	Orange Park	32065	R	P	52	3,130		52		
St. Johns River Community College	D	285 College Drive	Orange Park	32065	R	P	51	3,100		51		
St. Johns River Community College	V	285 College Drive	Orange Park	32065	R	P	49	2,940		49		
							0	0				



2012 Statewide Emergency Shelter Plan

CLAY

CLAY											
							0	0			
							0				
Year 2012	SpNs Shelter Capacity In Spaces (meets ARC 4496)	SpNs Shelter Demand In Spaces	Surplus/ Deficit In Spaces	SpNs Shelter Capacity (ft2)			Surplus/ Deficit (ft2)	Result			
Storm Category 4/5	152	444	-292	9,120			-17,520				

**2012 Statewide Emergency Shelter Plan**

COLLIER												
Name	Bldg. #	Address	City	Zip	Retrofitted (R) or New Construction (N)	General (G), PSN (P), Pet - Friendly (A)	Total Risk Capacity In People (Meets ARC 4496)	Total Risk Capacity (ft <sup>2</sup> ) (Meets ARC 4496)	Risk Capacity In People (Does not Meet ARC 4496 or Not Yet Surveyed)	Local Planned usage (reported capacity)	Funding Source: Local (L), State (S), Federal (F), and Program Name	Comments
Ave Maria University	Main	SR 858	Immokalee	34121	N	G	0	0		500		not public shelter att 19' SLOSH
Baron Collier High School	Main/Café/Gym	5600 Cougar Lane	Naples	34105	R	P	0	0			L & F-HMGP	exiting storm only, 12.3' SLOSH
Big Cypress Elementary	2	3250 Golden Gate Blvd	Naples	34116	R	G	0	0		750	S-1543	exiting storm only - ARC exception, 16.2' SLOSH
Calusa Park Elementary	Café & 4 clrms	4600 Santa Barbara Blvd	Naples	34104	N	G	0	0		500	L	exiting storm only, 11.7' SLOSH
Corkscrew Middle School	Gym/café	419 First Street	Immokalee	34142	R	G	0	0		1,000	L	17' SLOSH
Cypress Palm Middle School	2&4	4255 18th Ave, NE	Naples	34120	N		0	0			L	Available 2008-exiting storm?-Cat 5-
Golden Gate High School	4&6 (café/gym)	2925 Titan Way (Magnolia)	Naples	34116	N	G	0	0		2,500	L	exiting storm only-new school-ehpa,
Golden Gate Intermediate	Gym/Café/Admin	5055 20th Place SW	Naples	34116	N	G	0	0		1,500	L	exiting storm only - ARC exception, 12' SLOSH
Golden Gate Middle School	Café/Admin	2701 48th Terr Sw	Naples	34116	N	G	0	0		1,500	L	exiting storm only, 14.3' SLOSH
Golden Terrace ES South	Café/Gym	2965 44th Terrace SW	Naples	33999	R	G	0	0		400	S-1543	exiting storm only, 14' SLOSH
Gulf Coast High School	Gym	7878 Immokalee Blvd	Naples	34110	R	G	0	0		2,500	F-HMGP	exiting storm only, 13.7' SLOSH
Highlands Elementary School	Café/Lib	1101 Lake Trafford Road	Immokalee	34142	R	G	500	10,000				
Immokalee Friendship House	Main	602 West Main Street	Immokalee	34112	N	G	150	3,000		150	S-EMPA	
Immokalee High School		710 Immokalee Road	Immokalee	34142			1,500	30,000		1,500	L	need to confirm shutters and which bldgs.
Immokalee Middle School	Café 8/9	3500 Lake Trafford Road	Immokalee	34142	R	G	857	12,860		1,000	L	
Lake Trafford Elementary School	Café/Gym	3500 Lake Trafford Road	Immokalee	34142	R	G	500	10,000				
Laurel Oak Elementary	2	7800 Immokalee Road	Naples	33942			0	0		500	S-1523	exiting storm only - ARC exception, 12.2' SLOSH
Lely Elementary School	Café	8125 Lely Cultural Blvd	Naples	34113	R	G	0	0		300		exiting storm, 12.6' SLOSH
Lely High	Gym	1 Lely High School Blvd	Naples	34113	N	G	0	0		1,500	L/HMGP	exiting storm only, 15.6' SLOSH
Manatee Elementary	Gym	1880 Manatee RD	Naples	34114	N	G	0	0				16.2' SLOSH
Mike Davis Elementary School	Café/Admin	3215 Magnolia Pond Driv	Naples	34116	N		0	0				exiting storm? 2008-2009, 14.3' SLOSH
Naples High School	Gym/Café/Admin	1100 Golden Eagle Circle	Naples	34102	R	G	0	0		1,000		exiting storm only- ARC exception, 12' SLOSH
North Naples Middle School	Café/Gym	16165 Learning Lane	Naples	3410	N	G	0	0		1,000	L	new School- ehpa- exiting storm only?, 11.2' SLOSH
North Naples Regional Park	Admin	15000 Livingston Road	Naples	34109	N	G,A	0	0		500	L	Pet Friendly-exiting storm only, 9.7' SLOSH
Oak Ridge Middle School	Café 8/9	151 State Rd 951	Naples	33999	R	G	0	0		1,500	L	exiting storm only - ARC exception, 12.7' SLOSH
Palmetto Ridge High School	Café/Gym	1655 Victory Lane	Naples	34120	N	G/P	0	0			L	new School - primary PSN, 18' SLOSH
Parkside Elementary School	Main	5322 Texas Ave	Naples	34112	N		0	0			L	Will replace Lely Elementary 2008-exiting storm, 15.6' SLOSH
Pelican Marsh ES	Café	9480 airport Rd North	Naples	34109	R	G	0	0	334	500	L	exiting storm only-long span roof issues., 13.7' SLOSH
Pine Ridge Middle School	Main	213 S 9th Street	naplesw	34142	R	G	0	0				13.5' SLOSH
Pinecrest Elementary School		313 9th Street South	immokalee	34142			500	10,000				
Sable Palm ES	Admin/Gym	4095 18th Ave,NE	Naples	34116	N	G	0	0		500	L	exiting storm only, 20.5' SLOSH
Veterans Memorial ES	1,4	15960 Veterans Memorial	Naples	34110	N	G	0	0				9.2' SLOSH
Village Oaks Elementary School	Admin	1501 SR 29	Immokalee	34142	R	G	750	12,647		750	L & S-1118A	
Vineyards Elementary School	Café/Gym	6225 Arbor Boulevard	North Naples	34119	R	G	0	0		750	S-1523	exiting storm only- ARC exception, 12.5' SLOSH
							0	0				
<b>TOTALS FOR COLLIER COUNTY</b>							<b>4,757</b>	<b>88,507</b>	<b>334</b>	<b>22,600</b>		
Year 2012	Shelter Capacity In People	Shelter Demand In People	Surplus/ Deficit In People	Shelter Capacity (ft2)			Surplus/ Deficit (ft2)				Result	
Storm Category 4/5	4,757	25,568	-20,811	88,507			-422,853					

**2012 Statewide Emergency Shelter Plan**

Special Needs Storm Shelters												
Name	Bldg #	Address	City	Zip			SpNS Capacity (spaces @ 60sf) (meets ARC 4496)	SpNs Capacity (sf) (meets ARC 4496)	Comments	Local Planned usage (reported capacity)	Funding Source: Local (L), State (S), Federal (F), and Program Name	Comments
Golden Gate High School	4	2925 Titan Way (Magnolia)	Naples	34116	N	P	0	0			L	existing storm only-new school-ehpa, 11.3' SLOSH
Golden Gate High School	6	2925 Titan Way (Magnolia)	Naples	34116	N	P	0	0			L	existing storm only-new school-ehpa, 11.3' SLOSH
Golden Gate High School	7	2925 Titan Way (Magnolia)	Naples	34116	N	P	0	0			L	existing storm only-new school-ehpa, 11.3' SLOSH
Golden Gate High School	8	2925 Titan Way (Magnolia)	Naples	34116	N	P	0	0			L	existing storm only-new school-ehpa, 11.3' SLOSH
Palmetto Ridge HS (1st Priority)	6	1655 Victory Lane	Naples	34120	N	P	0	0				2story, 18' SLOSH
Palmetto Ridge HS (1st Priority)	7	1655 Victory Lane	Naples	34120	N	P	0	0				1stirt, 18' SLOSH
Palmetto Ridge HS (1st Priority)	8	1655 Victory Lane	Naples	34120	N	P	0	0				18' SLOSH
Year 2012	SpNs Shelter Capacity In Spaces (meets ARC 4496)	SpNs Shelter Demand In Spaces	Surplus/ Deficit In Spaces	SpNs Shelter Capacity (ft2)			Surplus/ Deficit (ft2)	Result				
Storm Category 4/5	0	1,812	-1,812	0			-108,720					

**2012 Statewide Emergency Shelter Plan  
Exiting Storms**

**COLLIER**

Name	Bldg. #	Address	City	Zip	Retrofitted (R) or New Construction (N)	General (G), PSN (P), Pet-Friendly (A)	Total Risk Capacity In People (Meets ARC 4496)	Total Risk Capacity (ft <sup>2</sup> ) (Meets ARC 4496)	Risk Capacity In People (Does not Meet ARC 4496 or Not Yet Surveyed)	Local Planned usage (reported capacity)	Funding Source: Local (L), State (S), Federal (F), and Program Name	Comments	
Ave Maria University	Main	SR 858	Immokalee	34121	N	G	0	0		500		not public shelter att 19' SLOSH	
Baron Collier High School	Main/Café/Gym	5600 Cougar Lane	Naples	34105	R	P	2,344	46,895			L & F-HMGP	exiting storm only, 12.3' SLOSH	
Big Cypress Elementary	2	3250 Golden Gate Blvd	Naples	34116	R	G	239	3,590		750	S-1543	exiting storm only - ARC exception, 16.2' SLOSH	
Calusa Park Elementary	Café& 4 clrms	4600 Santa Barbara Blvd	Naples	34104	N	G	975	24,384		500	L	exiting storm only, 11.7' SLOSH	
Corkscrew Middle School	Gym/café	419 First Street	Immokalee	34142	R	G	392	5,876		1,000	L	17' SLOSH	
Cypress Palm Middle School	2&4	4255 18th Ave, NE	Naples	34120	N		750	20,000			L	Available 2008-exiting storm?-Cat 5-	
Golden Gate High School	4&6 (café/gym)	2925 Titan Way (Magnolia)	Naples	34116	N	G	2,027	30,407		2,500	L	exiting storm only-new school-ehpa,	
Golden Gate Intermediate	Gym/Café/Adm	5055 20th Place SW	Naples	34116	N	G	1,500	30,000		1,500	L	exiting storm only - ARC exception, 12' SLOSH	
Golden Gate Middle School	Café/Admin	2701 48th Terr Sw	Naples	34116	N	G	1,500	30,826		1,500	L	exiting storm only, 14.3' SLOSH	
Golden Terrace ES South	Café/Gym	2965 44th Terrace SW	Naples	33999	R	G	280	4,199		400	S-1543	exiting storm only, 14' SLOSH	
Gulf Coast High School	Gym	7878 Immokalee Blvd	Naples	34110	R	G	1,442	21,624		2,500	F-HMGP	exiting storm only, 13.7' SLOSH	
Highlands Elementary School	Café/Lib	1101 Lake Trafford Road	Immokalee	34142	R	G	500	10,000					
Immokalee Friendship House	Main	602 West Main Street	Immokalee	34112	N	G	150	3,000		150	S-EMPA		
Immokalee High School		710 Immokalee Road	Immokalee	34142			1,500	30,000		1,500	L	need to confirm shutters and which bldgs.	
Immokalee Middle School	Café 8/9	3500 Lake Trafford Road	Immokalee	34142	R	G	857	12,860		1,000	L		
Lake Trafford Elementary School	Café/Gym	3500 Lake Trafford Road	Immokalee	34142	R	G	500	10,000					
Laurel Oak Elementary	2	7800 Immokalee Road	Naples	33942			264	2,677		500	S-1523	exiting storm only - ARC exception, 12.2' SLOSH	
Lely Elementary School	Café	8125 Lely Cultural Blvd	Naples	34113	R	G	300	6,000		300		exiting storm, 12.6' SLOSH	
Lely High	Gym	1 Lely High School Blvd	Naples	34113	N	G	1,500	30,000		1,500	L/HMGP	exiting storm only,15.6' SLOSH	
Manatee Elementary	Gym	1880 Manatee RD	Naples	34114	N	G	0	0				16.2' SLOSH	
Mike Davis Elementary School	Café/Admin	3215 Magnolia Pond Driv	Naples	34116	N		500	20,000				exiting storm? 2008-2009, 14.3' SLOSH	
Naples High School	Gym/Café/Admin	1100 Golden Eagle Circle	Naples	34102	R	G	0	0		1,000		exiting storm only- ARC exception, 12' SLOSH	
North Naples Middle School	Café/Gym	16165 Learning Lane	Naples	3410	N	G	1,000	18,853		1,000	L	new School- ehpa- exiting storm only?, 11.2' SLOSH	
North Naples Regional Park	Admin	15000 Livingston Road	Naples	34109	N	G/A	500	10,000		500	L	Pet Friendly-exiting storm only, 9.7' SLOSH	
Oak Ridge Middle School	Café 8/9	151 State Rd 951	Naples	33999	R	G	741	11,121		1,500	L	exiting storm only - ARC exception, 12.7' SLOSH	
Palmetto Ridge High School	Café/Gym	1655 Victory Lane	Naples	34120	N	G/P	1,500	50,000			L	new School - primary PSN, 18' SLOSH	
Parkside Elementary School	Main	5322 Texas Ave	Naples	34112	N		500	10,000			L	Will replace Lely Elementary 2008-exiting storm, 15.6' SLOSH	
Pelican Marsh ES	Café	9480 airport Rd North	Naples	34109	R	G	0	0	334	500	L	exiting storm only-long span roof issues., 13.7' SLOSH	
Pine Ridge Middle School	Main	213 S 9th Street	naplesw	34142	R	G	0	0				13.5' SLOSH	
Pinecrest Elementary School		313 9th Street South	immokalee	34142			500	10,000					
Sable Palm ES	Admin/Gym	4095 18th Ave,NE	Naples	34116	N	G	500	10,000		500	L	exiting storm only, 20.5' SLOSH	
Veterans Memorial ES	1,4	15960 Veterans Memoria	Naples	34110	N	G	500	10,000				9.2' SLOSH	
Village Oaks Elementary School	Admin	1501 SR 29	Immokalee	34142	R	G	750	12,647		750	L & S-1118A		
Vineyards Elementary School	Café/Gym	6225 Arbor Boulevard	North Naples	34119	R	G	902	22,554		750	S-1523	exiting storm only- ARC exception, 12.5' SLOSH	
							0	0					
<b>TOTALS FOR COLLIER COUNTY</b>							<b>24,913</b>	<b>507,513</b>	<b>334</b>	<b>22,600</b>			
<b>Year 2012</b>	<b>Shelter Capacity In People</b>	<b>Shelter Demand In People</b>	<b>Surplus/ Deficit In People</b>	<b>Shelter Capacity (ft2)</b>			<b>Surplus/ Deficit (ft2)</b>				<b>Result</b>		
Storm Category 4/5	24,913	25,568	-655	507,513			-3,847						

Special Needs Storm Shelters

**2012 Statewide Emergency Shelter Plan  
Exiting Storms**

Name	Bldg #	Address	City	Zip			SpNs Capacity (spaces @ 60sf) (meets ARC 4496)	SpNs Capacity (sf) (meets ARC 4496)	Comments	Local Planned usage (reported capacity)	Funding Source: Local (L), State (S), Federal (F), and Program Name	Comments
Golden Gate High School	4	2925 Titan Way (Magnolia)	Naples	34116	N	P	0	0			L	exiting storm only-new school-ehpa, 11.3' SLOSH
Golden Gate High School	6	2925 Titan Way (Magnolia)	Naples	34116	N	P	0	0			L	exiting storm only-new school-ehpa, 11.3' SLOSH
Golden Gate High School	7	2925 Titan Way (Magnolia)	Naples	34116	N	P	0	0			L	exiting storm only-new school-ehpa, 11.3' SLOSH
Golden Gate High School	8	2925 Titan Way (Magnolia)	Naples	34116	N	P	0	0			L	exiting storm only-new school-ehpa, 11.3' SLOSH
Palmetto Ridge HS (1st Priority)	6	1655 Victory Lane	Naples	34120	N	P	115	6,930				2story, 18' SLOSH
Palmetto Ridge HS (1st Priority)	7	1655 Victory Lane	Naples	34120	N	P	95	5,701				1stirt, 18' SLOSH
Palmetto Ridge HS (1st Priority)	8	1655 Victory Lane	Naples	34120	N	P	273	16,416				18' SLOSH
<b>Year 2012</b>	<b>SpNs Shelter Capacity In Spaces (meets ARC 4496)</b>	<b>SpNs Shelter Demand In Spaces</b>	<b>Surplus/ Deficit In Spaces</b>	<b>SpNs Shelter Capacity (ft2)</b>			<b>Surplus/ Deficit (ft2)</b>	<b>Result</b>				
Storm Category 4/5	483	1,812	-1,329	28,980			-79,740					

2012 Statewide Emergency Shelter Plan

**COLUMBIA**

Name	Bldg. #	Address	City	Zip	Retrofitted (R) or New Construction (N)	General (G), PSN (P), Pet-Friendly (A)	Total Risk Capacity In People (Meets ARC 4496)	Total Risk Capacity (ft <sup>2</sup> ) (Meets ARC 4496)	Risk Capacity In People (Does not Meet ARC 4496 or Not Yet Surveyed)	Local Planned usage (reported capacity)	Funding Source: Local (L), State (S), Federal (F), and Program Name	Comments
Columbia City ES	B3	7438 SW SR 47	Lake City	32024	N	G	232	4,642				online 2006- EHPA- Rm 17-20
Columbia High School	B2/ Auditorium	469 SE Fighting Tiger Drive	Lake City	32025	N	G	514	10,270				online 2006-EHPA
Columbia High School	B7/ Cafeteria	470 SE Fighting Tiger Drive	Lake City	32025	N	G	331	6,628				online 2007-EHPA
Fort White ES	1	18119 SW SR 47	Lake City	32038	N	G	403	10,073		365	L,S,F	
Fort White High School	11-1st floor	17828 SW SR 47	Lake City	32038	N	G	135	2,702			L	PER fdem REPORT
Fort White High School	12-1st floor	17828 SW SR 47	Lake City	32038	N	G	136	2,724			L	PER fdem REPORT
Fort White High School	17	17828 SW SR 47	Lake City	32038	N	G	167	3,344				updated FISH data
Lake City MS	16	843 SW Arlington Blvd	Lake City	32055	N	G	201	4,018				updated FISH data
Pine Mount ES	2	325 SW Gabriel PL	Lake City	32024	N	G	221	4,415				per ehpa list
Pine Mount ES	3	326 SW Gabriel PL	Lake City	32024	N	G	211	4,230				updated FISH data
Pine Mount ES	4	327 SW Gabriel PL	Lake City	32024	N	G	295	5,902				updated FISH data
Pine Mount ES	6	328 SW Gabriel PL	Lake City	32024	N	G	161	3,221				updated FISH data
Westside Elementary	2	1956 SW County Rd 252B	Lake City	32024	N	G	237	4,731				updated FISH data
Westside Elementary	3	1956 SW County Rd 252B	Lake City	32024	N	G	243	4,852				updated FISH data
Westside Elementary	4	1956 SW County Rd 252B	Lake City	32024	N	G	176	3,526				updated FISH data
Westside Elementary	5	1956 SW County Rd 252B	Lake City	32024	N	G	183	3,664				updated FISH data
Westside Elementary	6	1956 SW County Rd 252B	Lake City	32024	N	G	243	4,858				updated FISH data
Westside Elementary	9	1956 SW County Rd 252B	Lake City	32024	N	G	248	4,954				updated FISH data
<b>TOTALS FOR COLUMBIA COUNTY</b>							4,337	88,754	0	365		0
<b>Year 2012</b>	<b>Shelter Capacity In People</b>	<b>Shelter Demand In People</b>	<b>Surplus/ Deficit In People</b>	<b>Shelter Capacity (ft2)</b>			<b>Surplus/ Deficit (ft2)</b>	<b>Result</b>				
Storm Category 4/5	4,337	3,844	493	88,754			11,874					
<b>Special Needs Storm Shelters</b>												
<b>Name</b>	<b>Bldg #</b>	<b>Address</b>	<b>City</b>	<b>Zip</b>			<b>SpNS Capacity (spaces @ 60sf) (meets ARC 4496)</b>	<b>SpNs Capacity (sf) (meets ARC 4496)</b>	<b>SpNS Capacity (spaces @ 60sf) (does not meet ARC 4496)</b>	<b>local planned usage</b>	<b>Funding Source: Local (L), State (S), Federal (F), and Program Name</b>	<b>Comments</b>
VA Domilery							0	0	16	16		
<b>Year 2012</b>	<b>SpNs Shelter Spaces In People (meets ARC 4496)</b>	<b>SpNs Shelter Demand In Spaces</b>	<b>Surplus/ Deficit In Spaces</b>	<b>SpNs Shelter Capacity (ft2)</b>			<b>Surplus/ Deficit (ft2)</b>	<b>Result</b>				
Storm Category 4/5	0	426	-426	0			-25,560					

**2012 Statewide Emergency Shelter Plan**

**DESOTO**

Name	Bldg. #	Address	City	Zip	Retrofitted (R) or New Construction (N)	General (G), PSN (P), Pet-Friendly (A)	Total Risk Capacity In People (Meets ARC 4496)	Total Risk Capacity (ft <sup>2</sup> ) (Meets ARC 4496)	Risk Capacity In People (Does not Meet ARC 4496 or Not Yet Surveyed)	Local Planned usage (reported capacity)	Funding Source: Local (L), State (S), Federal (F), and	Comments
Childs Christian Life Center Gym	Gym	1006 North Brevard Avenue	Arcadia	34233		G	0	0	0			Doesn't meet ARC 4496
County Administration Building	1	201 East Oak Street	Arcadia	34266	R	G	192	2,886	0	289	L, F	
County Library		125 North Hillsborough Avenue	Arcadia	34266	R	G	144	2,160	0	184	L, F	
DeSoto Ms	5-Gym	420 E. Gibson Street	Arcadia	34266	R	G	583	10,776		583	1508-200	updated FISH Data
DeSoto MS	Bldg-6	420 E. Gibson Street	Arcadia	34266	R	G	481	9,985		481	1508-200	completed 12/05
DeSoto Ms	Bldg-7	420 E. Gibson Street	Arcadia	34266	R	G	481	9,985		481	HMGP	completed 2/06
DeSoto Ms	Bldg-8	420 E. Gibson Street	Arcadia	34266	R	G	481	9,981		481	Hmgrp	completed 2/06
First Baptist Church		1006 North Brevard Avenue	Arcadia	34266		P	0	0	264			Doesn't meet ARC 4496
First Presbyterian Church		209 West Hickory Street	Arcadia	34266		G	0	0	235			
Memorial Elementary School	2-B	851 East Hickory Street	Arcadia	34266		G	0	0	495			
Memorial Elementary School	3-C	851 East Hickory Street	Arcadia	34266		G	0	0	495			
Memorial Elementary School	5-E	851 East Hickory Street	Arcadia	34266		G	0	0	396			
Memorial Elementary School	7-G	851 East Hickory Street	Arcadia	34266		G	0	0	213			
Memorial Elementary School	Bldg H	851 E. Hickory Street	Arcadia	34266	R	G	180	3,600		180	HB7121	
South Florida Community College		2251 NE Turner	Arcadia	34266	N	P	0	0			EHPA	SpNS shelter-see below
Trinity United Methodist #1		304 West Oak Street	Arcadia	33821		G	0	0	175			
Trinity United Methodist #2		304 West Oak Street	Arcadia	33821		G	0	0	140			
Turner Agri-Civic Center		2250 Northeast Roan Street	Arcadia	34266	N	G	0	0	0		L,F	\$200k Agricultural grant-decommissioned
Turner Center Exhibit Hall		2260 NE Roan	Arcadia	34266	R	P	0	0	0		L,F/Hmgrp/ S-1	SpNS shelter-see below
West Elementary School	13-A	304 West Imogene Avenue	Arcadia	34266		G	0	0	233			
West Elementary School	14-B	304 West Imogene Avenue	Arcadia	34266		G	0	0	326			
West Elementary School	15-C	304 West Imogene Avenue	Arcadia	34266		G	0	0	326			
West Elementary School	16-D	304 West Imogene Avenue	Arcadia	34266		G	0	0	215			
West Elementary School	17-E	304 West Imogene Avenue	Arcadia	34266		G	0	0	244			
West Elementary School	18-F	304 West Imogene Avenue	Arcadia	34266		G	0	0	167			
<b>TOTALS FOR DESOTO COUNTY</b>							<b>2,542</b>	<b>49,373</b>	<b>4,511</b>	<b>2,782</b>		<b>0</b>
Year 2012	Shelter Capacity In People	Shelter Demand In People		Surplus/Deficit In People	Shelter Capacity (ft <sup>2</sup> )		Surplus/Deficit (ft <sup>2</sup> )	Result				
Storm Category 4/5	2,542	3,159		-617	49,373		-13,807					
<b>Special Needs Storm Shelters</b>												

**2012 Statewide Emergency Shelter Plan**

Name	Bldg #	Address	City	Zip			SpNS Capacity (spaces @ 60sf) (meets ARC 4496)	SpNS Capacity (sf) (meets ARC 4496)	Comments	Local Planned usage (reported capacity)	Funding Source: Local (L), State (S), Federal (F), and Program Name	Comments
South Florida Comm. College (Priority 1)		2251 NE Turner	Arcadia	34266	N	P	151	7,194	Note: EHPA	151		
Turner Center Exhibit Hall (Priority 2)		2260 NE Roan	Arcadia	34266	R	P	60	2,400		140		
Year 2012	SpNs Shelter Capacity In Spaces (meets ARC 4496)	SpNs Shelter Demand In Spaces	Surplus/ Deficit In Spaces	SpNs Shelter Capacity (ft2)			Surplus/ Deficit (ft2)	Result				
Storm Category 4/5	211	571	-360	12,660			-21,600					



**2012 Statewide Emergency Shelter Plan**

**DIXIE**

Name	Bldg. #	Address	City	Zip	Retrofitted (R) or New Construction (N)	General (G), PSN (P), Pet Friendly (A)	Total Risk Capacity In People (Meets ARC 4496)	Total Risk Capacity (ft <sup>2</sup> ) (Meets ARC 4496)	Risk Capacity In People (Does not Meet ARC 4496 or Not Yet Surveyed)	Local Planned usage (reported capacity)	Funding Source: Local (L), State (S), Federal (F), and Program Name	Comments
Anderson Elementary School		815 SE 351 Hwy	Cross City	32628		G	0	0				
Dixie County High School		16077 SE 19 Hwy	Cross City	32628		G	0	0				
Old Town Elementray	1	221 SE 136 Ave	Old Town	32680	R	G	0	0		106	S-1435A	205 persons, Exiting storm only
Old Town Elementray	2	221 SE 136 Ave	Old Town	32680	R	G	0	0		460	S-1435A	460 persons, Exiting storm only
Old Town Elementray	3	221 SE 136 Ave	Old Town	32680	R	G	0	0		321	S-1435A	321 persons, Exiting storm only
Old Town Elementray	4	221 SE 136 Ave	Old Town	32680	R	G	0	0		165	S-1435A	165 persons, Exiting storm only
Old Town Elementray	5	221 SE 136 Ave	Old Town	32680	R	G	0	0		175	S-1435A	74 persons, Exiting storm only
Old Town Elementray	7	221 SE 136 Ave	Old Town	32680	N	P	0	0			L	SPNS-see below,
Ruth Raines Middle School	1South & 1n	981 SE 351 HWY	Cross City	32628	R	G	489	9,788		489	S-1435A	WD 2002 Values
Ruth Raines Middle School	2	981 SE 351 HWY	Cross City	32628	R	G	61	1,272		61	S-1435A	Updated FISH Data
Ruth Raines Middle School	3	981 SE 351 HWY	Cross City	32628	R	G	206	5,148		160	S-1435A	
Ruth Raines Middle School		981 SE 351 HWY	Cross City	32628	R	G	0	0		0	S-1435A	
Ruth Raines Middle School	5	981 SE 351 HWY	Cross City	32628	R	G	70	1,406		70	S-1435A	WD 2002 Values

**TOTALS FOR DIXIE COUNTY**

**826      17,614      0      2,007**

Year 2012	Shelter Capacity In People	Shelter Demand In People	Surplus/ Deficit In People	Shelter Capacity (ft2)	Surplus/ Deficit (ft2)	Result
Storm Category 4/5	826	1,502	-676	17,614	-12,426	

**Special Needs Storm Shelters**

Name	Bldg #	Address	City	Zip			SpNS Capacity (spaces @ 60sf) (meets ARC 4496)	SpNs Capacity (sf) (meets ARC 4496)	Comments	Local Planned usage (reported capacity)	Funding Source: Local (L), State (S), Federal (F), and Program Name	Comments
Old Town ES	7/Café	221 SE 136 Ave	Old Town	32680	N	P	0	0		84		Note: EHPA Updated FISH Data, 84 persons exiting storm only

Year 2012	SpNs Shelter Spaces In People (meets ARC 4496)	SpNs Shelter Demand In Spaces	Surplus/ Deficit In Spaces	SpNs Shelter Capacity (ft2)	Surplus/ Deficit (ft2)	Result
Storm Category 4/5	0	148	-148	0	-8,880	

2012 Statewide Emergency Shelter Plan

DUVAL

Name	Bldg. #	Address	City	Zip	Retrofitted (R) or New Construction (N)	General (G), PSN (P), Pet Friendly (A)	Total Risk Capacity In People (Meets ARC 4496)	Total Risk Capacity (ft2) (Meets ARC 4496)	Risk Capacity In People (Does not Meet ARC 4496 or Not Yet Surveyed)	Local planned usage (capacity reported)	Comments
103 ST K-8 School	North side of school cafeteria, gymnasium, & PMH wing	5270 Connie Jean Road	Jacksonville	32210	N	G	817	16,340		817	Opens August 2009, may be used in late 2009 Season - Applied for HMGP 1679 (Tier III)/ & PDM \$ no response.
Andrew A. Robinson Elementary School	bldg 1, bldg 2	101 12th Street West	Jacksonville	32206	R	G	1,898	47,451		1,853	HMGP1306-106 HMGP1539.
AAA HIGH SCHOOL	TBA	9735 AC Skinner Parkwy	Jacksonville	32256	N	G	850	17,000		850	to open August 2010, effective 2011 Season - Applied for HMGP 1679 and PDM \$ no response.
Abess Park Elementary	main (1st flr)	12731 Abess Blvd	Jacksonville	32225	R	G	1,369	26,559		1,369	HMGP1300-108 HMGP 1545- effective 2008.
Abess Park Elementary	main (2nd flr)	12731 Abess Blvd	Jacksonville	32225	R	G	1,244	27,380		1,369	HMGP 1561-235.
Abess Park Elementary	additional to previous	12731 Abess Blvd	Jacksonville	32225	R	G	1,244	24,880		1,244	HMGP 1561- HMGP 1545 effective 2008.
Abess Park Elementary	additional to previous	12731 Abess Blvd	Jacksonville	32225	R	G					New totals for Abess Park EL.
Alfred I. Dupont Middle School		2710 Dupont Avenue	Jacksonville	32217							
Andrew Jackson High School		3816 Main Street North	Jacksonville	32206							
Arlington Middle School	1	8141 Lone Star Road	Jacksonville	32211	N	G	2,517	50,331			Updated fish data.
Arlington Middle School	2	8141 Lone Star Road	Jacksonville	32211	N	G	450	8,996			Updated fish data.
Arlington Middle School	3	8141 Lone Star Road	Jacksonville	32211	N	G	211	4,218			Updated fish data.
Axson ES	2	4763 Sutton Park Court	Jacksonville	32224	N	G	206	4,119			per EHPA Isit.
Bartram Springs ES	1 CLASSROOMS WING C, Teacher Planning Area	14799 Bartram Springs Parkway	Jacksonville	32258	N	G	436	8,720		436	Opens August 2009, may be used in late 2009 Season - Applied for HMGP 1679 (Tier III)/ & PDM \$ no response.
Axson ES	3	4763 Sutton Park Court	Jacksonville	32224	N	G	763	15,269			per EHPA Isit.
Axson ES	4	4763 Sutton Park Court	Jacksonville	32224	N	G	316	6,312		300	per EHPA Isit.
Baldwin M/HS	cafeteria/gym	291 Mills Street	Baldwin	32224	R	G					HB7121-not done.
Biltmore Elementary School		2101 West Palm Avenue	Jacksonville	32254							
Brookview Elementary School		10450 Theresa Drive	Jacksonville	32246							
Carter G. Woodson Elementary School		2334 Butler Avenue	Jacksonville	32209							
Chaffee Trail ES	1	11400 Sam Caruso Way	Jacksonville	32221	N	G	800	16,000		800	OPENED AUG 2007
Chets Creek Elementary School	main (1st flr)	13200 Chets Creek Blvd	Jacksonville	32224	R	G	1,369	27,114		1,369	HMGP1300-107 HMGP 1539,
Chets Creek Elementary School	main (2nd flr)	13200 Chets Creek Blvd	Jacksonville	32244	R	G	1,369	27,380		1,369	roof issues -HMGP 1561-235 HMGP 1539,
Chets Creek Elementary School	additional to previous	13200 Chets Creek Blvd	Jacksonville	32244	R	G	1,244	24,880		1,244	HMGP 1561-online April 2008,
Chimney Lake Elementary School	A,B, D(1st floor)	9353 Staples Mill Road	Jacksonville	32244	R	G,A	2,367	59,184		1,298	HMGP1300-105 HB7121,
Chimney Lakes ES	additional to previous-2nd floor	9353 Staples Mill Dr.	Jacksonville	32244	R	G,A	1,298	25,960		2,596	HB7121-additional to previous-engineering study,
Crystal Springs ES	additional to previous-2nd floor	1200 Hammond Blvd.	Jacksonville	32221	R	G	1,361	27,220		2,722	HB7121-additional to previous/engineering study,
Crystal Springs Elementary School	D(1st flr)	1200 Hammond Boulevard	Jacksonville	32221	R	G	1,361	27,220		1,361	HMGP1300-111 (laydown) HB7121,
Crystal Springs Elementary School	additional to previous-	1200 Hammond Blvd.	Jacksonville	32221	R	G	588	11,760		588	HB7121-additional to previous- eng study in progress.
Don Brewer Elementary School	main (1st flr)	3385 Hartsfield	Jacksonville	32211	N	G	801	20,024		537	
Edward White Sr High School		1700 Old Middleburg Road	Jacksonville	32210		G					
Englewood Sr. High School		4412 Barnes Road	Jacksonville	32207		G					
Enterprise Learning Academy	main (1st flr)	8085 Old Middleburg Road	Jacksonville	32222	R	P					changed to pSn HB7121.
Eugene Butler Middle School		900 Acorn Street	Jacksonville	32209		G					
Fla State College Jacksonville (FSCJ) CECIL FIELD	Aviation Bldg. #2	13450 Lake Fretwell St.	Jacksonville	32221	N	G	708	14,160		708	Effective 2009 Hurricane Season - built with State DOE \$.
First Coast High School		590 Duval Station Road	Jacksonville	32218		G					
Ft. Caroline Middle School		3757 University Club Blvd	Jacksonville	32277		G					HMGP1300-109.
Garden City Elementary School		2814 Dunn Avenue	Jacksonville	32218		G					exiting storm only 1.97' SLOSH
Greenland Pines		5050 Greenland Road	Jacksonville	32258	R	G				1,680	
Highlands Middle School		10913 Pine Estate Road	Jacksonville	32218		G					exiting storm only 4' SLOSH
Hyde Park Elementary School		5300 Park Street	Jacksonville	32205		G					
J.E.B. Stuart Middle School		4815 Wesconnett Blvd	Jacksonville	32210		G					
Jacksonville Heights Elementary School		7750 Tempest Street South	Jacksonville	32244		G					
Jefferson Davis Middle School		7050 Melvin Road	Jacksonville	32210		G					
Joseph Stilwell Middle School		7840 Burma Road	Jacksonville	32221		G					



**2012 Statewide Emergency Shelter Plan**

DUVAL											
103 ST K-8 School	North side of school - Classrooms, band and vocal rooms	5270 Connie Jean Road	Jacksonville	32210	N	P	167	10,020		167	Opens August 2009, may be used in late 2009 Season - Applied for HMGP 1679 (Tier III)/ & PDM \$ no response.
Bartram Springs ES	Cafetorium	14799 Bartram Springs Parkway	Jacksonville	32258	N	p	110	6,660		436	Opens August 2009, may be used in late 2009 Season - Applied for HMGP 1679 (Tier III)/ & PDM \$ no response.
Enterprise Learning Academy (2nd Priority)	Main (1st flr)	8085 Old Middleburg Road	Jacksonville	32222	R	P	540	21,600		671	HB7121 SpNs generator project - updated figures 08-15-08 with DCPS for 60 S.F.
Landmark MS (Priority 4)	Main (1st flr)	101 Kernan Road	Jacksonville	32225	R	P,A	0	0	0	496	updated figures 08-15-08 with DCPS for 60 S.F.
Mandarin MS (priority 3)	1#63-70	5100 Hood Road	Jacksonville	32257	R	P	0	0	114	496	HB7121 eng. Study in progress.
AAA HIGH SCHOOL	TBA	9735 AC Skinner Parkwy	Jacksonville	32256	N	G/P	250	15,000		250	to open August 2010, effective 2011 Season - Applied for HMGP 1679 and PDM \$ no response
City of Jacksonville NW Community Center	1	5130 Soutel Drive	Jacksonville	32208	N	G/P	62	3,720		62	Construction to begin fall 2009 -to open Fall 2010 - Shelter effective 2011 Season - City CIP & CDBG & HB7121 funds.
Waterleaf ES	1 Wing (c) cafetorium teacher planning area	TBA - Kernan Blvd in East Arlington	Jacksonville	32225	N	P	219	13,140		219	DESIGN ON HOLD-economy doesn't support construction -tentatively scheduled for 2011 Season.
Oceanway MS (1st Priority)	2-café	143 Oceanway Avenue	Jacksonville	32218	R	P	172	6,884	0	200	Note; EHPA.
Twin Lakes Academy / ES (priority 5)	special needs only	8000 Point Meadows Drive	Jacksonville	32256	R	P	857	53,969	0	857	updated figures 08-15-08 with DCPS for 60 S.F.
<b>Year 2012</b>	<b>SpNs Shelter Capacity In Spaces (meets ARC 4496)</b>	<b>SpNs Shelter Demand In Spaces</b>	<b>Surplus/ Deficit In Spaces</b>	<b>SpNs Shelter Capacity (ft2)</b>			<b>Surplus/ Deficit (ft2)</b>	<b>Result</b>			
Storm Category 4/5	2,377	4,385	-2,008	142,620			-120,480				

2012 Statewide Emergency Shelter Plan

ESCAMBIA												
Name	Bldg. #	Address	City	Zip	Retrofitted (R) or New Construction (N)	General (G), PSN (P), Pet-Friendly (A)	Total Risk Capacity In People (Meets ARC 4496)	Total Risk Capacity (ft <sup>2</sup> ) (Meets ARC 4496)	Risk Capacity In People (Does not Meet ARC 4496 or Not Yet Surveyed)	Local Planned usage (reported capacity)	Funding Source: Local (L), State (S), Federal (F), and Program Name	Comments
Bailey MS	1	4110 Bauer Road	Pensacola	32506	R	G	0	0		0	S-1435A-2003	located in Cat 2-3 evac zone; updated F.I.S.H.
Bailey MS	3	4110 Bauer Road	Pensacola	32506	R	G	0	0		0	S-1435A-2003	located in Cat 2-3 evac zone; updated F.I.S.H.
Bailey MS	4	4110 Bauer Road	Pensacola	32506	R	G	0	0		0		long span question
Bailey MS	5	4110 Bauer Road	Pensacola	32506	R	G	0	0		0		long span question
Bailey MS	6	4110 Bauer Road	Pensacola	32506	R	G	0	0		0	S-1435A-2003	located in Cat 2-3 evac zone; updated F.I.S.H.
Bailey MS	7	4110 Bauer Road	Pensacola	32506	R	G	0	0		0	S-1435A-2003	located in Cat 2-3 evac zone; updated F.I.S.H.
Bailey MS	8	4110 Bauer Road	Pensacola	32506	R	G	0	0		0	S-1435A-2003	located in Cat 2-3 evac zone; updated F.I.S.H.
Bailey MS	9	4110 Bauer Road	Pensacola	32506	R	G	0	0		0		long span question
Bellview Assembly of God		2920 W. Michigan Avenue	Pensacola	32526		G	0	0				
Bellview Baptist Church		4750 Saufley Rd	Pensacola	32526		G	0	0				
Bellview Elementary School <sup>l</sup>	5	4425 Bellview Avenue	Pensacola	32506	R	G	309	5,420		309	S-1435A-2003	
Bellview Middle School <sup>l</sup>		6201 Mobile Highway	Pensacola	32506	R	G	0	0				
Beulah Elementary School <sup>l</sup>	2000 add	6201 Helms Road	Pensacola	32506		G	185	3,693		0	S-1435A-2003	Updated F.I.S.H. Data
Beulah Elementary School <sup>l</sup>	Main	6201 Helms Road	Pensacola	32506	R	G	0	0			F,S,L -Hmgrp	
Blue Angel ES	100 wing	1551 Dog Track Road	Pensacola	32506	R	G	274	6,851		98	L	per State study; Updated F.I.S.H. Data
Blue Angel ES	200 wing	1551 Dog Track Road	Pensacola	32506	R	G	200	5,005		120	L	per State study; Updated F.I.S.H. Data
Blue Angel ES	300 wing	1551 Dog Track Road	Pensacola	32506	R	G	354	6,222		354	L	per State study; Updated F.I.S.H. Data
Blue Angel ES	400 wing	1551 Dog Track Road	Pensacola	32506	R	G	419	7,701		419	L	per State study; Updated F.I.S.H. Data
Blue Angel ES	500 wing	1551 Dog Track Road	Pensacola	32506	R	G	463	7,842		463	L	per State study; Updated F.I.S.H. Data
Blue Angel ES	600 wing	1551 Dog Track Road	Pensacola	32506	R	G	406	8,653		406	L	per State study; Updated F.I.S.H. Data
Brentwood ES	5	4820 North Palaof	Pensacola	32505	R	G	427	8,532		0	1588-2006	shutters complete July 2007; Updated F.I.S.H. Data
Brownsville Middle School <sup>l</sup>		3700 West Avery Street	Pensacola	32503	R	G	0	0				
Carver Middle School <sup>l</sup>		700 E Hecker Road	Century	32525	R	G	0	0				
Century- Carver Middle School	7	440 East hecker Road	Century	32535	R	G	547	11,029		547		Updated F.I.S.H. Data (R & N Totals)
Charity Chapel		5820 Montgomery Ave	Pensacola	32526		G	0	0				
Circle Baptist		808 New Warrington Rd	Pensacola	32505		G	0	0				
Community Workshop Center		6200 West Nine Mile Rd	Pensacola	32526		G	0	0				
Cordova Park Elementary	7	2250 SEMUR ROAD	PENSACOLA	32503	N	G	227	4,536			L	per ehpa list
Ernest Ward Middle School <sup>l</sup>		7650 Highway 97	Walnut Hill	32568	R	G	0	0				
Escambia Wesgate Center	6	10050 Ashton Brosnahan	Pensacola	32534	R	G	400	8,000		0	1588-2006	shutters complete July 2007
Escambia Wesgate Center	1-Class Add	10052 Ashton Brosnahan	Pensacola	32536	N	G	0	0				per ehpa list
Escambia Wesgate Center		10051 Ashton Brosnahan	Pensacola	32535		G	0	0				
Ferrypass Elementary	5	8310 North Davis	Pensacola	32514	R	G	293	5,717			S-1435A-2003	
Ferrypass Middle	4	8355 Yancey Ave	Pensacola	32514	R	G	311	6,211		311	S-1435A-2003	
First Presbyterian Church		33 East Gregory St	Pensacola	32595		G	0	0				9.21' SLOSH
First United Methodist		6 East Wright St	Pensacola	32501		G	0	0				
Holy Cross Episcopal Church		7979 North 9th Ave	Pensacola	32514		G	0	0				
Holy Spirit Catholic Church		10650 Gulf Beach HWY	Pensacola	32507		G	0	0				
Jim Allen Elementary School <sup>l</sup>	6	1051 Highway 95A	Cantonment	32533	R	G	293	5,077		0	F,S,L -Hmgrp	
Liberty Church		2221 S. Blue Angel Pkwy	Pensacola	32506		G	0	0				
Lipscomb Elementary School <sup>l</sup>	100 wing N	10200 Ashton Brosnahan	Pensacola	32504	R	G	252	5,041		270	F,S,L -Hmgrp	per State study
Lipscomb Elementary School <sup>l</sup>	100 wing S	10200 Ashton Brosnahan	Pensacola	32504	R	G	105	2,102		105	F,S,L -Hmgrp	per State study
Lipscomb Elementary School <sup>l</sup>	200 wing	10200 Ashton Brosnahan	Pensacola	32504	R	G	305	5,049		305	F,S,L -Hmgrp	per State study
Lipscomb Elementary School <sup>l</sup>	300 wing	10200 Ashton Brosnahan	Pensacola	32504	R	G	262	4,085		262	F,S,L -Hmgrp	per State study
Lipscomb Elementary School <sup>l</sup>	400 wing	10200 Ashton Brosnahan	Pensacola	32504	R	G	266	3,990		280	F,S,L -Hmgrp	per State study
Lipscomb Elementary School <sup>l</sup>	500 wing	10200 Ashton Brosnahan	Pensacola	32504	R	G	339	5,990		339	F,S,L -Hmgrp	per State study
Lipscomb Elementary School <sup>l</sup>	600 wing	10200 Ashton Brosnahan	Pensacola	32504	R	G	342	6,598		342	F,S,L -Hmgrp	per State study
Longleaf Elementary	2	2600 Longleaf dr	Pensacola	32526	R	G	392	7,840		392	S-1435A-2003	
Macedonia CME Church		2285 Stacy RD	Pensacola	32533		G	0	0				
Marcus Point Baptist		6205 North "W" St	Pensacola	32535		G	0	0				
Molino Park ES	1	899 Hwy 97	Molino	32577	N	G,A	852	13,651		852	L	
Molino Park ES	2,3,4,5	899 Hwy 97	Molino	32577	R	G,A	1,062	21,240		1,373	State Shelter Program	shuttering complete June 2007

2012 Statewide Emergency Shelter Plan

ESCAMBIA												
Name	Bldg. #	Address	City	Zip	Retrofitted (R) or New Construction (N)	General (G), PSN (P), Pet-Friendly (A)	Total Risk Capacity In People (Meets ARC 4496)	Total Risk Capacity (ft <sup>2</sup> ) (Meets ARC 4496)	Risk Capacity In People (Does not Meet ARC 4496 or Not Yet Surveyed)	Local Planned usage (reported capacity)	Funding Source: Local (L), State (S), Federal (F), and Program Name	Comments
Navy Point Elementary		1050 Gulf Beach Hwy	Pensacola	32507	R	G	170	2,556		0		in evacuation zone 4-5
Northview High School <sup>1</sup>	1	4100 West Highway 4	Century	32525	R		0	27,436		1,260	S-1435A=2003 // S-1508-2005	storefront not protected- rest mitigated.
Pensacola Civic Center	1st/2lfr halls	201 East Gregory St	Pensacola	32501	R	G	0	0	2,829		L	out-too close to surge
Pensacola Junior College <sup>1</sup>	Lou Ross Bldg	1000 College Avenue	Pensacola	32514	R	G	0	0			F, L - Proj Impact	
Pensacola Junior College <sup>1</sup>	Main	1000 College Avenue	Pensacola	32514	R	G	0	0			F,S,L -HMGP	
Pensacola Senior High	5- new gym	500 West Maxwell Street	Pensacola	32501	N	G	746	15,179		728	L	per EHPA list
Ransom Middle School <sup>1</sup>		1000 West Kingsfield	Cantonment	32533	R	G	0	0				
Saufley Field		Saufley Field	Pensacola	32526		G	0	0				
Scenic Heights Elementary School <sup>1</sup>		3801 Cherry Laurel Drive	Pensacola	32514	R	G	0	0				
Scenic Hills Church		1295 E. Nine Mile Rd	Pensacola	32514		G	0	0				
Sherwood Elementary School <sup>1</sup>	10	501 Cherokee Trail	Pensacola	32506	R	G	212	3,643		0	S-1435A-2003	
St. Christopher		3200 North 12th Aven	Pensacola	32503		G	0	0				
Tate High School <sup>1</sup>	39/ café	1771 Tate Road	Cantonment	32514	R	G	514	8,200		514	S-1435A-2003	
Tate HS	38/ gym	1771 Tate Road	Cantonment	32514	R	G	1,300	26,000		1,300	S-1508-2005	shutters
University of West Florida	Bldg 13	11000 University Parkwa	Pensacol	32514		G	389	5,364		389	S-1523-2002	
University of West Florida	X1	11000 University Parkwa	Pensacol	32514	R		2,369	47,380		2,286	S-1588-2006	impact glass completed Dec 2006
Warrington Middle School <sup>1</sup>		450 South Old Corry Road	Pensacola	32507	R	G	0	0				
Washington High School <sup>1</sup>		6000 College Road	Pensacola	32504	R	G	0	0				
West Florida HS- (former Beggs Voc	25	2404 Longleaf Drive	Pensacola	32506	R	P	0	0				See SpNs below
West Florida HS- (former Beggs Voc	26	2404 Longleaf Drive	Pensacola	32506	R	P	0	0				See SpNs below
West Pensacola High Elementary	3	801 North 49th Ave	Pensacola	32506	R	G	215	4,546		0	S-1435A-2003	
Woodham High School <sup>1</sup>		150 East Burgess Road	Pensacola	32504	R	G	0	0				
Workman Middle	7	6299 Ianier Dr	Pensacola	32504	R	G	286	7,150		286	S-1435A-2003	
							0	0				
							0	0				
							0	0				
<b>TOTALS FOR ESCAMBIA COUNTY</b>							<b>15,486</b>	<b>323,529</b>	<b>2,829</b>	<b>14,310</b>		<b>0</b>
<b>Year 2012</b>	<b>Shelter Capacity In People</b>	<b>Shelter Demand In People</b>	<b>Surplus/ Deficit In People</b>	<b>Shelter Capacity (ft2)</b>			<b>Surplus/ Deficit (ft2)</b>	<b>Result</b>				
Storm Category 4/5	15,486	11,209	4,277	323,529			99,349					
<b>Special Needs Storm Shelters</b>												
Name	Bldg #	Address	City	Zip			SpNS Capacity (spaces @ 60sf) (meets ARC 4496)	SpNs Capacity (sf) (meets ARC 4496)	SpNS Capacity (spaces @ 60sf) (does not meet ARC 4496)	Local Planned usage (reported capacity)	Funding Source: Local (L), State (S), Federal (F), and Program Name	Comments
West Florida High School/(GEO STONE)	25& 26	2404 Longleaf Drive	Pensacola	32506	R	P	317	15,358		317		
							0	0				
							0	0				
<b>Year 2012</b>	<b>SpNs Shelter Capacity In Spaces (meets ARC 4496)</b>	<b>SpNs Shelter Demand In Spaces</b>	<b>Surplus/ Deficit In Spaces</b>	<b>SpNs Shelter Capacity (ft2)</b>			<b>Surplus/ Deficit (ft2)</b>	<b>Result</b>				
Storm Category 4/5	317	307	10	19,020			600					

**2012 Statewide Emergency Shelter Plan**

**FLAGLER**

Name	Bldg. #	Address	City	Zip	Retrofitted (R) or New Construction (N)	General (G), PSN (P), Pet-Friendly (A)	Total Risk Capacity In People (Meets ARC 4496)	Total Risk Capacity (ft <sup>2</sup> ) (Meets ARC 4496)	Risk Capacity In People (Does not Meet ARC 4496 or Not Yet Surveyed)	Local Planned usage (reported capacity)	Funding Source: Local (L), State (S), Federal (F), and Program Name	Comments
Beller Terre ES	300	5345 Belle Terre Parkway	Palm Coast	32127		G	202	4,041				AS-IS- interior corridors per study
Beller Terre ES	400	5345 Belle Terre Parkway	Palm Coast	32127		G	180	3,607				AS-IS- interior corridors per study
Beller Terre ES	500	5345 Belle Terre Parkway	Palm Coast	32127		G	368	7,359				EHPA per State study, no surge
Beller Terre ES	600	5345 Belle Terre Parkway	Palm Coast	32127		G	170	3,409				AS-IS- interior corridors per study
Beller Terre ES	700	5345 Belle Terre Parkway	Palm Coast	32127		G	97	1,930				AS-IS- interior corridors per study
Buddy Taylor Middle School	Main	4500 Belle Terre Parkway	Palm Coast	32137	R	G	0	0	2,421		F-HMGP	roof not retrofitted as thought
Indian Trails Elementary School		5055 Belle Terre Parkway	Palm Coast	32137		G	0	0	1,355			
L. E. Wadsworth Elementary School	400	4550 Belle Terre Parkway	Palm Coast	32135	R	G	128	2,798		128	F-HMGP	updated FISH Data
Matanzas HS	3-Gym	3535 Old Kings Road	Palm Coast	32137		G	710	14,203				AS-IS- gym- no windows?
Matanzas HS	4-café	3535 Old Kings Road	Palm Coast	32137		G	235	4,693				EHPA per State study
Old Kings Elementary School		North Old Kings Road	Bunnell	32136		G	0	0				SLOSH 21.1' affected by CAT 1 Storm Also
Palm Coast High School	2	3265 East Highway 100	Bunnell	32110	R	G	697	16,411		697	F-HMGP	1st floor shuttered per report
Palm Coast High School	7	3265 East Highway 100	Bunnell	32110	R	G	556	10,572		556	F-HMGP	2nd floor shuttered per report
Palm Coast High School	8	3265 East Highway 100	Bunnell	32110	R	G	556	10,401		556	F-HMGP	excludes gym area per report
Rymfire ES	6	1425 Rymfire Drive	Palm Coast			N	G,P	1,116	22,325			desktop survey
Rymfire ES	7	1425 Rymfire Drive	Palm Coast			N	G,P	716	14,323			desktop survey
<b>TOTALS FOR FLAGLER COUNTY</b>							<b>5,731</b>	<b>116,072</b>	<b>3,776</b>	<b>1,937</b>		<b>0</b>

Year 2012	Shelter Capacity In People	Shelter Demand In People	Surplus/ Deficit In People	Shelter Capacity (ft <sup>2</sup> )		Surplus/ Deficit (ft <sup>2</sup> )	Result
Storm Category 4/5	5,731	6,493	-762	116,072		-13,788	

**Special Needs Storm Shelters**

Name	Bldg #	Address	City	Zip			SpNS Capacity (spaces @ 60sf) (meets ARC 4496)	SpNs Capacity (sf) (meets ARC 4496)	SpNS Capacity (spaces @ 60sf) (does not meet ARC 4496)	Local Planned usage (reported capacity)	Funding Source: Local (L), State (S), Federal (F), and Program Name	Comments
Rymfire ES (New in late Aug 2006)		1425 Rymfire Drive	Palm Coast			N	P	122	7,296		1,500	
Buddy Taylor MS	main	4500 Belle Terre Parkway	Palm Coast	32137			P	0	0	777	777	roof not retrofitted as thought
<b>Bunnell ES</b>		500 East Howe Street	Bunnell	32110			P	0	0	0		

Year 2012	SpNs Shelter Capacity In Spaces (meets ARC 4496)	SpNs Shelter Demand In Spaces	Surplus/ Deficit In Spaces	SpNs Shelter Capacity (ft <sup>2</sup> )		Surplus/ Deficit (ft <sup>2</sup> )	Result
Storm Category 4/5	122	354	-232	7,320		-13,920	

**2012 Statewide Emergency Shelter Plan**

**FRANKLIN**

Name	Bldg. #	Address	City	Zip	Retrofitted (R) or New Construction (N)	General (G), PSN (P), Pet-Friendly (A)	Total Risk Capacity In People (Meets ARC 4496)	Total Risk Capacity (ft <sup>2</sup> ) (Meets ARC 4496)	Risk Capacity In People (Does not Meet ARC 4496 or Not Yet Surveyed)	local planned usage	Funding Source: Local (L), State (S), Federal (F), and Program Name	Comments
Apalachicola High School		190 14th St	Apalachicola	32320			0	0	350			0
Brown Elementary School		85 School Road	Eastpoint	32328			0	0	300			0
Carabelle High School		1001 Grey Avenue	Carabelle	32322			0	0	300			0
Chapman Elementary School		155 Ave E	Apalachicola	32320			0	0	450			0
Church of God		1400 Tallahassee Street	Carabelle	32322			0	0	60			0
Church of God		379 Ave A	Eastpoint	32328			0	0	100			0
Fellowship Baptist Church		706 Ryan Street	Carabelle	32322			0	0	100			0
First Baptist Church		206 SE Ave A	Carabelle	32322			0	0	180			0
Lanark Community Church		Spring Street	Lanark Village	32323			0	0	75			0
First Baptist Church		447 Ave A	Eastpoint	32328			0	0	100			0
Mormom Church		Prado Street	Apalachicola	32320			0	0	60			0
Mt Zion Baptist Church		98 Ave E	Apalachicola	32320			0	0	100			0
United Methodist Church		102 NE Ave E	Carabelle	32322			0	0	175			0
United Methodist Church			Apalachicola	32320			0	0	60			0
							0	0				
<b>TOTALS FOR FRANKLIN COUNTY</b>							<b>0</b>	<b>0</b>	<b>2,410</b>	<b>0</b>		<b>0</b>

Year 2012	Shelter Capacity In People	Shelter Demand In People	Surplus/ Deficit In People	Shelter Capacity (ft2)	Surplus/ Deficit (ft2)	Result
Storm Category 4/5	0	413	-413	0	-8,260	

**Special Needs Storm Shelters**

Name	Bldg #	Address	City	Zip	SpNS Capacity (spaces @ 60sf) (meets ARC 4496)	SpNs Capacity (sf) (meets ARC 4496)	SpNS Capacity (spaces @ 60sf) (does not meet ARC 4496)	local planned usage	Funding Source: Local (L), State (S), Federal (F), and Program Name	Comments
Uses Regional Shelter										

Year 2012	SpNs Shelter Capacity In Spaces (meets ARC 4496)	SpNs Shelter Demand In Spaces	Surplus/ Deficit In Spaces	SpNs Shelter Capacity (ft2)	Surplus/ Deficit (ft2)	Result
Storm Category 4/5	0	263	-263	0	-15,780	





2012 Statewide Emergency Shelter Plan

GADSDEN

Year 2012	SpNs Shelter Capacity In Spaces (meets ARC)	SpNs Shelter Demand In Spaces	Surplus/ Deficit In Spaces	SpNs Shelter Capacity (ft2)			Surplus/ Deficit (ft2)	Result			
Storm Category 4/5	0	462	-462	0			-27,720				

**2012 Statewide Emergency Shelter Plan**

**GILCHRIST**

Name	Bldg. #	Address	City	Zip	Retrofitted (R) or New Construction (N)	General (G), PSN (P), Pet-Friendly (A)	Total Risk Capacity In People (Meets ARC 4496)	Total Risk Capacity (ft <sup>2</sup> ) (Meets ARC 4496)	Risk Capacity In People (Does not Meet ARC 4496 or Not Yet Surveyed)	Local Planned Usage (reported capacity)	Funding Source: Local (L), State (S), Federal (F), and Program Name	Comments
Bell Elementary School-Cafetorium	5	NW 10th Street	Bell	32619	N & R	G	361	5,413		492	S-1523-2002	03-SR-78-03-31-01-287
Bell High School -Classroom	14	930 South Main Street	Bell	32619	R	G	305	5,405		305	S-1523-2002	Updated FISH Data
Bell High School - Multi-Purpose	16	930 South Main Street	Bell	32619	N & R	G	569	14,223		467	F-HMGP	Updated FISH Data
Trenton High School - Classroom	27	1013 North Main Street	Trenton	32693	R	G	342	6,931		342	F-HMGP	Updated FISH Data
Trenton High School - Classroom	28	1013 North Main Street	Trenton	32963	R	G	450	6,753		455	F-HMGP	Updated FISH Data
Trenton High School - Multi-purpose	30	1013 North Main Street	Trenton	32963	R	G	208	3,127		278	F-HMGP	Updated FISH Data
Trenton High School - New Gym	34	1013 North Main Street	Trenton	32963	N & R	G	499	12,483		432	S-1523-2002	03-SR-78-03-31-01-287
	2	1350SWSR26	Trenton	32693	N & R	G	293	4,394		492	S-1523-2002	03-SR-78-03-31-01-287
							0	0				
<b>TOTALS FOR GILCHRIST COUNTY</b>							<b>3,027</b>	<b>58,729</b>	<b>0</b>	<b>3,263</b>		<b>0</b>
Year 2012	Shelter Capacity In People	Shelter Demand In People	Surplus/Deficit In People	Shelter Capacity (ft2)			Surplus/Deficit (ft2)	Result				
Storm Category 4/5	3,027	936	2,091	58,729			40,009					
<b>Special Needs Storm Shelters</b>												
Name	Bldg #	Address	City	Zip			SpNS Capacity (spaces @ 60sf) (meets ARC 4496)	SpNs Capacity (sf) (meets ARC 4496)	SpNS Capacity (spaces @ 60sf) (does not meet ARC 4496)	Local Planned Usage (reported capacity)	Funding Source: Local (L), State (S), Federal (F), and Program Name	Comments
Bell HS	20	930 South Main Street	Bell	32619	R	P	102	6,115		102		
Year 2012	SpNs Shelter Capacity In Spaces (meets ARC 4496)	SpNs Shelter Demand In Spaces	Surplus/Deficit In Spaces	SpNs Shelter Capacity (ft2)			Surplus/Deficit (ft2)	Result				
Storm Category 4/5	102	70	32	6,120			1,920					

**2012 Statewide Emergency Shelter Plan**

**GLADES**

Name	Bldg. #	Address	City	Zip	Retrofitted (R) or New Construction (N)	General (G), PSN (P), Pet-Friendly (A)	Total Risk Capacity In People (Meets ARC 4496)	Total Risk Capacity (ft <sup>2</sup> ) (Meets ARC 4496)	Risk Capacity In People (Does not Meet ARC 4496 or Not Yet Surveyed)	Local Planned usage (reported capacity)	Funding Source: Local (L), State (S), Federal (F), and Program Name	Comments
1st United Methodist Church		Ave. L & 3rd Street	Moore Haven	33471	R	G	0	0	40	40	L	not surveyed yet
American Legion Hall		1034 Baker's Hwy	Moore Haven	33471	R	G	0	0	50	50	HMGP	Retrofit completed
Buckhead Ridge Community Center I & II		682 Hwy 78 W	Buckhead Ridge	34974		G	0	0	100	100	L	depends on Cat Storm
Buckhead Ridge V.F.W.		29012 E. SR 78	Buckhead Ridge	34974	N	G	0	0	60	60	HMGP	reinforcing walls/upgrade
Doyle Conner Agricultural Center		900 Hwy 27	Moore Haven	33471		G	0	0	500	500	L	depends on Cat storm
Lake Port Community Center		10245 Red Barn Rd NW	Lakeport	33471		G	0	0			L	depends on Cat storm
Maple Grove Baptist Church		120 East State Rd 78 West	Lakeport	33471	N	G	343	5,900		343	L	
Moore Haven Elementary School		401 Terrier Pride Drive SW	Moore Haven	33471		G	0	0	204	160		Completed
Moore Haven High School		700 Terrier Pride Drive SW	Moore Haven	33471		G	0	0				not suitable
Muse Community Center (new)		3897 Loblolly Road	Muse	33935	N	G	65	3,000		46	LS	depends on Cat Storm
Muse Volunteer Fire Dept		SR 720 & Rainbow Blvd	Muse	33935		G	0	0		0	L	not a suitable bldg
Ortona Volunteer Fire Department		3070 Ortona Locks Road	Ortona	33471		G	0	0			L	depends on Cat Storm
Palmdale Community Center		7969 Main street NW	Palmdale	33944		G	0	0			L	depends on Cat Storm
West Glades Elementary School	5	2586 CR 731	Muse	33935	N	G	278	4,165		594		PSN bldg is 300
<b>TOTALS FOR GLADES COUNTY</b>							<b>686</b>	<b>13,065</b>	<b>954</b>	<b>1,893</b>		<b>0</b>

Year 2012	Shelter Capacity In People	Shelter Demand In People	Surplus/Deficit In People	Shelter Capacity (ft2)	Surplus/Deficit (ft2)	Result
Storm Category 4/5	686	1,392	-706	13,065	-14,775	

**Special Needs Storm Shelters**

Name	Bldg #	Address	City	Zip			SpNS Capacity (spaces @ 60sf) (meets ARC 4496)	SpNs Capacity (sf) (meets ARC 4496)	SpNS Capacity (spaces @ 60sf) (does not meet ARC 4496)	Local Planned usage (reported capacity)	Funding Source: Local (L), State (S), Federal (F), and Program Name	Comments
West Glades ES	3	2586 CR 731	Muse	33935	N	P	110	7,455		50		
Muse Community Center (new)		3897 Lobolly Bay Rd	Muse	33935	N	P						backup SPNS

Year 2012	SpNs Shelter Capacity In Spaces (meets ARC 4496)	SpNs Shelter Demand In Spaces	Surplus/Deficit In Spaces	SpNs Shelter Capacity (ft2)	Surplus/Deficit (ft2)	Result
Storm Category 4/5	110	16	94	6,600	5,640	

**2012 Statewide Emergency Shelter Plan**

**GULF**

Name	Bldg. #	Address	City	Zip	Retrofitted (R) or New Construction (N)	General (G), PSN (P), Pet-Friendly (A)	Total Risk Capacity In People <i>(Meets ARC 4496)</i>	Total Risk Capacity (ft <sup>2</sup> ) <i>(Meets ARC 4496)</i>	Risk Capacity In People <i>(Does not Meet ARC 4496 or Not Yet Surveyed)</i>	Local Planned Usage (reported capacity)	Funding Source: Local (L), State (S), Federal (F), and Program Name	Comments
Honeyville Community Center		240 Honeyville Park Drive	Wewahitchka	32465	N	G	232	4,640		232	S-1621X	
Wewahitchka Middle School	16	602 East River Road	Wewahitchka	32465	N	G	228	3,728		228		Updated FISH Data
Wewahitchka Elementary School	lunch room	514 East River Road	Wewahitchka	32465		G	0	0		193		
Wewahitchka High School (2005)	commons Area	754 East River Road	Wewahitchka	32465		G	0	0		120		
<b>TOTALS FOR GULF COUNTY</b>							<b>460</b>	<b>8,368</b>	<b>0</b>	<b>773</b>	<b>0</b>	<b>0</b>
Year 2012	Shelter Capacity In People	Shelter Demand In People	Surplus/ Deficit In People	Shelter Capacity (ft2)			Surplus/ Deficit (ft2)	Result				
Storm Category 4/5	460	506	-46	8,368			-1,752					
<b>Special Needs Storm Shelters</b>												
Name	Bldg #	Address	City	Zip			SpNS Capacity (spaces @ 60sf) (meets ARC 4496)	SpNs Capacity (sf) (meets ARC 4496)	SpNS Capacity (spaces @ 60sf) (does not meet ARC 4496)	local planned usage		
Uses Regional Shelter								0				
Year 2012	SpNs Shelter Capacity In Spaces (meets ARC 4496)	SpNs Shelter Demand In Spaces	Surplus/ Deficit In Spaces	SpNs Shelter Capacity (ft2)			Surplus/ Deficit (ft2)	Result				
Storm Category 4/5	0	214	-214	0			-12,840					

**2012 Statewide Emergency Shelter Plan**

**HAMILTON**

Name	Bldg. #	Address	City	Zip	Retrofitted (R) or New Construction (N)	General (G), PSN (P), Pet-Friendly (A)	Total Risk Capacity In People (Meets ARC 4496)	Total Risk Capacity (ft <sup>2</sup> ) (Meets ARC 4496)	Risk Capacity In People (Does not Meet ARC 4496 or Not Yet Surveyed)	Local Planned usage (reported capacity)	Funding Source: Local (L), State (S), Federal (F), and Program Name	Comments
Central Hamilton Elementary School	8	Route 2, Box 136	Jasper	32052	N & R	G	119	2,080		119	F-HMGP	Updated FISH Data
Greenwood School	15	US 41 North	Jasper	32052	N & R	G	119	2,080		119	F-HMGP	Updated FISH Data
Hamilton County Senior High School	5 class rooms	5683 US HIGHWAY 129 SOUTH	Jasper	32052	N	G	497	9,933			per state study	Updated FISH Data
Hamilton County Senior High School	6 gym	5683 US HIGHWAY 129 SOUTH	Jasper	32052	N	G,A	623	12,461			per state study	Updated FISH Data
Hamilton County Senior High School	7 ROTC	5683 US HIGHWAY 129 SOUTH	Jasper	32052	N	G	0	411			per state study	Removed;updated FISH Data
Hamilton County Senior High School	8 cafeteria	5683 US HIGHWAY 129 SOUTH	Jasper	32052	N	G	0	0			per state study	PSN
North Hamilton Elementray School	20	1291 Florida Street	Jennings	32053	N & R	G	119	2,704		119	F-HMGP	
Stephen Foster Memorial		Robert & Spring Street	White Spring	32096			0	0				
Town of Jennings	EOC/Fire		Jennings		N & R	G	144	2,880		144	S-EMPA	02CP-04-03-34-02-214
VFW Post 8095		Hwy 6 East	Jasper	32052		G	0	0				
							0	0				
<b>TOTALS FOR HAMILTON COUNTY</b>							<b>1,621</b>	<b>32,549</b>		<b>501</b>		<b>0</b>
Year 2012	Shelter Capacity In People	Shelter Demand In People	Surplus/ Deficit In People	Shelter Capacity (ft2)			Surplus/ Deficit (ft2)	Result				
Storm Category 4/5	1,621	921	700	32,549			14,129					
Special Needs Storm Shelters												
Name	Bldg #	Address	City	Zip			SpNS Capacity (spaces @ 60sf) (meets ARC 4496)	SpNs Capacity (sf) (meets ARC 4496)	SpNS Capacity (spaces @ 60sf) (does not meet ARC 4496)	Local Planned usage (reported capacity)	Funding Source: Local (L), State (S), Federal (F), and Program Name	Comments
Hamilton County Senior High School	8 cafeteria	5683 US HIGHWAY 129 SOUTH	Jasper	32052	N	P	75	4,555				Updated FISH Data
Suwannee Valley Nursing Center		427 15th Ave NW	Jasper	32052		P	0	0	20	20		
Year 2012	SpNs Shelter Capacity In Spaces (meets ARC 4496)	SpNs Shelter Demand In Spaces	Surplus/ Deficit In Spaces	SpNs Shelter Capacity (ft2)			Surplus/ Deficit (ft2)	Result				
Storm Category 4/5	75	82	-7	4,500			-420					

Updated 11/01/11

**2012 Statewide Emergency Shelter Plan**

**HARDEE**

Name	Bldg. #	Address	City	Zip	Retrofitted (R) or New Construction (N)	General (G), PSN (P), Pet-Friendly (A)	Total Risk Capacity In People (Meets ARC 4496)	Total Risk Capacity (ft <sup>2</sup> ) (Meets ARC 4496)	Risk Capacity In People (Does not Meet ARC 4496 or Not Yet Surveyed)	Local Planned Usage (reported capacity)	Funding Source: Local (L), State (S), Federal (F), and Program Name	Comment
Bowling Elementary School	18	4530South Church Street	Bowling Green	33834	N	G	140	2,103		147	L	
Bowling Green Elementary	1	4530 Church st	Bowling Green	33834	N	G	776	13,511		776	L	updated FISH Data
Faith Presbyterian Church		114 N 7th Avenue	Wauchula	33873		G	0	0				
First Baptist Church of Wauchula		1570 W Main Street	Wauchula	33873		G	0	0				
Florida Hospital Wauchula		533 West Carlton Street	Bowling Green	33834		G	0	0				
Hardee Junior High School		300 South Florida Avenue	Wauchula	33873		G	4,418	88,350			L	need local input
Hardee Pet Friendly Shelter		300 S. Florida Ave	Wauchula	33873		A	0	0		150		Not ARC 4496
North Wauchula Elementary School	3	1120 North Florida Avenue	Wauchula	33873	N	G	139	2,082		147	L	
South Florida Comm. College		2968 US17N	Bowling Green	33834	N	P	0	0			L	SPNS shelter
Wauchual ES	ESE/ 500	400 South Florida Avenue	Wauchula	33873		G	0	0	2,988			
Wauchula ES	Media/ 600	400 South Florida Avenue	Wauchula	33873		G	0	0	149			Removed; updated FISH Data
Zolfo Springs Media Center		2915 Schoolhouse Road	Zolfo Springs	33890	R	G	0	0				Removed; updated FISH Data
Zolfo Springs Elementary School	10	3215 Schoolhouse Road	Zolfo Springs	33890	N	G	220	3,870		220	L	updated FISH Data
<b>TOTALS FOR HARDEE COUNTY</b>							<b>5,693</b>	<b>109,916</b>	<b>3,537</b>	<b>1,440</b>		<b>0</b>

Year 2012	Shelter Capacity In People	Shelter Demand In People	Surplus/ Deficit In People	Shelter Capacity (ft2)	Surplus/ Deficit (ft2)	Result
Storm Category 4/5	5,693	2,167	3,526	109,916	66,576	

**Special Needs Storm Shelters**

Name	Bldg #	Address	City	Zip			SpNS Capacity (spaces @ 60sf) (meets ARC 4496)	SpNs Capacity (sf) (meets ARC 4496)	SpNS Capacity (spaces @ 60sf) (does not meet ARC 4496)	Local Planned Usage (reported capacity)	Funding Source: Local (L), State (S), Federal (F), and Program Name	Comment
South Florida Comm. College	1st floor,209-211	2968 US17N	Bowling Green	33834	N	P	110	4,500		110		
Year 2012	SpNs Shelter Capacity In Spaces (meets ARC 4496)	SpNs Shelter Demand In Spaces	Surplus/ Deficit In Spaces	SpNs Shelter Capacity (ft2)	Surplus/ Deficit (ft2)	Result						
Storm Category 4/5	110	284	-174	6,600	-10,440							

**2012 Statewide Emergency Shelter Plan**

**HENDRY**

Name	Bldg. #	Address	City	Zip	Retrofitted (R) or New Construction (N)	General (G), PSN (P), Pet-Friendly (A)	Total Risk Capacity In People (Meets ARC 4496)	Total Risk Capacity (ft <sup>2</sup> ) (Meets ARC 4496) <sup>1</sup>	Risk Capacity In People (Does not Meet ARC 4496 or Not Yet Surveyed)	Local Planned usage (reported capacity)	Funding Source: Local (L), State (S), Federal (F), and Program Name	Comments
Clewiston Central ES	Café	1000 South Dean Duff Ave	Clewiston	33440	R	G	0	0	365			
Clewiston Eastside ES		201 West Arroyo Avenue	Clewiston	33440		G	0	0				
Clewiston HS	8	1501 South Francisco	Clewiston	33440	R	G	0	0	617			New FISH Data
Clewiston HS	10	1501 South Francisco	Clewiston	33440	R	G	0	0	200			New FISH Data
Clewiston HS	1	1501 South Francisco Street	Clewiston	33440	R	G	333	6,231		333	S-1467-2004	dike issues?
Clewiston HS	900	1501 South Francisco Street	Clewiston	33440	R	G	259	4,864		259	S-1467-2004	dike issues?
Clewiston MS	27	601 West Osceola	Clewiston	33440	R	G	0	0	308			New FISH Data
Clewiston MS	30	601 West Osceola Avenue	Clewiston	33440	R	G	166	2,972		166	S-1467-2004	dike issues?
Clewiston MS	31/Gym/Bldg5	601 West Osceola Avenue	Clewiston	33440	R	G	538	11,487		538	S-1467-2004	dike issues? NEW FISH
Clewiston MS	32	601 West Osceola Avenue	Clewiston	33440	R	G	467	7,002		468	S-1467-2004	dike issues? NEW FISH
Clewiston MS	33	601 West Osceola Avenue	Clewiston	33440	R	G	210	3,144		241	S-1467-2004	dike issues? NEW FISH
Clewiston MS	34	601 West Osceola Avenue	Clewiston	33440	R	G	209	3,131		241	S-1467-2004	dike issues? NEW FISH
Clewiston MS	Gym	601 West Osceola	Clewiston	33440	N	G	500	11,314		500	L	Per Master List
John Boy Auditorium	BeardslyRm	1300 South WC Owens Ave	Clewiston	33440	R	G	78	1,564		0		per Shelter Study
LaBelle Civic Center		400 Hickpochee Avenue	LaBelle	33935		G	0	0	313			
LaBelle ES	5	West Cowboy Way	LaBelle	33935	R	G	0	0	282			
LaBelle HS	2	4050 East Cowboy Way	LaBelle	33935	R	G	0	0	282			
LaBelle HS	3	4050 East Cowboy Way	LaBelle	33935	N	G	0	0	371			
LaBelle MS	5-Gym	West Cowboy Way	LaBelle	33935	N	G	500	10,532		500	L	
Labelle MS	1	8000 East Cowboy Way	Labelle	33935	R	G	201	3,012		215	S-1467-2004	New FISH Data
Labelle MS	2	8000 East Cowboy Way	Labelle	33935	R	G	161	2,413		172	S-1467-2004	New FISH Data
Labelle MS	3	8000 East Cowboy Way	Labelle	33935	R	G	442	9,544		442	S-1467-2004	New FISH Data
Labelle MS	4	8000 East Cowboy Way	Labelle	33935	R	G	334	5,730		334	S-1467-2004	New FISH Data
Labelle MS	6	8000 East Cowboy Way	Labelle	33935	R	G	474	7,107		481	S-1467-2004	New FISH Data
Seminole Tribe of Florida	1				N	G	484	9,680		484	L	use only with prior agreement/tribe
Seminole Tribe of Florida	2				N	G	262	5,240		262	L	use only with prior agreement/tribe
Seminole Tribe of Florida	3				N	G	193	3,860		193	L	use only with prior agreement/tribe
Upthegrove ES	23	280 North Main Street	Labelle	33935	R	G	368	7,360		368	S-1467-2004	
VFW Post 10100		SR29	LaBelle	33935	R	G	84	1,680		0		per Shelter Study
<b>TOTALS FOR HENDRY COUNTY</b>							<b>6,263</b>	<b>117,867</b>	<b>3,649</b>	<b>6,197</b>		<b>0</b>
<b>Year 2012</b>	<b>Shelter Capacity In People</b>	<b>Shelter Demand In People</b>	<b>Surplus/ Deficit In People</b>	<b>Shelter Capacity (ft2)</b>			<b>Surplus/ Deficit (ft2)</b>	<b>Result</b>				
Storm Category 4/5	6,263	3,721	2,542	117,867			43,447					
<b>Special Needs Storm Shelters</b>												
Name	Bldg #	Address	City	Zip			SpNS Capacity (spaces @ 60sf) (meets ARC 4496)	SpNs Capacity (sf) (meets ARC 4496)	SpNS Capacity (spaces @ 60sf) (does not meet ARC 4496)	Local Planned usage (reported capacity)	Funding Source: Local (L), State (S), Federal (F), and Program Name	Comments
West Glades ES (Glades County)		2500 S. CR731	LaBelle	33935		P				75		combined with Glades in West Glades



2012 Statewide Emergency Shelter Plan

HENDRY

Year 2012	SpNs Shelter Capacity In Spaces (meets ARC 4496)	SpNs Shelter Demand In Spaces	Surplus/ Deficit In Spaces	SpNs Shelter Capacity (ft2)	Surplus/ Deficit (ft2)	Result
Storm Category 4/5	0	225	-225	0	-13,500	



**2012 Statewide Emergency Shelter Plan**

**HERNANDO**

Name	Bldg #	Address	City	Zip			SpNS Capacity (spaces @ 60sf) (meets ARC 4496)	SpNs Capacity (sf) (meets ARC 4496)	SpNS Capacity (spaces @ 60sf) (does not meet ARC 4496)	Local Planned Usage (reported capacity)	Funding Source: Local (L), State (S), Federal (F), and Program Name	Comments
Challenger K-12	1 (1st floor)	13400 Elgin Boulevard	Spring Hill	34609-0401	N	p	265	15,900		265	L	SF based on LPU, no surge
Brooksville Enrichment Center		99 Jerome Brown Pl	Brooksville	34601	R	P	80	4,800	0			
West Hernando Middle School	6	14325 Ken Austin Parkway	Brooksville	34613	N	p	358	7,169		178		Per FISH, retrofits not verified
ARC Nature Coast Education Center	1	5283 Neff Lake Road	Brooksville	34601	N	p	66	3,960		66		per County
West Hernando Middle School	8	14325 Ken Austin Parkway	Brooksville	34613	N	p	645	12,897		213		Per FISH, retrofits not verified
Year 2012	SpNs Shelter Capacity In Spaces (meets ARC 4496)	SpNs Shelter Demand In Spaces	Surplus/ Deficit In Spaces	SpNs Shelter Capacity (ft2)			Surplus/ Deficit (ft2)	Result				
Storm Category 4/5	1,414	43	1,371	84,840			82,260					

updated 11/01/11

**2012 Statewide Emergency Shelter Plan**

**HIGHLANDS**

Name	Bldg. #	Address	City	Zip	Retrofitted (R) or New Construction (N)	General (G), PSN (P), Pet-Friendly (A)	Total Risk Capacity In People (Meets ARC 4496)	Total Risk Capacity (ft <sup>2</sup> ) (Meets ARC 4496)	Risk Capacity In People (Does not Meet ARC 4496 or Not Yet Surveyed)	Local Planned Usage (reported capacity)	Funding Source: Local (L), State (S), Federal (F), and Program Name	Comments
Agri-Civic Center		4505 George Blvd	Sebring			G	0	0	0		L	not surveyed, but shuttered
Apostolic Church of Jesus		956 Carolina Avenue	Avon Park	33825		G	0	0	0			
Avon Elementary School Cafeteria	10-Cafeteria	705 West Winthrop	Avon Park	33825	N	G	249	4,494	249	249	L	impact glass?
Avon Park High School	6-Cafeteria	700 East Main Street	Avon Park	33825	R	G	0	0	0	300	1508-2005	shuttered per county-what gauge?
Avon Park Middle School	5	South Lake Avenue	Avon Park	33825	N	G	670	12,697	670	670	L	per ehpa list;NewFISH Data
Avon Park High School	10	700 East Main Street	Avon Park	33825	N	G	567	11,334	567			per ehpa list
Avon Park Public Works		221 US 27 South	Avon Park	33825	N	G	365	8,600	365	365	S,L	
Avon Park Recreation		207 East State St	Avon Park	33825	N	G	554	13,040	554	554	S,L	
Cracker Trail Elementary School	4	8200 Sparta Road	Sebring	33870	R	G	200	4,418	200	200	1508-2005	shuttered per county;FISH Data
Fred Wild Elementary School cafeteria	13-cafeteria	1910 South Highlands Ave	Sebring	33870	N	G	249	4,820	249	249	L	need to confirm window protection
Hill/ Gustaf Middle School	9	4700 Schumacher Road	Sebring	33870		G	738	11,077	738	750	L	per ehpa list;NewFISH Data
Lake Placid Elementary School	6	101 Green Dragon Drive	Lake Placid	33852	N	G	225	5,633	225	200	L	New FISH Data
Lake Placid Senior High	2	202 GREEN DRAGON DR	LAKE PLACID	33852	N	G	205	4,105	205			per ehpa list
Lake Placid Middle School	9	201 S TANGERINE DRIVE	LAKE PLACID	33852	N	G	197	3,946	197			per ehpa list;NewFISH Data
Memorial ES	Cafeteria/bldg 2	867 Memorial Drive	Avon Park	33825	N	G	235	6,318	235	235	L	needs Verification
Memorial ES	1	868 Memorial Drive	Avon Park	33826	N	G	543	10,850	543			per ehpa list;needs Verification
Sebring High School	8	3514 Kenilworth Boulevard	Sebring	33870	N	G	220	4,660	220	220	L	no windows;New FISH
Sebring High School	13	3514 KENILWORTH BOUL	SEBRING	33870	N	G	750	12,345	750	750	L	per ehpa list;NewFISH Data
Sebring Middle School		500 East Center	Sebring	33870		G	0	0	0			Newest bldg. yr 1979 per FISH?
Skate Center		125 Commerce	Lake Placid	33852		G	0	0	0			
South Florida Community College	Bldg a	600 West College Dr	Avon Park	33825	N	G	217	6,680	217	217	S-1395B	
St. Johns United Methodist Church		3214 Grand Prix Drive	Sebring	33872		G	0	0	0			
Sun'N Lake Elementary School		4515 Ponce De Leon	Sebring	33870		G	0	0	0			Bldg.#4 4,142 sqft; FISH Data
Temple Israel of Highlands County		1305 Hillside Drive	Sebring	33870		G	0	0	0			
The Elks - Lake Placid		200 CR 621 East	Lake Placid	33852		G	0	0	0			
Walker Memorial Seventh Day Adventist		1410 West Avon Boulevard	Avon Park	33825		G	0	0	0			
Woodlawn Elementary School Cafeteria	2	718 Fielder Boulevard	Sebring	33870	N	G	249	4,626	249	249	L	New FISH Data

**TOTALS FOR HIGHLANDS COUNTY**      6,433      129,643      6,433      5,208      0

Year 2012	Shelter Capacity In People	Shelter Demand In People	Surplus/ Deficit In People	Shelter Capacity (ft <sup>2</sup> )	Surplus/ Deficit (ft <sup>2</sup> )	Result
Storm Category 4/5	6,433	8,104	-1,671	129,643	-32,437	

**Special Needs Storm Shelters**

Name	Bldg #	Address	City	Zip	SpNS Capacity (spaces @ 60sf) (meets ARC 4496)	SpNs Capacity (sf) (meets ARC 4496)	SpNS Capacity (spaces @ 60sf) (does not meet ARC 4496)	Local Planned Usage (reported capacity)	Funding Source: Local (L), State (S), Federal (F), and Program Name	Comments
Highlands Agri-Civic Center		4505 George Blvd	Sebring		P	75	4,500	42	122	not surveyed but shuttered
Sebring CivicCenter			Sebring		P	465	28,000			s-1621X

Year 2012	SpNs Shelter Capacity In Spaces (meets ARC 4496)	SpNs Shelter Demand In Spaces	Surplus/ Deficit In Spaces	SpNs Shelter Capacity (ft <sup>2</sup> )	Surplus/ Deficit (ft <sup>2</sup> )	Result
Storm Category 4/5	540	262	278	32,400	16,680	

2012 Statewide Emergency Shelter Plan

HILLSBOROUGH

Name	Bldg. #	Address	City	Zip	Retrofitted (R) or New Construction (N)	General (G), PSN (P), Pet-Friendly (A)	Total Risk Capacity In People (Meets ARC 4496)	Total Risk Capacity (ft <sup>2</sup> ) (Meets ARC 4496)	Risk Capacity In People (Does not Meet ARC 4496 or Not Yet Surveyed)	Local Planned Usage (reported capacity)	Funding Source: Local (L), State (S), Federal (F), and Program Name	Comments
Adams Middle (EHPA)	11	10201 N. Boulevard	Tampa	33612	N	G	181	3,628		181	LS	
Adams Middle (EHPA)	7/Gym	10201 N. Boulevard	Tampa	33612	N	G	465	9,300		465	L,S	
Armwood HS (EHPA)	CFK	12000 US Hwy 92	Seffner	33584	N	G	800	16,000		800	L,S	
Barrington Middle (EHPA)		Fish Hawk Creek Area	Lithia	33547	N	G	1,500	30,000		1,500	L,S	
Bartels Middle (EHPA)	3,4	9020 Imperial Oaks Blvd	Tampa	33614	N	G	1,800	36,000		1,800	L,S	
Bartels Middle (EHPA)	CFK	9020 Imperial Oaks Blvd	Tampa	33647	N	G,A	540	10,800		540	L,S	
Bellamy Elementary (EHPA)	3	9720 Wilsky Blvd	Tampa	33615	N	G	0	0		500	L,S	2.7' SLOSH
Benito Elementary	2,3,6	10101 Cross Creek Blvd	Tampa	33647	R	G	1,811	36,220		1,811	HMGP	
Benito Elementary (EHPA)	CFK	10101 Cross Creek Blvd	Tampa	33647	N	G	400	8,000		400	L,S	
Bevis Elementary (EHPA)	2	5720 Osprey Ridge Dr	Lithia	33547	N	G	411	8,220		411	L,S	
Bevis Elementary (EHPA)	3	5720 Osprey Ridge Dr	Lithia	33547	N	G	411	8,220		411	L,S	
Bloomingdale High	13	1700 E. Bloomingdale Ave	Valrico	33594	R	G	828	16,560		828	S-1523	
Boyette Springs ES (EHPA)	16	10141 Sedgebrook Dr	Riverview	33569	N	G	500	10,000		500	L,S	
Brandon HS (EHPA)	New Addition	1101 Victoria ST	Brandon	33510	N	G	800	16,000		800	LS	2006-2007
Brooker Elementary (EHPA)	CFK (Clstrm for Kids)	812 DeWolf Rd	Brandon	33511	N	G	500	10,000		500	L,S	
Bryant Elementary	CFK	13910 Nine Eagles Rd	Tampa	33626	N	G	0	0		800	L,S	4.2' SLOSH
Bryant Elementary (EHPA)	2,3	13910 Nine Eagles Rd	Tampa	33626	N	G	0	0		1,169	L,S	4.2' SLOSH
Burnett Middle	1,2,3	1010 N. Kingsway Rd	Seffner	33584	R	G	1,328	26,560		1,328	HMGP	
Burnett Middle (EHPA)	CFK	1010 N. Kingsway Rd	Seffner	33584	N	G	340	6,800		340	L,S	
Canella Elementary (EHPA)	13	10707 Nixon Rd	Tampa	33624	N	G	500	10,000		500	L,S	
Carrollwood ES	18	3516 MACFARLAND ROAD	Tampa	33618	N	G	470	3,052		470		
Carver Center (EHPA)	2	2934 E. Hillsborough Ave	Tampa	33610	N	G	600	12,000		600	L,S	
Chiles Elementary (EHPA)	2	16541 Tampa Palms Blvd	Tampa	33647	N	G	729	14,580		729	L,S	
Chiles Elementary (EHPA)	3	16541 Tampa Palms Blvd	Tampa	33647	N	G	729	14,580		729	L,S	
Chiles Elementary (EHPA)	CFK (Clstrm for Kids)	16541 W. Tampa Palms Blvd	Tampa	33647	N	G	500	10,000		500	LS	2006-2007
Cimino Elementary	CFK (Clstrm for Kids)	4329 Culbreath Rd	Valrico	33594	N	G	500	10,000		500	L,S	
Cimino Elementary (EHPA)	2	4329 Culbreath Rd	Valrico	33594	N	G	1,556	31,120		1,556	L,S	
Collins ES (EHPA)	3	12424 SUMMERFIELD BOULEVARD	Riverview	33569	N	G	1,968	39,357		1,968		
Cork Elementary (EHPA)	CFK (Clstrm for Kids)	3501 N. Cork Rd	Plant City	33565	N	G	500	10,000		500	L,S	
Corr Elementary (EHPA)	3,4	13020 Kings Lake Dr	Gibsonton	33534	N	G	0	0		890	L,S	4.7' SLOSH
Crestwood Elementary (EHPA)	CFK (Clstrm for Kids)	7824 N. Manhattan Ave	Tampa	33614	N	G	500	10,000		500	L,S	
Crestwood ES	13	7824 N. Manhattan Ave	Tampa	33614	R	G	995	19,900		995	S-1435A-2003	
Cypress Creek Elementary (EHPA)	CFK	4040 19th Ave N.E.	Ruskin	33570	N	G	540	10,800		540	L,S	
Deer Park ES (EHPA)	New School	11605 Citrus Park Dr	Tampa	33625	N	G	0	0		1,000	LS	2006-2007, 3.6' SLOSH
Doby Elementary (EHPA)	2,3	6720 Covington Garden Dr	Apollo Beach	33572	N	G	1,600	32,000		1,600	L,S	
Durant High	1,2,3,4,5,6,7	4748 Cougar Path	Plant City	33567	R	G	2,116	42,320		2,116	HMGP	
Durant High	New Addition	4748 Cougar Path	Plant City	33567	N	G	800	16,000		800	LS	2006-2007
Edison Elementary	5	1607 E. Curtis St	Tampa	33610	R	G	0	0		0	not done in	Cancelled
Edison Elementary	6	1607 E. Curtis St	Tampa	33610	R	G	0	0		0	not done in	Cancelled
Eisenhower Middle (EHPA)	5-Gym	7620 Big Bend Rd	Gibsonton	33534	N	G	485	9,700		485	L,S	
Eisenhower MS	2				R	G	0	0		0	not done in S-1508-2005	Cancelled
Eisenhower MS	5				R	G	0	0		0	not done in S-1508-2005	Cancelled
Essrig Elementary	10	13031 Lynn Rd	Tampa	33624	N	G	441	8,820		441	L,S	
Fish Hawk Elementary (EHPA)	2	16815 Dorman Rd	Lithia	33547	N	G	725	14,500		725	L,S	
Fish Hawk Elementary (EHPA)	3	16815 Dorman Rd	Lithia	33547	N	G	725	14,500		725	L,S	
Forest Hills Elementary	ESE	10112 N. Ola Ave	Tampa	33612	R	G	646	12,920		646	S-1467-2004	
Forest Hills Elementary	Music	10112 N. Ola Ave	Tampa	33612	R	G	0	0		0	not done in S-1467-2004	Cancelled
Forest Hills Elementary (EHPA)	CFK (Clstrm for Kids)	10112 N. Ola Ave	Tampa	33612	N	G	500	10,000		500	L,S	
Freedom High	3	17410 Commerce Park Blvd	Tampa	33647	R	G	0	0		0	not done in S-1467-2004	Cancelled
Freedom High	6	17410 Commerce Park Blvd	Tampa	33647	R	G	0	0		0	not done in S-1467-2004	Cancelled

2012 Statewide Emergency Shelter Plan

HILLSBOROUGH

Name	Bldg. #	Address	City	Zip	Retrofit ed (R) or New Constru ction (N)	General (G), PSN (P), Pet - Friendly (A)	Total Risk Capacity In People (Meets ARC 4496)	Total Risk Capacity (ft <sup>2</sup> ) (Meets ARC 4496)	Risk Capacity In People (Does not Meet ARC 4496 or Not Yet Surveyed)	Local Planned Usage (reported capacity)	Funding Source: Local (L), State (S), Federal (F), and Program Name	Comments
Freedom High	9	17410 Commerce Park Blvd	Tampa	33647	R	G	0	0		0	not done in S-1467-2004	Cancelled
Freedom High	10	17410 Commerce Park Blvd	Tampa	33647	R	G	0	0		0	not done in S-1467-2004	Cancelled
Frost ES	3	3950 SOUTH FAULKENBURG ROAD	RIVERVIEW	33569	N	G	0	0		356		7.8' SLOSH
Frost ES	4	3950 SOUTH FAULKENBURG ROAD	RIVERVIEW	33569	N	G	0	0		422		7.8' SLOSH
GIUNTA MIDDLE SCHOOL	1	4202 SOUTH FAULKENBURG ROAD	Riverview	33569	N	G	0	0		3,537		6.8' SLOSH
Greco Middle (EHPA)	Gym	6925 E. Fowler	Temple Terrace	33617	N	G	437	8,740		800	L.S.	
Hillsborough Comm College at the Regent	1	6437 Watson Rd	Riverview	33578	N	P	0	0		0		see PSN Below
Hammonds ES	New School	8008 N. Mobley RD	Odessa	33556	N	G	1,200	24,000		1,200	L.S.	2006-2007
Heritage Elementary (EHPA)	3,4	10900 Cross Creek Blvd	Tampa	33647	N	G	1,535	30,700		1,535	L.S.	
Ippolito Elementary (EHPA)	2,3	6874 S. Falkenburg Rd	Riverview	33569	N	G	0	0		1,458	L.S.	8.7' SLOSH
Jennings Middle (EHPA)	3,4	8799 Williams Rd	Seffner	33584	N	G	2,049	40,980		2,049	L.S.	
Kingswood Elementary (EHPA)	CFK (Clism for Kids)	3102 S. Kings Ave	Brandon	33511	N	G	500	10,000		500	L.S.	
Knights Elementary (EHPA)	CFK (Clism for Kids)	4815 N. Keene Rd	Plant City	33565	N	G	500	10,000		500	L.S.	
Lake Magdalene ES (EHPA)	CFK (Clism for Kids)	2002 Pine Lake Dr	Tampa	33612		G	500	10,000		500	L.S.	
Lake Magdelene ES	14	2002 Pine Lake Dr	Tampa	33612	R	G	455	9,100		455	S-1435A-2003	
Lennard HS (EHPA)	2	2002 SHELL POINT ROAD	Ruskin	33570	N	G	0	0		256		2.5' SLOSH
Lennard HS (EHPA)	7	2002 SHELL POINT ROAD	Ruskin	33570	N	G	0	0		415		2.5' SLOSH
Lennard HS (EHPA)	8	2002 SHELL POINT ROAD	Ruskin	33570	N	G	0	0		269		2.5' SLOSH
Lewis Elementary	9	6700 E. Whiteway Dr	Temple Terrace	33617	R	G	297	5,940		297	S-1467-2004	
Liberty Middle	7	17400 Commercr Park Blvd	Tampa	33647	R	G	0	0		0	not done in S-1467-2004	Cancelled
Limona ES	9	1115 TelFair	Brandon	33550	R	G	184	3,680		184	S-1435A-2003	
Lockhart Elementary	2	3719 N. 17th St	Tampa	33610	R	G	0	0		0	not done in S-1435A-2003	Decommissioned, escape sreens falling off
Lockhart Elementary	5	3719 N. 17th St	Tampa	33610	R	G	1,474	29,480		408	S-1435A-2003	
Lomax Elementary (EHPA)	4	4207 N. 26th St	Tampa	33610	N	G	465	9,300		465	L.S.	
Mann MS	Gym				R	G	0	0		0	not done in S-1508-2005	Cancelled
Marshall Middle	13	18 S. Maryland Ave	Plant City	33563	R	G	225	4,500		225	S-1523	
Marshall Middle (EHPA)	CFK	18 S. Maryland Ave	Plant City	33563	N	G	400	8,000		400	L.S.	
Martinez Middle	3	5601 Lutz Lake Fern Rd	Lutz	33558	R	G	948	18,960		948	S-1467-2004	
Martinez Middle	4	5601 Lutz Lake Fern Rd	Lutz	33558	R	G	958	19,160		958	S-1467-2004	
McClane MS	Gym				R	G	0	0		0	not done in S-1508-2005	Cancelled
McKitrick Elementary (EHPA)	2,3	5503 Lutz Lake Fern Rd	Lutz	33549	N	G	1,451	29,020		1,451	L.S.	
McKitrick Elementary (EHPA)	CFK (Clism for Kids)	5503 Lutz Lake fern rd	Lutz	33549	N	G	800	16,000		800	L.S.	
McLane MS	20	306 N. Knight	Brandon	33610	R	G	1,071	21,420		1,071	S-1435A-2003	
Memorial Middle	Gym	4702 N. Cent	Tampa	33603	R	G	465	9,300		800	S-1523 / S-1435A	
Mendenhall Elementary (EHPA)	CFK (Clism for Kids)	5202 Mendenhall Dr	Tampa	33603	N	G	0	0		500	L.S.	4.1' SLOSH
Middleton High (EHPA)	2,3	4801 North 22nd Street	Tampa	33610	N	G	2,298	45,960		2,298	L.S.	
Mort Elementary	4	1806 E. Bearss Ave	Tampa	33613	R	G	0	0		0	not done in S-1467-2004	Cancelled
Mort Elementary (EHPA)	CFK (Clism for Kids)	1806 E. Bearss Ave	Tampa	33613	N	G	500	10,000		500	L.S.	
Muller Elementary (EHPA)	4	13615 N. 22nd St	Tampa	33613	N	G	310	6,200		310	L.S.	
Mulrennan Middle (EHPA)	2,4,6	4215 Durant Rd	Valrico	33594	N	G	2,250	45,000		2,250	L.S.	

2012 Statewide Emergency Shelter Plan

HILLSBOROUGH

Name	Bldg. #	Address	City	Zip	Retrofit ed (R) or New Constru ction (N)	General (G), PSN (P), Pet - Friendly (A)	Total Risk Capacity In People (Meets ARC 4496)	Total Risk Capacity (ft <sup>2</sup> ) (Meets ARC 4496)	Risk Capacity In People (Does not Meet ARC 4496 or Not Yet Surveyed)	Local Planned Usage (reported capacity)	Funding Source: Local (L), State (S), Federal (F), and Program Name	Comments
Nelson Elementary (EHPA)	2,3	5413 Durant Rd	Dover	33527	N	G	1,610	32,200		1,610	LS	
Nelson Elementary (EHPA)	CFK	5413 Durant Rd	Dover	33527	N	G	540	10,800		540	LS	
Newsome High (EHPA)	2,7,8	16550 Fish Hawk Blvd	Lithia	33547	N	G	1,586	31,720		1,586	LS	
Oak Park ES (EHPA)	New School	4322 E. Ellicott ST	Tampa	33610	N	G	1,000	20,000		1,000	LS	2006-2007
Pizzo Elementary	2,3,4	11701 Bull Run Rd	Tampa	33617	R	G	1,595	31,900		1,595	S-1523	
Plant City High	13	1 Raider Pl	Plant City	33566	R	G	399	7,980		399	S-1523	
Potter Elementary	11	3224 E. Cayuga St	Tampa	33610	R	G	253	5,060		253	S-1467-2004	
Potter Elementary	13	3224 E. Cayuga St	Tampa	33610	R	G	253	5,060		253	S-1467-2004	
Pride Elementary (EHPA)	3,4	18271 Kinnan St	Tampa	33647	N	G	1,114	22,280		1,114	LS	
Pride Elementary (EHPA)	CFK	10310 Lions Den Dr	Tampa	33647	N	G	400	8,000		400	LS	
Randall Middle	1,3	16510 Fish Hawk Blvd	Lithia	33547	R	G	813	16,260		813	HMGP	
Reddick ES (EHPA)	3,4	325 West Lake Dr	Wimauma	33598	N	G	1,350	27,000		1,350	LS	
Riverview High, Building #10	10	11311 Boyette Rd	Riverview	33569	R	P	350	7,000		350	L S	
Riverview Hs	5	11311 Boyette Rd	Riverview	33569	R	G	0	0		0	HMGP	Never retrofitted
Riverview Hs	10	11311 Boyette Rd	Riverview	33569	R	G	0	0		0	HMGP	Not a G shelter
Robinson ES	12	4801 S. Turkey Creek Rd	Plant City	33567	R	G	404	8,080		563	S-1435A-2003	
Robles ES	15	4405 E. Sligh Ave	Tampa	33610	R	G	351	7,020		351	S-1435A-2003	
Robles ES	16	4405 E. Sligh Ave	Tampa	33610	R	G	171	3,420		171	S-1435A-2003	
Rodgers Middle	1,2,3	11910 Tucker Rd	Riverview	33569	R	G	0	0		0	S-1543 & S1435A	Decommissioned, escape screens falling off
Schmidt Elementary	3	1250 Williams Rd	Brandon	33510	N	G	890	17,800		890	LS	
Sessums Elementary (EHPA)	2,3	11525 Ramble Creek Dr	Riverview	33569	N	G	1,564	31,280		2,099	LS	
Sheehy Elementary (EHPA)	4	N. 40th St	Tampa	33610	N	G	996	19,920		625	LS	
Shields Middle (EHPA)	3	3908 N.E. 19th Ave	Ruskin	33570	N	G	675	13,500		1,025	LS	
Shields Middle (EHPA)	4	3908 N.E. 19th Ave	Ruskin	33570	N	G	675	13,500		1,025	LS	
Shields MS CFK	CFK (EHPA)	3908 N.E. 19th Ave	Ruskin	33573	N	G,A	540	10,800		540	S,L	
Sickles High	3,7	7950 Gunn Hwy	Tampa	33626	R	G	961	19,220		961	S-1543	
Sickles HS CFK	CFK (EHPA)	7950 Gunn Hwy	Tampa	33626	N	G	540	10,800		720	S,L	
Simmons Center (EHPA)	1	901 South Evers St	Plant City	33566	N	G	388	7,760		425	LS	
Sligh MS	15	2011 E. Sligh Ave	Tampa	33610	R	G	312	6,240		589	S-1435A-2003	
Smith Middle (EHPA)	3,4	14303 Citrus Pointe Dr	Tampa	33625	N	G,A	1,350	27,000		1,350	LS	
SPOTO HIGH SCHOOL	3	8538 EAGLE PALM DRIVE	Riverview	33569	N	G	0	0		820		6.7' SLOSH
SPOTO HIGH SCHOOL	4	8538 EAGLE PALM DRIVE	Riverview	33569	N	G	0	0		1,347		6.7' SLOSH
Springhead Elementary (EHPA)	CFK (Clstrm for Kids)	3208 Nesmith Rd	Plant City	33566	N	G	500	10,000		500	LS	
Steinbrenner High (EHPA)		5575 W Lutz Lake Fern Rd	Lutz	33558	N	G	1,500	30,000		1,500	LS	
Stowers Elementary (EHPA)		13915 Barrington Stowers Dr	Lithia	33547	N	G	1,250	25,000		1,250	LS	
Strawberry Crest High (EHPA)		4691 Gallagher Rd	Dover	33527	N	G,A	1,500	30,000		1,500	LS	
Sulphur Springs ES	1	8412 N. 13th St	Tampa	33604	R	G	867	17,340		1,534	S-1435A-2003	
Summerfield Crossings ES (EHPA)	New School	Fairway Meadows Drive	RIVERVIEW	33569	N	G	1,200	24,000		1,200	LS	2006-2007
Summerfield ES CFK	CFK (EHPA)	11990 Big Bend Rd	Riverview	33569	N	G	400	8,000		540	LS	
SYMMESE ELEMENTARY	3	6280 WATSON ROAD	RIVERVIEW	33569	N	G	350	7,002		350		
SYMMESE ELEMENTARY	4	6280 WATSON ROAD	RIVERVIEW	33569	N	G	337	6,749		337		
Tampa Bay Blvd ES (EHPA)	CFK (Clstrm for Kids)	3111 Tampa Bay Blvd	Tampa	33607	N	G	800	16,000		800	LS	
Tampa Bay Blvd. Elementary	3	3111 Tampa Bay Blvd	Tampa	33607	R	G	0	0		0	not done in S-1467-2004	Cancelled
Tampa Bay Blvd. Elementary	4	3111 Tampa Bay Blvd	Tampa	33607	R	G	0	0		0	not done in S-1467-2004	Cancelled
Tampa Bay Blvd. Elementary	6	3111 Tampa Bay Blvd	Tampa	33607	R	G	226	4,520		226	S-1467-2004	
Tampa Palms ES (EHPA)	CFK (Clstrm for Kids)	6100 Tampa Palms Blvd	Tampa	33647	N	G	500	10,000		500	LS	
Temple Terrace ES (EHPA)	CFK (Clstrm for Kids)	124 Flotto Ave	Temple Terrace	33617	N	G	500	10,000		500	LS	2006-2007
Tomlin Middle	10	501 N. Wilson St	Plant City	33563	R	G	439	8,780		439	S-1523	
Tomlin Middle (EHPA)	CFK	501 N. Woodrow Wilson St	Plant City	33567	N	G	540	10,800		540	LS	
Turkey Creek Middle	8	5005 S. Turkey Creek Rd	Plant City	33567	R	G	594	11,880		594	S-1523	

2012 Statewide Emergency Shelter Plan

HILLSBOROUGH

Name	Bldg. #	Address	City	Zip	Retrofitted (R) or New Construction (N)	General (G), PSN (P), Pet-Friendly (A)	Total Risk Capacity In People (Meets ARC 4496)	Total Risk Capacity (ft <sup>2</sup> ) (Meets ARC 4496)	Risk Capacity In People (Does not Meet ARC 4496 or Not Yet Surveyed)	Local Planned Usage (reported capacity)	Funding Source: Local (L), State (S), Federal (F), and Program Name	Comments
Turner ES (EHPA)	2	9190 IMPERIAL OAK BOULEVARD	TAMPA	33614	N	G	349	6,972		349		
Turner ES (EHPA)	3	9190 IMPERIAL OAK BOULEVARD	TAMPA	33614	N	G	340	6,792		340		
USF Sun Dome		4202 E. Fowler Ave	Tampa	33620	R	P	0	0		0	L, S	
Valencia Lakes ES *N*	New School (EHPA)		Wimauma	33598	N	G	0	0		0	S,L	Renamed Reddick ES
Valrico ES	3 (1st flr)	609 S. Miller Rd	Valrico	33594	R	G	423	8,460		423	S-1435A-2003	
Valrico ES	4 (1st flr)	609 S. Miller Rd	Valrico	33594	R	G	480	9,600		480	S-1435A-2003	
Valrico ES CFK	CFK (EHPA)	609 S. Miller Rd	Valrico	33594	N	G	540	10,800		540	S,L	
Walden Lake ES CFK	CFK (EHPA)	2800 S. Turkey Creek Rd	Plant City	33566	N	G	540	10,800		720	S,L	
Walker Middle	2	8282 N. Mobley Rd	Odessa	33556	R	G	932	18,640		1,527	S-1435A-2003	
Walker Middle	3	8282 N. Mobley Rd	Odessa	33556	R	G	300	6,000		300	S-1523	
Wharton High	2,3,4,9	20150 Bruce B. Downs Blvd	Tampa	33647	R	G	0	0			S-1523	Decommissioned, Bats in Fabric, Shutters removed
Wharton HS CFK	CFK (EHPA)	20150 Bruce B. Downs Blvd	Tampa	33647	N	G	540	10,800		720	S,L	
Whitley Bowers Career Center (EHPA)	7 (1?)	13609 N. 22nd St	Tampa	33613	N	G	275	5,500		275	L,S	
Williams MS	2	5020 N. 47th	Tampa	33610	R	G	364	7,280		650	S-1435A-2003	
Wilson ES	3	702 English St	Plant City	33563	R	G	648	12,960		721	S-1435A-2003	
Young MS	8	1807 E. Dr. MLK Blvd	Tampa	33610	R	G	629	12,580		527	S-1435A-2003	
							0	0				
							0	0				
<b>TOTALS FOR HILLSBOROUGH COUNTY</b>							<b>90,955</b>	<b>1,812,752</b>	<b>0</b>	<b>107,862</b>		<b>0</b>
<b>Year 2012</b>	<b>Shelter Capacity In People</b>	<b>Shelter Demand In People</b>	<b>Surplus/ Deficit In People</b>	<b>Shelter Capacity (ft2)</b>			<b>Surplus/ Deficit (ft2)</b>	<b>Result</b>				
Storm Category 4/5	90,955	47,195	43,760	1,812,752			868,852					
<b>Special Needs Storm Shelters</b>												
Name	Bldg #	Address	City	Zip			SpNs Capacity (spaces @ 60sf) (meets ARC 4496)	SpNs Capacity (sf) (meets ARC 4496)	SpNs Capacity (spaces @ 60sf) (does not meet ARC 4496)	Local Planned Usage (reported capacity)	Funding Source: Local (L), State (S), Federal (F), and Program Name	Comments
Hillsborough Comm College at the Regent	1	6437 Watson Rd	Riverview	33578	N	P	230	13,852		230		L,S, HMGP
Erwin Tech		2010 E. Hillsborough Ave	Tampa	33610			0	0	500			
Riverview HS (	10	11311 Boyette Rd	Riverview	33569	N	P	350	21,000		400	L,S	
Riverview HS (EHPA)	CFK	11311 Boyette Rd	Riverview	33569	N	P	400	8,000		400	L,S	Genset being moved from Bldg 10, no surge
TBD 2							0	0				
USF Sun Dome		4202 E. Fowler Ave	Tampa	33620	R	P	1,500	90,000		1,000		
<b>Year 2012</b>	<b>SpNs Shelter Capacity In Spaces (meets ARC 4496)</b>	<b>SpNs Shelter Demand In Spaces</b>	<b>Surplus/ Deficit In Spaces</b>	<b>SpNs Shelter Capacity (ft2)</b>			<b>Surplus/ Deficit (ft2)</b>	<b>Result</b>				
Storm Category 4/5	2,480	2,446	34	148,800			2,040					



2012 Statewide Emergency Shelter Plan

HOLMES

Name	Bldg. #	Address	City	Zip	Retrofitted (R) or New Construction (N)	General (G), PSN (P), Pet - Friendly (A)	Total Risk Capacity In People (Meets ARC 4496)	Total Risk Capacity (ft <sup>2</sup> ) (Meets ARC 4496)	Risk Capacity In People (Does not Meet ARC 4496 or Not Yet Surveyed)	Local Planned Usage (reported capacity)	Funding Source: Local (L), State (S), Federal (F), and Program Name	Comments
Bethlehem High School		2667 Hwy 160	Bonifay	32425			0	0	1,905	1,905		Bldg. #1 44,859 sqft per FISH
Bonifay Middle School		401 McLaghlin Avenue	Bonifay	32425			0	0	356	356		Bldg#5, and #7 83/04?
Holmes County Agricultural Center		Rt 1 Box 408 Hwy 90 E	Bonifay	32425			0	0	0	436		
Holmes High School	1	825 West Hwy 90	Bonifay	32425			0	0	0	942		Bldg#1 44,797 sqft per FISH 1989
New Hope VFD		1243 Hwy 179-A	Westville	32464	R	G	179	3,585		179	L, S, & F (EMPA)	open
Ponce De Leon Elementary School	5	1473 Ammons Road	Ponce de Leon	32455			0	0	0	195		Bldg#5 4,056 sqft per FISH 1993
Ponce De Leon High School - New Gym		1477 Ammons Road	Ponce de Leon	32425			0	0	515	515		built 1988 28,165 sqft per FISH bldg 1
Poplar Springs HS (new)- Classroom	4	3726 Atomic Drive	Graceville	32440			0	0				not EHPA
Poplar Springs HS (new)- Classroom	5	3726 Atomic Drive	Graceville	32440			0	0				not EHPA
Poplar Springs HS (new)- Classroom	6	3726 Atomic Drive	Graceville	32440			0	0				not EHPA
Poplar Springs HS (new)- Gym	3 (non-SpNs)-Gym	3726 Atomic Drive	Graceville	32440	N	G	796	11,942		1,045		part used Spns- rest regular
Poplar Springs HS(new)- Cafeteria	7 - Cafeteria	3726 Atomic Drive	Graceville	32440	N	G	357	5,361		534	L	update per FISH
<b>TOTALS FOR HOLMES COUNTY</b>							<b>1,332</b>	<b>20,888</b>	<b>2,776</b>	<b>6,107</b>		<b>0</b>

Year 2012	Shelter Capacity In People	Shelter Demand In People	Surplus/ Deficit In People	Shelter Capacity (ft2)	Surplus/ Deficit (ft2)	Result
Storm Category 4/5	1,332	1,026	306	20,888	368	

Special Needs Storm Shelters

Name	Bldg #	Address	City	Zip			SpNS Capacity (spaces @ 60sf) (meets ARC 4496)	SpNs Capacity (sf) (meets ARC 4496)	SpNS Capacity (spaces @ 60sf) (does not meet ARC 4496)	Local Planned Usage	Funding Source: Local (L), State (S), Federal (F), and Program Name	Comments
Poplar Springs HS	Gym/3 (part of it)	3726 Atomic Drive	Graceville	32440	N	P	38	2,280		38		Total Bldg. per FISH 14,222 sqft
							0	0				
							0	0				
							0	0				

Year 2012	SpNs Shelter Capacity In Spaces (meets ARC 4496)	SpNs Shelter Demand In Spaces	Surplus/ Deficit In Spaces	SpNs Shelter Capacity (ft2)	Surplus/ Deficit (ft2)	Result
Storm Category 4/5	38	62	-24	2,280	-1,440	

2012 Statewide Emergency Shelter Plan

INDIAN RIVER												
Name	Bldg. #	Address	City	Zip	Retrofitted (R) or New Construction (N)	General (G), PSN (P), Pet-Friendly (A)	Total Risk Capacity In People (Meets ARC 4496)	Total Risk Capacity (ft <sup>2</sup> ) (Meets ARC 4496)	Risk Capacity In People (Does not Meet ARC 4496 or Not Yet Surveyed)	Local Planned Usage (reported capacity)	Funding Source: Local (L), State (S), Federal (F), and Program Name	Comments
Fellsmere Elementary School	7	50 North Cypress Street	Fellsmere	32948	R	G	490	7,349	0	570	HMGP	Update Per FISH
Gifford Middle School	6	2726 45th Street	Vero Beach	32967	R	G	159	1,912	0	159	HMGP	Update Per FISH
Gifford Middle School	12	2726 45th Street	Vero Beach	32967	R	G	168	3,896	0	168	HMGP	Need ASCE7 cert??? New FISH
Gifford Middle School	7-Gym	2726 45th Street	Vero Beach	32967		G	0	0	585			11,711 sqft built 2005 per FISH, no surge
Glendale Elementary School	3	4940 8th Street	Vero Beach	32960		G	0	0	146			7,514 sqft built 1987 per FISH Remove?
Glendale Elementary School	4	4940 8th Street	Vero Beach	32960		G	0	0	44			5,524 sqft built 1987 per FISH Remove?
Highlands Elementary School	1	500 SW 20th Street	Vero Beach	32962		G	0	0	190			7,713 sqft built 1987 per FISH Remove?
Highlands Elementary School	2	500 SW 20th Street	Vero Beach	32962		G	0	0	415			6,198 sqft built 1987 per FISH Remove?
Highlands Elementary School	3	500 SW 20th Street	Vero Beach	32962		G	0	0	403			6,698 sqft built 1987 per FISH Remove?
J. A. Thompson Elementary School	MultiPur.	1110 18th Avenue SW	Vero Beach	32962	R	G	1,106	22,120			Per PBSJ report	18,819 sqft built 1982 per FISH Bldg.1
Treasure Coast ES (Old Liberty Magnall		6850 81st Street	Vero Beach	32962	R	G	0	0			L	changed to SpNS
Oslo Middle School	2	480 SW 20th Street	Vero Beach	32962	R	G	579	10,808	0	579		Update Per FISH
Oslo Middle School	5	480 SW 20th Street	Vero Beach	32962	R	G	149	2,230	0	158	HMGP	Update Per FISH
Oslo Middle School	6	480 SW 20th Street	Vero Beach	32962	R	G	250	6,240	0	243	HMGP	Update Per FISH
Oslo Middle School	7	480 SW 20th Street	Vero Beach	32962	R	G	579	10,718	0	579	HMGP	Update Per FISH
Oslo Middle School	900	480 SW 20th Street	Vero Beach	32962	R	G	580	10,699	0	580	HMGP	Update Per FISH
Oslo Middle School	8-Gym	480 SW 20th Street	Vero Beach	32962		G	0	0	0		HMGP	13,403 sqft built 1994 per FISH Remove?
Pelican Island Elementary School	1	1355 Schumann Drive	Sebastian	32958		G	0	0	131		HMGP	Campus total 26,057 sqft per FISH
Pelican Island Elementary School	1a	1355 Schumann Drive	Sebastian	32958		G	0	0	280			
Pelican Island Elementary School	1b	1355 Schumann Drive	Sebastian	32958		G	0	0	494			
Pelican Island Elementary School	Dining Area/Stage	1355 Schumann Drive	Sebastian	32958		G	0	0	102			
Pelican Island Elementary School	MultiPur.	1355 Schumann Drive	Sebastian	32958	R	G	61	999		61		
Pelican Island Elementary School	Music Room	1355 Schumann Drive	Sebastian	32958		G	0	0	31			
Sebastian Elementary School	900	400 Sebastian Boulevard	Sebastian	32958	R	G	313	4,690		371	HMGP	Update Per FISH
Sebastian River High School	A	9001 90th Avenue	Sebastian	32958	R	G	0	8,209	0		HMGP	Update Per FISH
Sebastian River High School	C	9001 90th Avenue	Sebastian	32958	R	G	0	2,077	0			Update Per FISH
Sebastian River High School	F	9001 90th Avenue	Sebastian	32958	R	G	0	6,124	0			Update Per FISH
Sebastian River High School	G	9001 90th Avenue	Sebastian	32958	R	G	0	4,040	0		HMGP	Update Per FISH
Sebastian River High School	Gym	9001 90th Avenue	Sebastian	32958		G	0	0	0			Update Per FISH
Sebastian River High School	J	9001 90th Avenue	Sebastian	32958	R	G	0	5,155	0			Update Per FISH
Sebastian River High School	K	9001 90th Avenue	Sebastian	32958	R	G	0	735	0		HMGP	Update Per FISH
Sebastian River High School	L	9001 90th Avenue	Sebastian	32958	R	G	0	2,665	0		HMGP	Update Per FISH
Sebastian River High School	M	9001 90th Avenue	Sebastian	32958	R	G	0	7,337	0		HMGP	Update Per FISH
Sebastian River High School	N	9001 90th Avenue	Sebastian	32958	R	G	0	6,932	0		HMGP	Update Per FISH
Sebastian River High School	V	9001 90th Avenue	Sebastian	32958	R	G	684	13,682	0		HMGP	Update Per FISH
Sebastian River Middle School	All	9400 CR 512	Sebastian	32968	R	G	1,499	53,520	0	1,499	HMGP	Update Per FISH
Sebastian River Middle School	Gym	9400 CR 512	Sebastian	32968		G	0	0	0		HMGP	
Sebastian Senior Center	Center	815 Davis Str	Sebastian	32958	R	G	140	2,800	0	140	HMGP	
Vero Beach High School		1707 16th Street	Vero Beach	32960		G	0	0	929		HMGP	Bldg. A dropped per county,
Vero Beach High School Freshman L	All	1507 19th Street	Vero Beach	32960	R	G	1,499	51,223	0	1,499	S-1543	Update Per FISH bldg.1 parcel 1
Vero Beach High School Freshman L	Gym	1507 19th Street	Vero Beach	32960		G	0	0	0			
<b>TOTALS FOR INDIAN RIVER COUNTY</b>							<b>8,256</b>	<b>246,160</b>	<b>3,750</b>	<b>6,606</b>		<b>0</b>
Year 2012	Shelter Capacity In People	Shelter Demand In People	Surplus/Deficit In People	Shelter Capacity (ft2)			Surplus/Deficit (ft2)	Result				
Storm Category 4/5	8,256	3,524	4,732	246,160			175,680					
<b>Special Needs Storm Shelters</b>												

**2012 Statewide Emergency Shelter Plan**

**INDIAN RIVER**

Name	Bldg #	Address	City	Zip			SpNS Capacity (spaces @ 60sf) (meets ARC 4496)	SpNS Capacity (sf) (meets ARC 4496)	SpNS Capacity (spaces @ 60sf) (does not meet ARC 4496)	Local Planned Usage (reported capacity)	Funding Source: Local (L), State (S), Federal (F), and Program Name	Comments
Treasure Coast ES (Old Liberty Magn	all	8955 85th Street	Sebastian	32958	R	P,A	582	34,920		582		per master list
								0				
Year 2012	SpNs Shelter Capacity In Spaces (meets ARC 4496)	SpNs Shelter Demand In Spaces	Surplus/ Deficit In Spaces	SpNs Shelter Capacity (ft2)			Surplus/ Deficit (ft2)	Result				
Storm Category 4/5	582	1,954	-1,372	34,920			-82,320					

2012 Statewide Emergency Shelter Plan

JACKSON

Name	Bldg. #	Address	City	Zip	Retrofitted (R) or New Construction (N)	General (G), PSN (P), Pet-Friendly (A)	Total Risk Capacity In People (Meets ARC 4496)	Total Risk Capacity (ft <sup>2</sup> ) (Meets ARC 4496)	Risk Capacity In People (Does not Meet ARC 4496 or Not Yet Surveyed)	Local Planned Usage (reported capacity)	Funding Source: Local (L), State (S), Federal (F), and Program Name	Comments
Cottondale High School		2680 Levy Street	Cottondale	32431			0	0				0
Graceville Civic Center		Highway 169	Graceville	32440			0	0				0
Graceville High School		5539 Brown Street, Hwy	Graceville	32440			0	0				0
Grand Ridge High School		6925 Florida Street	Grand Ridge	32442			0	0				0
Marianna High School		2979 Daniels Street	Marianna	32446			0	0				0
new Marianna High School	Area A	3546 Caverns RD	Marianna	32448	N	G	354	8,355		354		Updated FISH
new Marianna High School	Area B	3546 Caverns RD	Marianna	32448	N	G	1,356	20,338		1,429		partly SpNS (Total=22,318sf per FISH)
new Marianna High School	Area C	3546 Caverns RD	Marianna	32448	N	G	284	6,649		284		Updated FISH Data
new Marianna High School	Area D/D1	3546 Caverns RD	Marianna	32448	N	G	469	11,725		354		Updated FISH Data
new Marianna High School	Area E	3546 Caverns RD	Marianna	32448	N	G	253	4,770		253		Updated FISH Data
new Marianna High School	Area F/F1	3546 Caverns RD	Marianna	32448	N	G	616	15,391		228		Updated FISH Data
Sunland Center- Marianna	Residence Bldgs	3700 Williams Drive	Marianna	32446			0	0				host only- clients 360
Sunland Center- Marianna	Non-Residence Bldgs	3700 Williams Drive	Marianna	32446			0	0				host only- clients 395
Chipola Junior College	PSC		marianna	32448	R	G	499	9,980		499	F,S	capacity per ARMOR
Family Service Center	1				R	G	0	0			F,S	
Golson ES	East				R	G	0	0			F,S	
Golson ES	West				R	G	0	0			F,S	
Malone SHS	14		Malone		R	G	0	0				1588-2006-not done
Graceville HS	2		Graceville		R	G	0	0				1588-2006-not done
<b>TOTALS FOR JACKSON COUNTY</b>							<b>3,831</b>	<b>77,208</b>	<b>0</b>	<b>3,401</b>		<b>0</b>

Year 2012	Shelter Capacity In People	Shelter Demand In People	Surplus/ Deficit In People	Shelter Capacity (ft <sup>2</sup> )	Surplus/ Deficit (ft <sup>2</sup> )	Result
Storm Category 4/5	3,831	1,122	2,709	77,208	54,768	

Special Needs Storm Shelters

Name	Bldg #	Address	City	Zip	SpNS Capacity (spaces @ 60sf) (meets ARC 4496)	SpNs Capacity (sf) (meets ARC 4496)	SpNS Capacity (spaces @ 60sf) (does not meet ARC 4496)	Local Planned Usage (reported capacity)	Funding Source: Local (L), State (S), Federal (F), and Program Name	Comments
New Marianna Hs	Area B (part of area)	3546 Caverns RD	Marianna	32448		33	1,980	33		Updated FISH Data

Year 2012	SpNs Shelter Capacity In Spaces (meets ARC 4496)	SpNs Shelter Demand In Spaces	Surplus/ Deficit In Spaces	SpNs Shelter Capacity (ft <sup>2</sup> )	Surplus/ Deficit (ft <sup>2</sup> )	Result
Storm Category 4/5	33	95	-62	1,980	-3,720	

**2012 Statewide Emergency Shelter Plan**

**JEFFERSON**

Name	Bldg. #	Address	City	Zip	Retrofitted (R) or New Construction (N)	General (G), PSN (P), Pet-Friendly (A)	Total Risk Capacity In People (Meets ARC 4496)	Total Risk Capacity (ft <sup>2</sup> ) (Meets ARC 4496)	Risk Capacity In People (Does not Meet ARC 4496 or Not Yet Surveyed)	Local Planned Usage (reported capacity)	Funding Source: Local (L), State (S), Federal (F), and Program Name	Comments
First Baptist Church		325 West Washington St	Monticello	32344			0	0	100			0
First United Methodist Church		325 West Walnut Street	Monticello	32344			0	0	75			0
Jefferson County High School		555 Tiger Lane	Monticello	32344			0	0	300			0
Mormon Church		Spring Hollow Road	Monticello	32344			0	0	40			0
New Jefferson County Middle/Sr. High	Gym & Café (b8)	50 David Rd	Monticello	32344	N	G	809	15,231		809	L	Updated FISH Data
							0	0				
							0	0				
<b>TOTALS FOR JEFFERSON COUNTY</b>							<b>809</b>	<b>15,231</b>	<b>515</b>	<b>809</b>		<b>0</b>
Year 2012	Shelter Capacity In People	Shelter Demand In People	Surplus/ Deficit In People	Shelter Capacity (ft <sup>2</sup> )			Surplus/ Deficit (ft <sup>2</sup> )	Result				
Storm Category 4/5	809	283	526	15,231			9,571					
<b>Special Needs Storm Shelters</b>												
Name	Bldg #	Address	City	Zip			SpNS Capacity (spaces @ 60sf) (meets ARC 4496)	SpNs Capacity (sf) (meets ARC 4496)	SpNS Capacity (spaces @ 60sf) (does not meet ARC 4496)	Local Planned Usage (reported capacity)	Funding Source: Local (L), State (S), Federal (F), and Program Name	Comments
Uses Regional Shelter								0				
								0				
Year 2012	SpNs Shelter Capacity In Spaces (meets ARC 4496)	SpNs Shelter Demand In Spaces	Surplus/ Deficit In Spaces	SpNs Shelter Capacity (ft <sup>2</sup> )			Surplus/ Deficit (ft <sup>2</sup> )	Result				
Storm Category 4/5	0	137	-137	0			-8,220					

**2012 Statewide Emergency Shelter Plan**

**LAFAYETTE**

Name	Bldg. #	Address	City	Zip	Retrofitted (R) or New Construction (N)	General (G), PSN (P), Pet-Friendly (A)	Total Risk Capacity In People (Meets ARC 4496)	Total Risk Capacity (ft <sup>2</sup> ) (Meets ARC 4496)	Risk Capacity In People (Does not Meet ARC 4496 or Not Yet Surveyed)	Local Planned Usage (reported capacity)	Funding Source: Local (L), State (S), Federal (F), and Program Name	Comments
4th District Community Ctr- 16 miles East of Mayo		Hwy 27 South	Mayo	32066			0	0	0			
Airline Community Ctr - 5 miles East of Mayo		Hwy 27 South	Mayo	32066			0	0	0			
Day Community Center - North of Day		CR 53	Mayo	32066			0	0	0			
Lafayette High School Gym	32-gym	US 27 East	Mayo	32066	R	G	332	6,640			1621X	09-SR-18-03-4-01-210
Lafayette High School, Cafeteria	2-cafeteria	US 27 East	Mayo	32066	R	G	255	3,827		278	F	Updated FISH Data
Mayo Community Ctr - 1 mile West of Mayo		Hwy 27 North	Mayo	32066			0	0	0			
Oakridge Assisted Living		1343 Johns St	Mayo	32066	N	P	0	0		90	L	
<b>TOTALS FOR LAFAYETTE COUNTY</b>							<b>587</b>	<b>10,467</b>	<b>0</b>	<b>368</b>		
Year 2012	Shelter Capacity In People	Shelter Demand In People	Surplus/ Deficit In People	Shelter Capacity (ft <sup>2</sup> )			Surplus/ Deficit (ft <sup>2</sup> )	Result				
Storm Category 4/5	587	560	27	10,467			-733					
<b>Special Needs Storm Shelters</b>												
Name	Bldg #	Address	City	Zip			SpNS Capacity (spaces @ 60sf) (meets ARC 4496)	SpNs Capacity (sf) (meets ARC 4496)	SpNS Capacity (spaces @ 60sf) (does not meet ARC 4496)	Local Planned Usage (reported capacity)	Funding Source: Local (L), State (S), Federal (F), and Program Name	Comments
Oakridge Assisted Living		1343 Johns St	Mayo	32066	N	P	60	3,600		90	L	
Year 2012	SpNs Shelter Capacity In Spaces (meets ARC 4496)	SpNs Shelter Demand In Spaces	Surplus/ Deficit In Spaces	SpNs Shelter Capacity (ft <sup>2</sup> )			Surplus/ Deficit (ft <sup>2</sup> )	Result				
Storm Category 4/5	60	14	46	3,600			2,760					

2012 Statewide Emergency Shelter Plan

LAKE

Name	Bldg. #	Address	City	Zip	Retrofit ted (R) or New Constr uction (N)	General (G), PSN (P), Pet - Friendly (A)	Total Risk Capacity In People (Meets ARC 4496)	Total Risk Capacity (ft <sup>2</sup> ) (Meets ARC 4496)	Risk Capacity In People (Does not Meet ARC 4496 or Not Yet Surveyed)	Local Planned Usage (reported capacity)	Funding Source: Local (L), State (S), Federal (F), and Program Name	Comments
Astatula Elementary School for the Arts	1	13925 Florida Avenue	Astatula	34705	N	G/A	68	1,025		116	S-1523	Primary Shelter;Updated FISH
Astatula Elementary School for the Arts	2	13925 Florida Avenue	Astatula	34705	N	G/A	296	6,247		296	S-1523	Primary Shelter;Updated FISH
Astatula Elementary School for the Arts	3	13925 Florida Avenue	Astatula	34705	N	G/A	309	4,628		315	S-1523	Primary Shelter;Updated FISH
Beverly Shores Elementary School	14	1108 West Griffin Road	Leesburg	34745	N	G	167	4,170		80	L	Secondary Shelter;Updated FISH
Beverly Shores Elementary School	15	1108 West Griffin Road	Leesburg	34745	N	G	382	5,737		389	L	Secondary Shelter;Updated FISH
Beverly Shores Elementary School	16	1108 West Griffin Road	Leesburg	34745	N	G	235	4,251		235	L	Secondary Shelter;Updated FISH
Carver Middle School	2	1200 N. Beecher Street	Leesburg	34745	N	G	952	14,285		1,009	L	Secondary Shelter;Updated FISH
Carver Middle School	3	1200 N. Beecher Street	Leesburg	34745	N	G	504	7,713		504	L	Secondary Shelter;Updated FISH
Carver Middle School	4	1200 N. Beecher Street	Leesburg	34745	N	G	398	9,952		292	L	Secondary Shelter;Updated FISH
Carver Middle School	5	1200 North Beecher Street	Leesburg	34745	N	G	778	11,667		986	L	Secondary Shelter;Updated FISH
East Ridge High School	21	13322 Excalibur Road	Clermont	34711	N	G	846	12,690		929	L	Secondary Shelter;Updated FISH
East Ridge Middle	2	13201 Excalibur Road	Clermont	34711	N	G	1,016	20,320		1,016	L	Secondary Shelter;Updated FISH shows 32,193 sqft
Sorrento Elementary	1	24605 Wallick Road	Sorrento	32776	N	G	0	0	929	929	L-School Board	Secondary Shelter; Need survey 47,200 sqft
Eustis High School	3	1300 East Washinton Avenue	Eustis	32726	N	G	462	10,962		462	L	Secondary Shelter;Updated FISH
Eustis Middle School	5	18725 East Bates Avenue	Eustis	32726	N	G	793	19,821		632	L	Secondary Shelter;Updated FISH
Fruitland Park Elementary School	12	304 West Fountain Street	Fruitland Park	34731	N	G	272	5,038		272	L	Secondary Shelter;Updated FISH
Grassy Lake Elementary School	1	1100 Fosgate RD	Minneola	34714	N	G	2,675	53,306		2,675	L	Secondary Shelter;Updated FISH
Groveland Elementary School	1	930 Parkwood Avenue	Groveland	34736	N	G	613	13,089		613	L	Secondary Shelter;Updated FISH
Lake Minneola HS	1-admin/clas	101 N Hancock Road	Minneola	34715	N	G	0	0	1,009	1,009	L-School Board	Secondary Shelter;FISH shows 79,622 sqft
Lake Minneola HS	2-food	101 N Hancock Road	Minneola	34715	N	G	0	0	379	379	L-School Board	Secondary Shelter;FISH shows 5,368sqft
Lake Minneola HS	3-Auditor	101 N Hancock Road	Minneola	34715	N	G	0	0	117	117	L-School Board	Secondary Shelter;FISH shows 9,906 sqft
Lake Minneola HS	4-gym	101 N Hancock Road	Minneola	34715	N	G	0	0	775	775	L-School Board	Secondary Shelter;FISH shows 20,482 sqft
Leesburg Elementary School	1	2229 South Street	Leesburg	34748	N	G/A	0	0		41	L	Primary Shelter;Updated FISH
Leesburg Elementary School	3	2229 South Street	Leesburg	34748	N	P/A	0	0			L	Primary Shelter;FISH shows 6,389 sqft
Leesburg Elementary School	4	2229 South Street	Leesburg	34748	N	G/A	212	4,316		212	L	Primary Shelter;Updated FISH
Leesburg Elementary School	6	2229 South Street	Leesburg	34748	N	G/A	249	3,732		272	S-1523-State	Primary Shelter;Updated FISH
Leesburg High School	15	1401 West Meadows Avenue	Leesburg	34748	N	G	918	13,766		1,063	L	Secondary Shelter;Updated FISH
Lost Lake Elementary School	1	1901 Johns Lake Road	Clermont	34711	N	P/A	0	0			L	Primary Shelter;FISH shows 922 sqft
Lost Lake Elementary School	2	1901 Johns Lake Road	Clermont	34711	N	G/A	251	5,986		251	L	Primary Shelter;Updated FISH
Lost Lake Elementary School	3	1901 Johns Lake Road	Clermont	34711	N	G/A	303	4,590		303	L	Primary Shelter;Updated FISH
Mascotte Elementary Charter School	1	460 Midway Avenue	Mascotte	34753	N	G/A	929	18,580		929	L	Primary Shelter;Fish Shows 53,866 sqft
Minneola Elementary School	1	300 East Pearl Street	Minneola	34755	N	G	0	0	500	500	L	Secondary Shelter; Need survey 48,401 sqft
Mount Dora High School	5-media	700 North Highland Avenue	Mount Dora	32757	N	G	0	0	0	129	L	Secondary Shelter;Fish Shows 242 sqft Re
Mount Dora High School	7-café	700 North Highland Avenue	Mount Dora	32757	N	G	411	6,237		411	L	Secondary Shelter;Updated FISH
Mount Dora High School	8-audi	700 North Highland Street	Mount Dora	32757	N	G	414	7,897		414	L	Secondary Shelter;Updated FISH
Mount Dora High School	9-gym	700 North Highland Avenue	Mount Dora	32757	N	G	543	11,064		543	L	Secondary Shelter;Updated FISH
Pine Ridge Elementary	1-admn	10245 CR 561	Clermont	34711	N	G	83	1,640		83	L	Secondary Shelter;Fish Shows 840 sqft Re
Pine Ridge Elementary	3-Classrm	10245 CR 561	Clermont	34711	N	G	270	5,712		270	L	Secondary Shelter;Updated FISH
Pine Ridge Elementary	4-food	10245 CR 561	Clermont	34711	N	G	212	4,264		212	L	Secondary Shelter;Updated FISH
Pine Ridge Elementary	6-classrm	10245 CR 561	Clermont	34711	N	G	249	3,732		272	L	Secondary Shelter;Updated FISH
Round Lake Elementary School	1	31333 Round Lake Road	Mt. Dora	32757	N	G/A	83	1,641		83	L	Primary Shelter
Round Lake Elementary School	3	31333 Round Lake Road	Mt. Dora	32757	N	G/A	270	5,701		270	L	Primary Shelter;Updated FISH
Round Lake Elementary School	4	31333 Round Lake Road	Mt. Dora	32757	N	G/A	212	4,206		212	L	Primary Shelter;Updated FISH
Round Lake Elementary School	6	31333 Round Lake Road	Mt. Dora	32757	N	G/A	249	3,742		272	S-1523	Primary Shelter;Updated FISH
Sawgrass Bay Elementary School	1	16325 Superior Blvd	Clermont	34714	N	G	2,545	53,306		2,545	L	Secondary Shelter;Updated FISH
Seminole Springs Elementary School	1	26200 West Huff Road	Eustis	32726	R	G	140	2,623		140	S-1523	Secondary Shelter;Fish Shows 304 sqft Re
Seminole Springs Elementary School	4-food	26200 West Huff Road	Eustis	32726	R	G	198	3,433		198	S-1523	Secondary Shelter
South Lake High School	1	15600 Silver Lake Road	Groveland	34736	R	G	406	7,536		406	L	Secondary Shelter;Updated FISH
South Lake High School	2	15600 Silver Lake Road	Groveland	34736	R	G	466	6,990		503	L	Secondary Shelter;Updated FISH
South Lake High School	3	15600 Silver Lake Road	Groveland	34736	R	G	481	8,033		481	S-1523	Secondary Shelter;Updated FISH
South Lake High School	4	15600 Silver Lake Road	Groveland	34736	R	G	265	3,978		534	L	Secondary Shelter;Updated FISH
South Lake High School	5	15600 Silver Lake Road	Groveland	34736	R	G	100	2,190		100	L	Secondary Shelter;Updated FISH
South Lake High School	16	15600 Silver Lake Road	Groveland	34736	N	G	392	7,840		392	L	Secondary Shelter;Updated FISH
South Lake High School	17	15600 Silver Eagle Road	Groveland	34736	N	G	929	18,580		929	L	Secondary Shelter;Updated FISH
Spring Creek Elementary School	1	44440 Spring Creek Road	Paisley	32767	R	G	79	1,188		223	S-1523	Secondary Shelter;Fish Shows 141 sqft Re
Spring Creek Elementary School	4	44440 Spring Creek Road	Paisley	32767	R	G	173	3,346		173	S-1523	Secondary Shelter;Updated FISH

**2012 Statewide Emergency Shelter Plan**

**LAKE**

Name	Bldg. #	Address	City	Zip	Retrofit ted (R) or New Constr uction (N)	General (G), PSN (P), Pet - Friendly (A)	Total Risk Capacity In People (Meets ARC 4496)	Total Risk Capacity (ft <sup>2</sup> ) (Meets ARC 4496)	Risk Capacity In People (Does not Meet ARC 4496 or Not Yet Surveyed)	Local Planned Usage (reported capacity)	Funding Source: Local (L), State (S), Federal (F), and Program Name	Comments
Tavares High School	7-gym	603 New Hampshire Avenue	Tavares	32778	N	G	413	10,337		376	L	Secondary Shelter;Updated FISH
Tavares Middle School	5-classrm	13032 Lane Park Cutoff	Tavares	32778	N	G/A	632	15,616		632	L	Secondary Shelter;Updated FISH
Treadway Elementary School	11	10619 Treadway School Ro	Leesburg	34748	N	G/A	249	3,740		272	L	Primary Shelter;Updated FISH
Treadway Elementary School	12	10619 Treadway School Ro	Leesburg	34748	N	G/A	272	5,129		272	L	Primary Shelter;Updated FISH
Treadway Elementary School	13-food	10619 Treadway School Ro	Leesburg	34748	N	G/A	212	4,227		212	L	Primary Shelter;Updated FISH
Umatilla Elementary School	1	60 Smith Street	Umatilla	32784	N	G/A	64	966		83	L	Primary Shelter;Updated FISH
Umatilla Elementary School	3	60 Smith Street	Umatilla	32784	N	P/A	0	0	0		L	SpNS
Umatilla Elementary School	4	60 Smith Street	Umatilla	32784	N	G/A	227	4,146		227	L	Primary Shelter;Updated FISH
Umatilla Elementary School	6	60 Smith Street	Umatilla	32784	N	G/A	249	3,732		272	L	Primary Shelter;Updated FISH
Umatilla High School	28	320 North Trowell Avenue	Umatilla	32784	N	G,A	382	9,558		379	L	Secondary Shelter;Updated FISH
Villages Elementary School	1	695 Rolling Acres Road	Lady Lake	32159	N	P	0	0			S-1523	SpNS
Villages Elementary School	2	695 Rolling Acres Road	Lady Lake	32159	N	G	296	6,176		296	S-1523	Primary Shelter;Updated FISH
Villages Elementary School	3	695 Rolling Acres Road	Lady Lake	32159	N	G	309	4,629		315	S-1523	Primary Shelter;Updated FISH
<b>TOTALS FOR LAKE COUNTY</b>							<b>26,103</b>	<b>499,006</b>	<b>3,709</b>	<b>30,732</b>		<b>0</b>
Year 2012	Shelter Capacity In People	Shelter Demand In People	Surplus/ Deficit In People	Shelter Capacity (ft2)			Surplus/ Deficit (ft2)	Result				
Storm Category 4/5	26,103	25,231	872	499,006			-5,614					
<b>Special Needs Storm Shelters</b>												
Name	Bldg #	Address	City	Zip			SpNS Capacity (spaces @ 60sf) (meets ARC 4496)	SpNs Capacity (sf) (meets ARC 4496)	SpNS Capacity (spaces @ 60sf) (does not meet	Local Planned Usage (reported capacity)	Funding Source: Local (L), State (S), Federal (F), and Program	Comments
Leesburg ES	3	2229 South Street	Leesburg	34748	N	P/A	135	6,389		135		Primary Shelter;updated FISH
Lost Lake ES	1	1901 Johns Lake Road	Clemont	34711	N	P/A	23	922		51	L-School Board	Primary Shelter;updated FISH
Umatilla ES	3	320 North Trowell Avenue	Umatilla	32784	N	P/A	135	5,697		135		Primary Shelter;updated FISH
Villages ES	1	695 Rolling Acres Road	Lady Lake	32159	N	P	21	842		51		Backup SpNS Shelter;updated FISH
Year 2012	SpNs Shelter Capacity In Spaces (meets	SpNs Shelter Demand In Spaces	Surplus/ Deficit In Spaces	SpNs Shelter Capacity (ft2)			Surplus/ Deficit (ft2)	Result				
Storm Category 4/5	314	384	-70	18,840			-4,200					



2012 Statewide Emergency Shelter Plan

LEE

Name	Bldg. #	Address	City	Zip	Retrofitted (R) or New Construction (N)	General (G), PSN (P), Pet-Friendly (A)	Total Risk Capacity In People (Meets ARC 4496)	Total Risk Capacity (ft <sup>2</sup> ) (Meets ARC 4496)	Risk Capacity In People (Does not Meet ARC 4496 or Not Yet Surveyed)	Local Planned Usage (reported capacity)	Funding Source: Local (L), State (S), Federal (F), and Program Name	Comments
Alico Arena (Florida Gulf Coast Univ/)	GYM	ben c griffin parkway	Estero	33928	N	G	0	0		1,685	L	existing storm shelter, 5.6' SLOSH
Alva ES/MS		21290 Park Street	Alva	33920		G	0	0	283	283	L	
Colonial Elementary School	4,6,7,9,12	3800 Schoolhouse Rd East	Ft. Myers	33916	R	G	0	0		1,545	L	existing storm shelter;updated FISH, 9' SLOSH
Diplomat Elementary School	4,6,7,8,9	1115 NE 16th Terrace	Cape Coral	33990	R	G	0	0		1,600	L	existing storm shelter;updated FISH, 11.3' SLOSH
Diplomat Middle School	cafeteria	1039 NE 16th Terrace	Cape Coral	33990	R	G	0	0	1,000	1,000		existing storm shelter-PBSJ report no window protection? Bldg.#3= 7,145 sqft, 10.3' SLOSH
Dunbar High	19,20 (gym)	3800 E. Edison Avenue	Ft. Myers	33903	N	G	0	0		800	L	existing storm shelter, 7.7' SLOSH
East lee HS	part of site	715 Thomas Sherwin	Lehigh	33971	N	G	0	0		2,000	L	open 8/07-, 5.4' SLOSH
Estero Community Center	entire site	Corkscrew Palm Road	EStero	33928	N	G	0	0		2,500	L	NEW LATE 2006, 11' SLOSH
Estero High School	Gym	21900 River Ranch Road	Estero	33928		G	0	0				HOST ONLY, 9.7' SLOSH
Germain Arena	Arena 1	11000 Everglades Parkway	Estero	33928	R	G	0	0		6,500	L	existing storm shelter, 9.2' SLOSH
Harns Marsh ES	entire site	15511 Homestaed RD	Lehigh	33971	N	G	0	0		1,200	L	New School 06 Construction EHPA, 7' SLOSH
Heights Elementary School	cafeteria	15200 Alexandria COurt	Ft. Myers	33908		G	0	0	1,000		20.2' SLOSH	existing storm shelter
Islands Coast HS	entire site	2125 DeNavarra Parkway	Cape Coral	33991	N	G	0	0		3,000	L	8/08 construction EHPA-exiting storm, 10.1' SLOSH
J. Colin English ES	2story bldg	120 Pine Island Rd	N. Ft. Myers	33903	R	G	0	0		800	L	existing storm shelter, 12.5' SLOSH
Lee County Civic Center	Civic Center	11831 Bayshore Road	North Ft. Myers	33917		G	0	0	5,000		21.2' SLOSH	HOST ONLY
Lee Middle School	2,3,6,7,8,9	1333 Marsh Avenue	Ft. Myers	33905	R	G	0	0		620	L	existing storm shelter, 10.6' SLOSH
Lehigh Senior High School	Center bldg square	801 Gunnery Road North	Lehigh Acres	33971	R	G	0	0	0	380	L	2.8' SLOSH
Littleton Elementary School	1,4,5,6,8 (Corridors)	700 Hutto Road	North Ft. Myers	33903		G	0	0		1,425	L	existing storm shelter, 11.7' SLOSH
Mariner High School	Auditorium	701 Chiquita Boulevard	Cape Coral	33909		G	0	0	345			existing storm shelter- open span, 13' SLOSH
Mariner Middle School	Entire school	425 Chiquita Blvd	Cape Coral	3909	N	G	0	0		800		new school, 13.1' SLOSH
Mirror Lakes Elementary School	Corridors	525 Charwood Avenue	Lehigh	33936	N	G	0	0	0	1,000		existing storm shelter, 4.7' SLOSH
North Ft. Myers Academy of Arts	Entire School	1856 Arts Way	N. Ft. Myers	33907	R	G	0	0	3,563	2,500	L	existing storm shelter-roof questions per report, 10.6'
Oak Hammock	Entire Site	5321 Tice Street	Ft Myers	33905		N G	0	0		1,200	L	8/08 construction EHPA-exiting stom?, 8.5' SLOSH
Riverdale High School	Gym & Cafeteria	2600 Buckingham Road	Ft. Myers	33905		G	0	0		1,150		HOST ONLY, 14.8' SLOSH
Skyline Elementary School	Screened	620 SW 19th Street	Cape Coral	33991	R	G	0	0	1,695			existing storm shelter, 13.7' SLOSH
South Ft. Myers HS - **Check Surge!	Entire	14021 Plantation Blvd	Ft. Myers	33916	N	G/A	0	0				new school
Tanglewood Elementary School	Corridors	1620 Manchester Blvd	Ft. Myers	33919	R	G	0	0	800			existing storm shelter, 16.6' SLOSH
Three Oaks Elementary School	Classrooms & Cafeteria	19600 Three Oaks Parkway	San Carlos Park	33912		G	0	0	1,715			existing storm shelter, 9.2' SLOSH
Three Oaks Middle School	Classrooms & Cafeteria	18500 Three Oaks Parkway	San Carlos Park	33912		G	0	0	1,440			existing storm shelter, 8.5' SLOSH
Tice Elementary School		4524 Tice Street	Ft. Myers	33905		G	0	0	100			existing storm shelter, 11.7' SLOSH
Varsity Lakes MS	1	801 North Gunnery Rd	Lehigh Acres	33971	N	G	0	0		1,000	L	2005 consturction HVVWZ-exiting storm, 3.4' SLOSH
Varsity Lakes MS	2	801 North Gunnery Rd	Lehigh Acres	33971	N	G	0	0			L	2005 consturction HVVWZ-exiting storm, 3.4' SLOSH
Varsity Lakes MS	3	801 North Gunnery Rd	Lehigh Acres	33971	N	G	0	0			L	2005 consturction HVVWZ-exiting storm, 3.4' SLOSH
Varsity Lakes MS	4	801 North Gunnery Rd	Lehigh Acres	33971	N	G	0	0			L	2005 consturction HVVWZ-exiting storm, 3.4' SLOSH
Veterens Park ES/MS	Gym & entire School	55 Homestead Road	Lehigh Acres	33936	N	G	0	0		2,500		new school
YMCA	Entire site	E. Terry Avenue	Bonita Springs	33913	N	G	0	0		300		new bldg
<b>TOTALS FOR LEE COUNTY</b>							<b>0</b>	<b>0</b>	<b>16,941</b>	<b>35,788</b>		<b>0</b>

Year 2012	Shelter Capacity In People	Shelter Demand In People	Surplus/ Deficit In People	Shelter Capacity (ft2)	Surplus/ Deficit (ft2)	Result
Storm Category 4/5	0	32,216	-32,216	0	-644,320	

Special Needs Storm Shelters

Name	Bldg #	Address	City	Zip	SpNS Capacity (spaces @ 60sf) (meets ARC 4496)	SpNs Capacity (sf) (meets ARC 4496)	SpNS Capacity (spaces @ 60sf) (does not meet ARC 4496 or not yet surveyed)	Local Planned Usage (reported capacity)	Funding Source: Local (L), State (S), Federal (F), and Program Name	Comments
------	--------	---------	------	-----	--	-------------------------------------	--	---	---	----------

**2012 Statewide Emergency Shelter Plan**

LEE												
East Lee HiS	Part of site	715 Thomas Sherwin	Lehigh	33971	N	P	0	0		500	L	EHPA,5.4' SLOSH
Ray Potorff Elementary School	Entire Site	4600 Challenger Blvd	Ft. Myers	33912	N	P	0	0		0	S	06 EHPA & capacity. Built to 150 mph winds, in cat 4/5 evac zone. Exiting storm only, 5.2' SLOSH
<b>Year 2012</b>	<b>SpNs Shelter Capacity In Spaces (meets ARC 4496)</b>	<b>SpNs Shelter Demand In Spaces</b>	<b>Surplus/ Deficit In Spaces</b>	<b>SpNs Shelter Capacity (ft2)</b>			<b>Surplus/ Deficit (ft2)</b>	<b>Result</b>				
Storm Category 4/5	0	2,379	-2,379	0			-142,740					

**2012 Statewide Emergency Shelter Plan  
Exiting Storm**

LEE												
Name	Bldg. #	Address	City	Zip	Retrofitted (R) or New Construction (N)	General (G), PSN (P), Pet-Friendly (A)	Total Risk Capacity In People (Meets ARC 4496)	Total Risk Capacity (ft <sup>2</sup> ) (Meets ARC 4496)	Risk Capacity In People (Does not Meet ARC 4496 or Not Yet Surveyed)	Local Planned Usage (reported capacity)	Funding Source: Local (L), State (S), Federal (F), and Program Name	Comments
Alico Arena (Florida Gulf Coast Univ/	GYM	ben c griffin parkway	Estero	33928	N	G	1,685	36,500		1,685	L	exiting storm shelter, 5.6' SLOSH
Alva ES/MS		21290 Park Street	Alva	33920		G	0	0	283	283	L	
Colonial Elementary School	4,6,7,9,12	3800 Schoolhouse Rd East	Ft. Myers	33916	R	G	1,393	20898.15		1,545	L	exiting storm shelter;updated FISH, 9' SLOSH
Diplomat Elementary School	4,6,7,8,9	1115 NE 16th Terrace	Cape Coral	33990	R	G	1,410	21153.15		1,600	L	exiting storm shelter;updated FISH, 11.3' SLOSH
Diplomat Middle School	cafeteria	1039 NE 16th Terrace	Cape Coral	33990	R	G	0	0	1,000	1,000		exiting storm shelter-PBSJ report no window protection? Bldg.#3= 7,145 sqft, 10.3' SLOSH
Dunbar High	19,20 (gym)	3800 E. Edison Avenue	Ft. Myers	33903	N	G	800	16,000		800	L	exiting storm shelter, 7.7' SLOSH
East lee HS	part of site	715 Thomas Sherwin	Lehigh	33971	N	G	2,000	40,000		2,000	L	open 8/07-, 5.4' SLOSH
Estero Community Center	entire site	Corkscrew Palm Road	Estero	33928	N	G	2,500	50,000		2,500	L	NEW LATE 2006, 11' SLOSH
Estero High School	Gym	21900 River Ranch Road	Estero	33928		G	0	0				HOST ONLY, 9.7' SLOSH
Germain Arena	Arena 1	11000 Everglades Parkway	Estero	33928	R	G	6,500	135,000		6,500	L	exiting storm shelter, 9.2' SLOSH
Harns Marsh ES	entire site	15511 Homestaed RD	Lehigh	33971	N	G	1,200	24,000		1,200	L	New School 06 Construction EHPA, 7' SLOSH
Heights Elementary School	cafeteria	15200 Alexandria COurt	Ft. Myers	33908		G	0	0	1,000		20.2' SLOSH	exiting storm shelter
Islands Coast HS	entire site	2125 DeNavarra Parkway	Cape Coral	33991	N	G	3,000	60,000		3,000	L	8/08 construction EHPA-exiting storm, 10.1' SLOSH
J. Colin English ES	2story bldg	120 Pine Island Rd	N. Ft. Myers	33903	R	G	800	16,000		800	L	exiting storm shelter, 12.5' SLOSH
Lee County Civic Center	Civic Center	11831 Bayshore Road	North Ft. Myers	33917		G	0	0	5,000		21.2' SLOSH	HOST ONLY
Lee Middle School	2,3,6,7,8,9	1333 Marsh Avenue	Ft. Myers	33905	R	G	620	12,400		620	L	exiting storm shelter, 10.6' SLOSH
Lehigh Senior High School	Center bldg square	801 Gunnery Road North	Lehigh Acres	33971	R	G	380	32,172	0	380	L	2.8' SLOSH
Littleton Elementary School	1,4,5,6,8 (Corridors)	700 Hutto Road	North Ft. Myers	33903		G	1,425	28,500		1,425	L	exiting storm shelter, 11.7' SLOSH
Mariner High School	Auditorium	701 Chiquita Boulevard	Cape Coral	33909			0	0	345			exiting storm shelter- open span, 13' SLOSH
Mariner Middle School	Entire school	425 Chiquita Blvd	Cape Coral	33909	N	G	800	16,000		800		new school, 13.1' SLOSH
Mirror Lakes Elementary School	Corridors	525 Charwood Avenue	Lehigh	33936	N	G	1,000	20,000	0	1,000		exiting storm shelter, 4.7' SLOSH
North Ft. Myers Academy of Arts	Entire School	1856 Arts Way	N. Ft. Myers	33907	R	G	0	0	3,563	2,500	L	exiting storm shelter-roof questions per report, 10.6' SLOSH
Oak Hammock	Entire Site	5321 Tice Street	Ft Myers	33905	N	G	1,200	24,000		1,200	L	8/08 construction EHPA-exiting storm?, 8.5' SLOSH
Riverdale High School	Gym & Cafeteria	2600 Buckingham Road	Ft. Myers	33905		G	0	0		1,150		HOST ONLY, 14.8' SLOSH
Skyline Elementary School	Screened and	620 SW 19th Street	Cape Coral	33991	R	G	0	0	1,695			exiting storm shelter, 13.7' SLOSH
South Ft. Myers HS - **Check Surge	Entire	14021 Plantation Blvd	Ft. Myers	33916	N	G/A	3,000	60,000			new school	exiting storm shelter, 11.1' SLOSH
Tanglewood Elementary School	Corridors	1620 Manchester Blvd	Ft. Myers	33919	R	G	0	0	800			exiting storm shelter, 16.6' SLOSH
Three Oaks Elementary School	Classrooms & Cafeteria	19600 Three Oaks Parkway	San Carlos Park	33912		G	0	0	1,715			exiting storm shelter, 9.2' SLOSH
Three Oaks Middle School	Classrooms & Cafeteria	18500 Three Oaks Parkway	San Carlos Park	33912		G	0	0	1,440			exiting storm shelter, 8.5' SLOSH
Tice Elementary School		4524 Tice Street	Ft. Myers	33905		G	0	0	100			exiting storm shelter, 11.7' SLOSH
Varsity Lakes MS	1	801 North Gunnery Rd	Lehigh Acres	33971	N	G	192	3,838		1,000	L	2005 consturction HVWZ-exiting storm, 2.7' SLOSH
Varsity Lakes MS	2	801 North Gunnery Rd	Lehigh Acres	33971	N	G	509	10,172			L	2006 consturction HVWZ-exiting storm, 2.7' SLOSH
Varsity Lakes MS	3	801 North Gunnery Rd	Lehigh Acres	33971	N	G	1,416	28,311			L	2007 consturction HVWZ-exiting storm, 2.7' SLOSH
Varsity Lakes MS	4	801 North Gunnery Rd	Lehigh Acres	33971	N	G	450	9,007			L	2008 consturction HVWZ-exiting storm, 2.7' SLOSH
Veterans Park ES/MS	Gym & entire School	55 Homestead Road	Lehigh Acres	33936	N	G	2,500	50,000		2,500	new school	2005 consturction EHPA, 9' SLOSH
YMCA	Entire site	E. Terry Avenue	Bonita Springs	33913	N	G	300	6,000		300	new bldg	2006 Construction EHPA exiting storm shelter
<b>TOTALS FOR LEE COUNTY</b>							<b>35,080</b>	<b>719,951</b>	<b>16,941</b>	<b>35,788</b>		<b>0</b>
<b>Year 2012</b>	<b>Shelter Capacity In</b>	<b>Shelter Demand In People</b>	<b>Surplus/ Deficit In People</b>	<b>Shelter Capacity</b>			<b>Surplus/ Deficit (ft2)</b>					<b>Result</b>
Storm Category 4/5	35,080	32,216	2,864	719,951			75,631					
<b>Special Needs Storm Shelters</b>												
Name	Bldg #	Address	City	Zip			SpNS Capacity (spaces @ 60sf) (meets ARC 4496)	SpNs Capacity (sf) (meets ARC 4496)	SpNS Capacity (spaces @ 60sf) (does not meet ARC 4496 or not yet surveyed)	Local Planned Usage (reported capacity)	Funding Source: Local (L), State (S), Federal (F), and Program Name	Comments
East Lee HIS	Part of site	715 Thomas Sherwin	Lehigh	33971	N	P	500	30,000		500	L	EHPA

**2012 Statewide Emergency Shelter Plan  
Exiting Storm**

LEE												
Ray Potorff Elementary School	Entire Site	4600 Challenger Blvd	Ft. Myers	33912	N	P	1,200	72,000		1,200	S	06 EHPA & capacity. Built to 150 mph winds, in cat 4/5 evac zone. Exiting storm only, 5.2' SLOSH
Year 2012	SpNs Shelter Capacity In Spaces (meets ARC 4496)	SpNs Shelter Demand In Spaces	Surplus/ Deficit In Spaces	SpNs Shelter Capacity (ft2)			Surplus/ Deficit (ft2)	Result				
Storm Category 4/5	1,700	2,379	-679	102,000			-40,740					

**2012 Statewide Emergency Shelter Plan**

**LEON**

Name	Bldg. #	Address	City	Zip	Retrofitted (R) or New Construction (N)	General (G), PSN (P), Pet - Friend (A)	Total Risk Capacity In People (Meets ARC 4496)	Total Risk Capacity (ft <sup>2</sup> ) (Meets ARC 4496)	Risk Capacity In People (Does not Meet ARC 4496 or Not Yet Surveyed)	Local Planned Usage (reported capacity)	Funding Source: Local (L), State (S), Federal (F), and Program Name	Comments
Apalachee Elementary School		650 Trojan Trail	Tallahassee	32311		G	0	0				
Astoria Park Elementary School		2465 Atlas Road	Tallahassee	32303		G	0	0				
Belle Vue Middle School		2214 Belle Vue Way	Tallahassee	32303		G	0	0				
Bethel AME Church		501 West Orange Avenue	Tallahassee	32312		G	0	0				
Bond Elementary School		2204 Saxon Street	Tallahassee	32310		G	0	0				
Bucklake Elementary School	1	1600 Pedrick Road	Tallahassee	32311	R	G	408	6,123		521	HMGP	
Bucklake Elementary School	2	1600 Pedrick Road	Tallahassee	32311	R	G	298	4,469		400	HMGP	
Bucklake Elementary School	5	1600 Pedrick Road	Tallahassee	32311	R	G	253	3,795		275	HMGP	
Bucklake Elementary School	6	1600 Pedrick Road	Tallahassee	32311	R	G	321	4,772		321	HMGP	
Bucklake Elementary School	7	1600 Pedrick Road	Tallahassee	32311	R	G	110	1,651		140	HMGP	
Bucklake Elementary School	3 & 4	1600 Pedrick Road	Tallahassee	32311	R	G	76	1,145		217	HMGP	
Canopy Oaks Elementary School	1	3250 Point View Drive	Tallahassee	32303	R	G	203	4,060		203	HMGP	
Canopy Oaks Elementary School	2	3250 Point View Drive	Tallahassee	32303	R	G	381	5,710		440	HMGP	
Canopy Oaks Elementary School	3	3250 Point View Drive	Tallahassee	32303	R	G	427	6,400		544	HMGP	
Canopy Oaks Elementary School	4	3250 Point View Drive	Tallahassee	32303	R	G	388	5,827		410	HMGP	
Canopy Oaks Elementary School	5	3250 Point View Drive	Tallahassee	32303	R	G	479	7,040		479	HMGP	
Canopy Oaks Elementary School	6	3250 Point View Drive	Tallahassee	32303	R	G	221	3,310		281	HMGP	
Carolyn Brevard Elementary School	10	2006 Jackson Bluff Road	Tallahassee	32304	R	G	57	853		73	HMGP	
Carolyn Brevard Elementary School	11	2006 Jackson Bluff Road	Tallahassee	32304	R	G	125	1,872		158	HMGP	
Carolyn Brevard Elementary School	12	2006 Jackson Bluff Road	Tallahassee	32304	R	G	113	1,675		113	HMGP	
Carolyn Brevard Elementary School	13	2006 Jackson Bluff Road	Tallahassee	32304	R	G	124	1,860		158	HMGP	
Carolyn Brevard Elementary School	14	2006 Jackson Bluff Road	Tallahassee	32304	R	G	46	690		58	HMGP	
Chaires Elementary School	1	4774 Chaires Crossroads	Tallahassee	32311	R	G	228	5,694		112	HMGP	
Chaires Elementary School	2	4774 Chaires Crossroads	Tallahassee	32311	R	G	253	3,796		323	HMGP	
Chaires Elementary School	5	4774 Chaires Crossroads	Tallahassee	32311	R	G	127	1,901		277	HMGP	
Chaires Elementary School	6	4774 Chaires Crossroads	Tallahassee	32311	R	G	323	4,935		323	HMGP	
Chaires Elementary School	7	4774 Chaires Crossroads	Tallahassee	32311	R	G	174	2,604		221	HMGP	
Chaires Elementary School	3&4	4774 Chaires Crossroads	Tallahassee	32311	R	G	128	1,914		166	HMGP	
Conley Elementary School	1	2400 East Orange Avenue	Tallahassee	32301	N	G	67	1,332			EHPA per plans	
Conley Elementary School	2	2400 East Orange Avenue	Tallahassee	32301	N	G	276	5,527			EHPA per plans	
Cobb Middle School		915 Hillcrest Avenue	Tallahassee	32308		G	0	0	400			
Dearlake Middle School	2	9902 Deerlake Drive West	Tallahassee	32312	R	G	472	7,343		472	HMGP	
Dearlake Middle School	3	9902 Deerlake Drive West	Tallahassee	32312	R	G	472	7,449		472	HMGP	
Dearlake Middle School	4	9902 Deerlake Drive West	Tallahassee	32312	R	G	479	7,360		472	HMGP	
Dearlake Middle School	5	9902 Deerlake Drive West	Tallahassee	32312	R	G	78	1,167		154	HMGP	
Dearlake Middle School	7	9902 Deerlake Drive West	Tallahassee	32312	R	G	150	2,906		150	HMGP	
Desoto Trail Elementary School	1	2930 Velda Dairy Road	Tallahassee	32308	R	G	408	6,123		521	HMGP	
Desoto Trail Elementary School	2	2930 Velda Dairy Road	Tallahassee	32308	R	G	314	4,706		400	HMGP	
Desoto Trail Elementary School	4	2930 Velda Dairy Road	Tallahassee	32308	R	G	106	1,597		179	HMGP	
Desoto Trail Elementary School	5	2930 Velda Dairy Road	Tallahassee	32308	R	G	253	3,795		275	HMGP	
Desoto Trail Elementary School	6	2930 Velda Dairy Road	Tallahassee	32308	R	G	321	4,772		321	HMGP	
Desoto Trail Elementary School	7	2930 Velda Dairy Road	Tallahassee	32308	R	G	110	1,651		140	HMGP	
Everheart School		2750 Mission Road	Tallahassee	32303		G	0	0	100			
Fairview Middle School		3415 Zillah Street	Tallahassee	32311		G	0	0	400			
Faith Presbyterian Church		2200 North Meridian Road	Tallahassee	32303		G	0	0	120			
FAMU 77 Engineering Bldg	77/ 1st floor				N	G	517	10,341				
First Baptist Church		SR 363	Woodville	32362		G	0	0	100			
First Church of the Nazarene		1983 Mahan Drive	Tallahassee	32308		G	0	0	100			
Forest Heights Baptist Church		1200 West Sharpe Street	Tallahassee	32303		G	0	0	125			
Fort Braden Elementary School	1	15100 Blountstown Hwy	Tallahassee	32310	R	G	835	12,523		993	HMGP	

**2012 Statewide Emergency Shelter Plan**

**LEON**

Fort Braden Elementary School	2	15100 Blountstown Hwy	Tallahassee	32310	R	G	394	6,290	394	HMGP	
Fort Braden Elementary School	3	15100 Blountstown Hwy	Tallahassee	32310	R	G	301	4,508	363	HMGP	
Fort Braden Elementary School	4	15100 Blountstown Hwy	Tallahassee	32310	R	G	151	2,268	193	HMGP	
FSU School	1	3000 School House Rd	Tallahassee	32304	R	G	233	4,660	233	HMGP	
FSU School	3	3000 School House Rd	Tallahassee	32304	R	G	0	0		HMGP	
FSU School	4	3000 School House Rd	Tallahassee	32304	R	G	0	0	733	HMGP	
FSU School	5	3000 School House Rd	Tallahassee	32304	R	G	367	7,340	367	HMGP	
FSU School	6	3000 School House Rd	Tallahassee	32304	R	G	411	8,220	411	HMGP	
FSU School	8	3000 School House Rd	Tallahassee	32304	R	G	0	0	643	HMGP	
FSU School	9	3000 School House Rd	Tallahassee	32304	R	G	452	9,040	452	HMGP	
Gilchrist Elementary School		695 Timberlane Road	Tallahassee	32312		G	0	0			
Godby High School		1717 West tharpe Street	Tallahassee	32303		G	0	0			
Griffin Middle School		800 Alabama Street	Tallahassee	32304		G	0	0			
Hartsfield Elementary School	9	1414 Chowkeebin Nene	Tallahassee	32301	R	G	78	1,176	100	HMGP	
Hartsfield Elementary School	10	1414 Chowkeebin Nene	Tallahassee	32301	R	G	69	1,036	88	HMGP	
Hartsfield Elementary School	11	1414 Chowkeebin Nene	Tallahassee	32301	R	G	47	706	136	HMGP	
Hartsfield Elementary School	12	1414 Chowkeebin Nene	Tallahassee	32301	R	G	141	2,108	179	HMGP	
Hartsfield Elementary School	16	1414 Chowkeebin Nene	Tallahassee	32301	R	G	93	1,395	112	HMGP	
Hawks Rise ES	1	205 Meadow Ridge Dr	Tallahassee	32301	R	G	131	2,640	131	HMGP	
Hawks Rise ES	2	205 Meadow Ridge Dr	Tallahassee	32301	R	G	384	5,755	404	HMGP	
Hawks Rise ES	3	205 Meadow Ridge Dr	Tallahassee	32301	R	G	238	3,564	303	HMGP	
Hawks Rise ES	4	205 Meadow Ridge Dr	Tallahassee	32301	R	G	182	2,727	249	HMGP	
Hawks Rise ES	5	205 Meadow Ridge Dr	Tallahassee	32301	R	G	453	6,802	553	HMGP	
Hawks Rise ES	6	205 Meadow Ridge Dr	Tallahassee	32301	R	G	348	5,224	444	HMGP	
Lawton Chiles High School	1	7200 Thomasville Road	Tallahassee	32312	R	G,A	295	5,900	295	HMGP	
Lawton Chiles High School	2	7200 Thomasville Road	Tallahassee	32312	R	G	789	12,591	792	HMGP	
Lawton Chiles High School	7	7200 Thomasville Road	Tallahassee	32312	R	G	1,775	28,379	1,478	HMGP	
Lawton Chiles High School	8	7200 Thomasville Road	Tallahassee	32312	R	G	1,061	17,508	958	HMGP	
Montford Middle School	2	5789 Pimlico Drive	Tallahassee	32309	N	G	385	7,693		EHPA per plans	
Oak Ridge Elem	2	4350 Shelfer Road	Tallahassee	32310	R	G	259	3,889	338	HMGP	
Oak Ridge Elem	6	4350 Shelfer Road	Tallahassee	32310	R	G	254	3,815	292	HMGP	
Pineview Elementary School		2230 Lake Bradford Road	Tallahassee	32310	R	G	0	0			
Raa Middle School		410 West Tharpe Street	Tallahassee	32303	R	G	0	0			
Rickards High School		3013 Jim Lee Road	Tallahassee	32301	R	G	0	0			
Riley Elementary School		1400 Indiana Street	Tallahassee	32304	R	G	0	0			
Roberts ES	1	5777 Centerville Rd	Tallahassee	32309	R	G	521	9,189	521	HMGP	
Roberts ES	2	5777 Centerville Rd	Tallahassee	32309	R	G	608	9,124	674	HMGP	
Roberts ES	3	5777 Centerville Rd	Tallahassee	32309	R	G	291	4,376	291	HMGP	
Roberts ES	4	5777 Centerville Rd	Tallahassee	32309	R	G	295	4,428	553	HMGP	
Springwood Elementary School	1	3801 Fred George Road	Tallahassee	32303	R	G	380	5,694	484	HMGP	
Springwood Elementary School	2	3801 Fred George Road	Tallahassee	32303	R	G	265	3,976	322	HMGP	
Springwood Elementary School	5	3801 Fred George Road	Tallahassee	32303	R	G	134	2,016	277	HMGP	
Springwood Elementary School	6	3801 Fred George Road	Tallahassee	32303	R	G	322	4,792	322	HMGP	
Springwood Elementary School	7	3801 Fred George Road	Tallahassee	32303	R	G	170	2,554	221	HMGP	
							0	0			
<b>TOTALS FOR LEON COUNTY</b>							<b>22,398</b>	<b>362,071</b>	<b>1,345</b>	<b>25,068</b>	<b>0</b>

Year 2012	Shelter Capacity In People	Shelter Demand In People	Surplus/ Deficit In People	Shelter Capacity (ft2)		Surplus/ Deficit (ft2)	Result			
Storm Category 4/5	22,398	2,713	19,685	362,071		307,811				

**Special Needs Storm Shelters**

**2012 Statewide Emergency Shelter Plan**

**LEON**

Name	Bldg #	Address	City	Zip			SpNS Capacity (spaces @ 60sf) (meets ARC 4496)	SpNs Capacity (sf) (meets ARC 4496)	SpNS Capacity (spaces @ 60sf) (does not meet ARC 4496)	Local Planned Usage (reported capacity)	Funding Source: Local (L), State (S), Federal (F), and Program Name	Comments
FSU School	4	Shumard Oak Blvd	Tallahassee	32311	R	P	244	14,660		244		
FSU School	8	Shumard Oak Blvd	Tallahassee	32311	R	P	214	12,860		214		
Kate Sullivan ES						P	0	0	116			
FSU School	3	shumard oak blvd	Tallahassee	32311	R	P	247	14,860		?	HMGP	
<b>Year 2012</b>	<b>SpNs Shelter Capacity In Spaces (meets ARC 4496)</b>	<b>SpNs Shelter Demand In Spaces</b>	<b>Surplus/ Deficit In Spaces</b>	<b>SpNs Shelter Capacity (ft2)</b>			<b>Surplus/ Deficit (ft2)</b>	<b>Result</b>				
Storm Category 4/5	705	1,425	-720	42,300			-43,200					

**2012 Statewide Emergency Shelter Plan**

**LEVY**

Name	Bldg. #	Address	City	Zip	Retrofitted (R) or New Construction (N)	General (G), PSN (P), Pet - Friendly (A)	Total Risk Capacity In People (Meets ARC 4496)	Total Risk Capacity (ft <sup>2</sup> ) (Meets ARC 4496)	Risk Capacity In People (Does not Meet ARC 4496 or Not Yet Surveyed)	Local Planned Usage (reported capacity)	Funding Source: Local (L), State (S), Federal (F), and Program Name	Comments
Bronson ES	6	400 Ishie Ave	Bronson	32621	R	P	0	0	1,623	622	S-1435A-2003	Spns see below
Bronson ES	7	400 Ishie Ave	Bronson	32621	R	P	0	0		580	S-1435A-2003	Spns see below
Bronson ES		400 Ishie Ave	Bronson	32621		G	0	0	2,720			
Bronson MS/HS	café/600	8691 NE 90th str	Bronson	32621	N	G	276	5,520				
Bullock ES	5	130 Southwest 3rd. Strret	Williston	32696	R	G	525	4,897		525	S-1435A-2003	
Cedar Key School		951 Whiddon Avenue	Cedar Key	32625		G	0	0	0			in cat 2/3 zone
Chiefland Elementary School	100	1205 NW 4th Avenue	Chiefland	32626		P	0	0	1,687	60		per state study
Chiefland Elementary School	200	1205 NW 4th Avenue	Chiefland	32626	R	P	478	7,186		666	S-1467	per state study
Chiefland Elementary School	300	1205 NW 4th Avenue	Chiefland	32626	R	P	440	8,800		443	S-1588-2006	per state study
Chiefland Elementary School	400	1205 NW 4th Avenue	Chiefland	32626		P	0	0		43		per state study
Chiefland High School		808 N. Main Street	Chiefland	32626		G	0	0	2,201			
Chiefland Middle School		118 NW 4th Drive	Chiefland	32626		G	0	0	944			
Joyce Bullock Elementary School		130 Southwest 3rd. Strret	Williston	32696		G	0	0	0			same as Bullock ES
Williston Elementary School		801 South Main Street	Williston	32696		G	0	0	2,271			
Williston High School	6	427 West Noble Avenue	Williston	32696	R	G	292	4,374		488	S-1435A-2003	
Williston Middle School	12	20550 NE 3rd Avenue	Williston	32696	R	G	400	5,996		495	S-1467	
Williston Middle School	10-health	20550 NE 3rd Avenue	Williston	32696	R	G	62	926		130	S-1467	
Yankeetown School		4500 Highway 40 West	Yankeetown	34498		G	0	0	0			in cat 2 zone
							0	0				
<b>TOTALS FOR LEVY COUNTY</b>							<b>2,473</b>	<b>37,699</b>	<b>11,446</b>	<b>4,052</b>		<b>0</b>
<b>Year 2012</b>	<b>Shelter Capacity In People</b>	<b>Shelter Demand In People</b>	<b>Surplus/ Deficit In People</b>	<b>Shelter Capacity (ft2)</b>			<b>Surplus/ Deficit (ft2)</b>	<b>Result</b>				
Storm Category 4/5	2,473	4,308	-1,835	37,699			-48,461					
<b>Special Needs Storm Shelters</b>												
<b>Name</b>	<b>Bldg #</b>	<b>Address</b>	<b>City</b>	<b>Zip</b>			<b>SpNS Capacity (spaces @ 60sf) (meets ARC 4496)</b>	<b>SpNs Capacity (sf) (meets ARC 4496)</b>	<b>SpNS Capacity (spaces @ 60sf) (does not meet ARC 4496)</b>	<b>Local Planned Usage</b>		
Bronson ES	6	400 Ishie Ave	Bronson	32621	R	P	35	2,125		35		
Bronson ES	7	400 Ishie Ave	Bronson	32621	R	P	101	6,084		101		
<b>Year 2012</b>	<b>SpNs Shelter Capacity In Spaces (meets ARC 4496)</b>	<b>SpNs Shelter Demand In Spaces</b>	<b>Surplus/ Deficit In Spaces</b>	<b>SpNs Shelter Capacity (ft2)</b>			<b>Surplus/ Deficit (ft2)</b>	<b>Result</b>				
Storm Category 4/5	136	19	117	8,160			7,020					



**2012 Statewide Emergency Shelter Plan**

**LIBERTY**

Name	Bldg. #	Address	City	Zip	Retrofit ted (R) or New Constr uction (N)	General (G), PSN (P), Pet - Friendly (A)	Total Risk Capacity In People (Meets ARC 4496)	Total Risk Capacity (ft <sup>2</sup> ) (Meets ARC 4496)	Risk Capacity In People (Does not Meet ARC 4496 or Not Yet Surveyed)	Local Planned Usage (reported capacity)	Funding Source: Local (L), State (S), Federal (F), and Program Name	Comments
Bristol Pentecostal Holiness Church		Solomon Street	Bristol	32321			0	0	50			
Camp Woodmen		SR 12	Hosford	32324			0	0	100			
First Baptist Church		SR 20	Bristol	32321			0	0	100			
Hosford Junior High	14	HIGHWAY 20	HOSFORD	32334			0	0				
Liberty County High School		SR 20	Bristol	32321			0	0			L	
Liberty County Senior Center	1	SR 20	Bristol	32321			17	1,020			L	
W R Toler Elementary School	4-Gym	SR 12	Bristol	32321	R	G	352	7,613		352		Updated Fish Data
W R Toler Elementary School	2	SR 12	Bristol	32321	N	G	534	8,011		548	L	Updated Fish Data
W R Toler Elementary School	1	SR 12	Bristol	32321	R	G	185	3,707	547	185	1508-2005?	Updated Fish Data
W R Toler Elementary School	3	SR 12	Bristol	32321	R	G	63	1,262	317	63	1508-2005?	Updated Fish Data
<b>TOTALS FOR LIBERTY COUNTY</b>							<b>1,151</b>	<b>21,613</b>	<b>1,114</b>	<b>1,148</b>		<b>0</b>

Year 2012	Shelter Capacity In People	Shelter Demand In People	Surplus/ Deficit In People	Shelter Capacity (ft2)		Surplus/ Deficit (ft2)	Result			
Storm Category 4/5	1,151	214	937	21,613		17,333				

<b>Special Needs Storm Shelters</b>												
Name	Bldg #	Address	City	Zip			SpNS Capacity (spaces @ 60sf) (meets ARC 4496)	SpNs Capacity (sf) (meets ARC 4496)	SpNS Capacity (spaces @ 60sf) (does not meet ARC 4496)	Local Planned Usage (reported capacity)	Funding Source: Local (L), State (S), Federal (F), and Program Name	Comments
Hosford Junior High	14-Cafeteria	HIGHWAY 20	HOSFORD	32334	N	P	76	4,579		25		per ehpa list
							0	0		0		

Year 2012	SpNs Shelter Capacity In Spaces (meets ARC 4496)	SpNs Shelter Demand In Spaces	Surplus/ Deficit In Spaces	SpNs Shelter Capacity (ft2)		Surplus/ Deficit (ft2)	Result			
Storm Category 4/5	76	130	-54	4,560		-3,240				

**2012 Statewide Emergency Shelter Plan**

**MADISON**

Name	Bldg. #	Address	City	Zip	Retrofitted (R) or New Construction (N)	General (G), PSN (P), Pet - Friendly (A)	Total Risk Capacity In People <i>(Meets ARC 4496)</i>	Total Risk Capacity (ft <sup>2</sup> ) <i>(Meets ARC 4496)</i>	Risk Capacity In People <i>(Does not Meet ARC 4496 or Not Yet Surveyed)</i>	Local Planned Usage (report capacity)	Funding Source: Local (L), State (S), Federal (F), and Program Name	Comments
Greenville Elementary School		SR 150 S	Greenville	32331			0	0				
Lee Elementary School		731 US Hwy 90 E	Lee	32059			0	0				
Madison Central School	1	2093 W US Hwy 90	Madison	32340	R	G	175	2,621		518	S-1435A-2003	updated FISH Data
Madison Central School	2	2093 W US Hwy 90	Madison	32340	R	G	19	285		721	S-1435A-2003	updated FISH Data
Madison Central School	3	2093 W US Hwy 90	Madison	32340	R	G	65	972		490	S-1435A-2003	updated FISH Data
Madison Central School	4	2093 W US Hwy 90	Madison	32340	R	G	134	2,014		265	S-1435A-2003	updated FISH Data
Madison Central School	5	2093 W US Hwy 90	Madison	32340	R	G	511	7,661		833	S-1435A-2003	updated FISH Data
Madison Central School	6	2093 W US Hwy 90	Madison	32340	R	G	444	6,666		768	S-1435A-2003	updated FISH Data
Madison Central School	7	2093 W US Hwy 90	Madison	32340	R	G	429	6,435		728	S-1435A-2003	updated FISH Data
Madison Central School	8	2093 W US Hwy 90	Madison	32340	R	G	563	8,442		796	S-1435A-2003	updated FISH Data
Madison Central School	9	2093 W US Hwy 90	Madison	32340	R	G	478	7,177		659	S-1435A-2003	updated FISH Data
Madison Central School	10	2093 W US Hwy 90	Madison	32340	R	G	622	9,323		802	S-1435A-2003	updated FISH Data
Madison Central School	11	2093 W US Hwy 90	Madison	32340	R	G	344	5,153		518	S-1435A-2003	updated FISH Data
Madison Central School	12	2093 US Hwy 90 W	Madison	32340			0	0				FISH Data = 12,019 sqft
Madison County High School		US Highway 90 East	Madison	32340			0	0	350			
Madison county Memorial Hospital		201 E Marion St	Madison	32340			0	0				
Mormon Church, Madison		US Highway 90 East	Madison	32340			0	0	70			0
New Testament Christian Center		us Highway 90 East	Madison	32340			0	0	100			0
Pinetta ES	3	3rd Street	Pinetta	32350	R	G	124	2,479			S-1496-2009	updated FISH Data
Town of Lee-Publ. Saf/Emerg Shel	Fire		Lee	32059	N	G	300	4,632		300	S-EMPA	01CP-04-03-50-02-217
<b>TOTALS FOR MADISON COUNTY</b>							<b>4,208</b>	<b>63,860</b>	<b>520</b>	<b>7,398</b>		<b>0</b>

Year 2012	Shelter Capacity In People	Shelter Demand In People	Surplus/ Deficit In People	Shelter Capacity (ft2)	Surplus/ Deficit (ft2)	Result
Storm Category 4/5	4,208	1,239	2,969	63,860	39,080	

**Special Needs Storm Shelters**

Name	Bldg #	Address	City	Zip	R	P	SpNs Capacity (spaces @ 60sf) (meets ARC 4496)	SpNs Capacity (sf) (meets ARC 4496)	SpNs Capacity (spaces @ 60sf) (does not meet ARC 4496)	Local Planned Usage (report capacity)	Funding Source: Local (L), State (S), Federal (F), and Program Name	Comments
Madison Central	?	2093 W US Hwy 90	Madison	32340	R	P	28	1,680		28		Building # not verified
							0	0				

Year 2012	SpNs Shelter Capacity In Spaces (meets ARC)	SpNs Shelter Demand In Spaces	Surplus/ Deficit In Spaces	SpNs Shelter Capacity (ft2)	Surplus/ Deficit (ft2)	Result
Storm Category 4/5	28	75	-47	1,680	-2,820	

2012 Statewide Emergency Shelter Plan

MANATEE												
Name	Bldg. #	Address	City	Zip	Retr ofite d (R) or New Const ruction	Gener al (G), PSN (P), Pet - Frien dly	Total Risk Capacity In People (Meets ARC 4496)	Total Risk Capacity (ft <sup>2</sup> ) (Meets ARC 4496)	Risk Capacity In People (Does not Meet ARC 4496 or Not Yet Surveyed)	Local Planned Usage (reported capacity)	Funding Source: Local (L), State (S), Federal (F), and Program Name	Comments
Ana Maria Elementary	1	4700 Gulf Drive North	Holmes Beach	34217	N	O	0	0			L,S	Exempted, in Category A Zone., 14.6' SLOSH
Annie Lucy Williams Elementary	1	3404 Fort Hamer Road	Parrish	34219	N	G	1,451	32,280		1,450	L,S	Updated FISH Data
Bashaw Elementary School	2	3515 Morgan Johnson Rd	Bradenton	34208	R	G	0	0		500	S-1543	Updated FISH Data, 4.4' SLOSH
Bashaw Elementary School	3	3515 Morgan Johnson Rd	Bradenton	34208	R	G	0	0		500	HMGP	Updated FISH Data, 4.4' SLOSH
Bashaw Elementary School	4	3515 Morgan Johnson Rd	Bradenton	34208	R	G	0	0		460	HMGP	Updated FISH Data, 4.4' SLOSH
Bashaw Elementary School	5	3515 Morgan Johnson Rd	Bradenton	34208	R	G	0	0		460	HMGP	Updated FISH Data, 4.4' SLOSH
Bayshore Elementary School	1	6120 26th Street West	Bradenton	34207	N	G	1,764	40,767		1,764	L	Updated FISH Data
Braden River Elementary School	1	6215 River Club Boulevard	Bradenton	34208	R	G	361	7,757		361	HMGP	Updated FISH Data
Braden River Elementary School	2	6215 River Club Boulevard	Bradenton	34208	R	G	448	6,713		507	HMGP	Updated FISH Data
Braden River Elementary School	3	6215 River Club Boulevard	Bradenton	34208	R	G	460	6,899		501	S-1543	Updated FISH Data
Braden River Elementary School	4	6215 River Club Boulevard	Bradenton	34208	R	G	291	4,358		460	S-1543	Updated FISH Data
Braden River Elementary School	5	6215 River Club Boulevard	Bradenton	34208	R	G	465	7,651		465	S-1543	Updated FISH Data
Braden River High School	6	6545 SR 70 East	Bradenton	34202	N	G	718	11,131		718	L	Updated FISH Data
Braden River High School	7	6545 SR 70 East	Bradenton	34202	N	G	1,335	20,028		1,714	L	Updated FISH Data
Braden River High School	8	6545 SR 70 East	Bradenton	34202	N	G,A	619	9,283		937	L	Updated FISH Data
Braden River Middle School	2	6215 River Club Boulevard	Bradenton	34202	R	G	447	9,351		447	HMGP	Updated FISH Data
Braden River Middle School	5	6215 River Club Boulevard	Bradenton	34202	R	G	168	2,518		183	S-1543	Updated FISH Data
Braden River Middle School	6	6215 River Club Boulevard	Bradenton	34202	R	G	354	6,447		354	S-1543	Updated FISH Data
Buffalo Creek MS	1	7320 69th	Palmetto	34220	N	G	153	3,050				Updated FISH Data
Carlos Haile Middle School	5	9501 State Road 64th East	Bradenton	34202	R	G	531	7,958		588	S-1118A	Updated FISH Data
Carlos Haile Middle School	3A	9501 State Road 64th East	Bradenton	34202	R	G	668	16,695		297	HMGP	Updated FISH Data
Carlos Haile Middle School	4A	9501 State Road 64th East	Bradenton	34202	R	G	619	9,287		747	HMGP	Updated FISH Data
Daughtrey Elementary	1	515 63rd Avenue East	Bradenton	34202	N	G	1,877	37,552		1,877	L	
Freedom Elementary	1	9515 State Road 64th East	Bradenton	34202	N	G	1,764	37,095		1,764	L	Updated FISH Data
G.D. Rogers garden ELE	2	515 13th Avenue West	Bradenton	34208	N	G	0	0	0	1,450	L,S	Updated FISH Data, 3.3' SLOSH
Gullett ES	1	12125 44th	Bradenton	34202	N	G	1,799	35,984				Updated FISH Data
King Middle School	1	700 75th Street NW	Bradenton	34209	N	O	0	0	0		L,S	Exempted, In Catatgory B Evacuation Zone, 8.3' SLOSH
Kinnan Elementary School	3	3415 Tallevast Road	Sarasota	34243	R	G	0	0		530	S-1523	Updated FISH Data, 3.5' SLOSH
Kinnan Elementary School	4	3415 Tallevast Road	Sarasota	34243	R	G	0	0		145	HMGP	Updated FISH Data, 3.5' SLOSH
Lee Middle School	A	4000 53rd Avenue West	Bradenton	34210	R	G	326	7,849		326	S-1543	
Lee Middle School	B	4000 53rd Avenue West	Bradenton	34210	R	G	326	7,132		326	S-1543	
Lee Middle School	C	4000 53rd Avenue West	Bradenton	34210	R	G	326	7,790		326	S-1543	
Lincoln Middle School	A	305 17th Street East	Palmetto	34221	R	G	0	0		326	HMGP	6.3' SLOSH
Lincoln Middle School	B	305 17th Street East	Palmetto	34221	R	G	0	0		326	HMGP	6.3' SLOSH
Lincoln Middle School	C	305 17th Street East	Palmetto	34221	R	G	0	0		326	HMGP	6.3' SLOSH
Louise Johnson Middle School	3	2121 26th Avenue East	Bradenton	34208	R	G	431	12,509		198	F,S	not done?
Louise Johnson Middle School	5	2121 26th Avenue East	Bradenton	34208	R	G	198	2,712		198	S-1543	
Manatee Community College		5840 26th Street West	Bradenton	34210			0	0	173			
Manatee High School	2	1000 32nd Street West	Bradenton	34205	R	G	1,293	23,898		1,293	HMGP	Updated FISH Data
Manatee High School	3	1000 32nd Street West	Bradenton	34205	R	G,A	663	16,585		560	S-1543	Updated FISH Data
Manatee Technical Institute Medical Complex	1	5520 Lakewood Ranch	Bradenton	34202	N	P	0	0			EMPA	
McNeil Elementary	1	6325 Lorraine Road	Bradenton	34202	N	G	1,766	37,095		1,766	L	Updated FISH Data
Miller ES	1	4201 Manatee	Bradenton	34209	N	G	2,080	41,605				Updated FISH Data
Mills Elementary School	1	7200 69th Street East	Palmetto	34221	N	G,A	1,588	39,695		1,484	L	Updated FISH Data
Myakka Elementary School	3	37205 Manatee Avenue	Myakka City	34251	R	G	217	3,250		290	HMGP	Updated FISH Data
Myakka Elementary School	4	37205 Manatee Avenue	Myakka City	34251	R	G	96	1,441		155	HMGP	Updated FISH Data
Myakka Elementary School	6	37205 Manatee Avenue	Myakka City	34251	R	G	221	3,316		293	HMGP	Updated FISH Data
Myakka Elementary School	7	37205 Manatee Avenue	Myakka City	34251	R	G	108	1,622		127	HMGP	Updated FISH Data
R. Dan Nolan Middle School	1	6615 Greenbrook Boulevard	Bradenton	34202	N	G	0	0		3,377	L	Total used for SPNS
Oneco Elementary School	1	2000 53rd Avenue East	Bradenton	34203	R	G	0	0			HMGP	
Oneco Elementary School	4	2000 53rd Avenue East	Bradenton	34203	R	G	564	14,102		303	S-1543	Updated FISH Data
Oneco Elementary School	6	2000 53rd Avenue East	Bradenton	34203	R	G	501	12,523		297	S-1543	Updated FISH Data
Palmetto Elementary School	4	634 7th Street West	Palmetto	34221	R	G	0	0			HMGP	not shelter, 4.2' SLOSH
Palmetto Elementary School	5	634 7th Street West	Palmetto	34221	R	G	0	0			HMGP	not shelter, 4.2' SLOSH
Palmetto Elementary School	6	634 7th Street West	Palmetto	34221	R	G	0	0			HMGP	not shelter, 4.2' SLOSH
Prine Elementary School	1	3801 Southern Paerkway	Bradenton	34205	N	G	2,054	37,733		2,054	L	Updated FISH Data
Rowlett Elementary School	1	3500 9th Street East	Bradenton	34208	N	G	0	0			F,S	not done?
Rowlett Elementary School	3	3500 9th Street East	Bradenton	34208	N	G	616	15,410		530	HMGP	Updated FISH Data

**2012 Statewide Emergency Shelter Plan**

<b>MANATEE</b>												
Rowlett Elementary School	4	3500 9th Street East	Bradenton	34208	R	G	0	0	0	0		
Rowlett Addition	6	3500 9th Street East		34208	N	G	425	7,075	0	425	L S	Updated FISH Data
Seabreeze Elementary School	1	3601 71st Street West	Bradenton	34209	R	G	0	5,968		0	HMGP	Updated FISH Data
Seabreeze Elementary School	2	3601 71st Street West	Bradenton	34209	R	G	449	6,736		520	S-1118A	Updated FISH Data
Seabreeze Elementary School	3	3601 71st Street West	Bradenton	34209	R	G	437	6,559		521	HMGP	Updated FISH Data
Seabreeze Elementary School	4	3601 71st Street West	Bradenton	34209	R	G	353	5,294		460	HMGP	Updated FISH Data
Seabreeze Elementary School	5	3601 71st Street West	Bradenton	34209	R	G	465	7,628		465	HMGP	Updated FISH Data
Tillman Elementary School	3	1415 29th Street East	Palmetto	34221	R	G	0	0		530	HMGP	Updated FISH Data, 1.1' SLOSH
Tillman Elementary School	4	1415 29th Street East	Palmetto	34221	R	G	0	0		145	HMGP	Updated FISH Data, 1.1' SLOSH
Willis Elementary School	1	Lorraine Road	Bradenton	34202	N	G	1,764	42,938		1,764	L S	Updated FISH Data
Witt Elementary School	3	200 Rye Road	Bradenton	34202	R	G	0	0		520	HMGP	Updated FISH Data, 10.1' SLOSH
Witt Elementary School	4	200 Rye Road	Bradenton	34202	R	G	0	0		418	HMGP	Updated FISH Data, 10.1' SLOSH
Witt Elementary School	5	200 Rye Road	Bradenton	34202	R	G	0	0		394	HMGP	Updated FISH Data, 10.1' SLOSH
<b>TOTALS FOR MANATEE COUNTY</b>							<b>33,559</b>	<b>681,269</b>	<b>173</b>	<b>40,222</b>		<b>0</b>
<b>Year 2012</b>	<b>Shelter Capacity In People</b>	<b>Shelter Demand In People</b>	<b>Surplus/ Deficit In People</b>	<b>Shelter Capacity (ft2)</b>			<b>Surplus/ Deficit (ft2)</b>	<b>Result</b>				
Storm Category 4/5	33,559	19,441	14,118	681,269			292,449					
<b>Special Needs Storm Shelters</b>												
<b>Name</b>	<b>Bldg #</b>	<b>Address</b>	<b>City</b>	<b>Zip</b>			<b>SpNS Capacity (spaces @ 60sf) (meets ARC 4496)</b>	<b>SpNs Capacity (sf) (meets ARC 4496)</b>	<b>SpNS Capacity (spaces @ 60sf) (does not meet ARC 4496)</b>	<b>local planned usage</b>	<b>Funding Source: Local (L), State (S), Federal (F), and Program Name</b>	<b>Comments</b>
Manatee Tech Inst	1	5520 Lakewood Ranch	Bradenton	34202	N	P	193	11,788		193		Updated FISH Data
R. Dan Nolan MS	1	6615 Greenbrook Boulevard	Bradenton	34202	N	P	740	59,175		571		
<b>Year 2012</b>	<b>SpNs Shelter Capacity In Spaces (meets ARC 4496)</b>	<b>SpNs Shelter Demand In Spaces</b>	<b>Surplus/ Deficit In Spaces</b>	<b>SpNs Shelter Capacity (ft2)</b>			<b>Surplus/ Deficit (ft2)</b>	<b>Result</b>				
Storm Category 4/5	933	2,193	-1,260	55,980			-75,600					

2012 Statewide Emergency Shelter Plan

MARION

Name	Bldg. #	Address	City	Zip	Retrofitted (R) or New Construction (N)	General (G), PSN (P), Pet-Friendly (A)	Total Risk Capacity In People (Meets ARC 4496)	Total Risk Capacity (ft <sup>2</sup> ) (Meets ARC 4496)	Risk Capacity In People (Does not Meet ARC 4496 or Not Yet Surveyed)	Local Planned Usage (reported capacity)	Funding Source: Local (L), State (S), Federal (F), and Program Name	Comments
Bellevue High School, Bldg 10	10	10400 SE 36th Avenue	Bellevue	34420	R/N	P	0	0		111	S, L	change to SpNS
Bellevue High School, Bldg 3	3	10400 SE 36th Avenue	Bellevue	34420	R/N	P	0	14,884	0	32	S, L	changed to SpNS
Bellevue High School, Bldg 4	4	10400 SE 36th Avenue	Bellevue	34420	R/N	P	0	14,213	0	128	S, L	changed
Bellevue High School, Bldg 5	5	10400 SE 36th Avenue	Bellevue	34420	R/N	P	0	0		46	S, L	change to SpNS
Bellevue Middle School	2	10500 SE 36th Avenue	Bellevue	34420	R	G	473	11,369		473	HMGP	Updated FISH
Bellevue Middle School	3	10500 SE 36th Avenue	Bellevue	34420	R	G	430	11,206		430	HMGP	Updated FISH
Bellevue Middle School	4	10500 SE 36th Avenue	Bellevue	34420	R	P	0	0			HMGP	change to SpNS
Bellevue Middle School	8-gym	10500 SE 36th Avenue	Bellevue	34420		G	0	0		1,529		11,249 sqft per FISH Not 4496
Dunnellon High School	23	10055 SW 180th Ave Rd	Dunnellon	34432		G	251	6,125		251	S-1523-2002	
Dunnellon High School	24	10055 SW 180th Ave Rd	Dunnellon	34432		G	334	6,363		334	S-1523-2002	
Dunnellon Middle School		21005 Chestnut Street	Dunnellon	34432		G	0	0	309			
East Marion Elementary School		14550 NE 14th St Rd	Silver Springs	34488			0	0				
Eighth Street Elementary School		513 SE 8th Street	Ocala	34470			0	0				
Emerald Shores Elementary School		404 Emerald Road	Ocala	34472			0	0				
Evergreen Elementary School		4000 NE W Anthony Road	Ocala	34471			0	0				
Fessenden Elementary School		4200 NW 90th Street	Ocala	34470			0	0				
First Baptist Church of Bellevue		6107 SE Agnew Road	Bellevue	34420			0	0				
Forest High School --Gym	4	5000 SE Maricamp	Ocala	34480	N	G	853	21,337		638	S, L	
Forest High School -- Music & Band Room	3	5000 SE Maricamp	Ocala	34480	N	G	454	11,345		267	S, L	
Forest High School --Cafeteria	2	5000 SE Maricamp	Ocala	34480	N	G	328	5,910		328	S, L	
Fort King Middle School		545 NE 17th Avenue	Ocala	34470		G	0	0				
Fort McCoy Elementary/Middle School		16160 N Highway 315	Fort McCoy	32134		G	0	0	765	765		
Fort McCoy School	4	16160 N Highway 315	Fort McCoy	32134	R	G	214	4,592		214	HMGP	
Fort McCoy School	5	16160 N Highway 315	Fort McCoy	32134	R	G	155	3,873		123	HMGP	
Fort McCoy School	6	16160 N Highway 315	Fort McCoy	32134	R	G	214	4,592		214	HMGP	
Fort McCoy School	8	16160 N Highway 315	Fort McCoy	32134	R	G	214	4,592		214	HMGP	
Greenway Elementary School		207 Midway Road	Ocala	34472		G	0	0				
Hammitt Bowen ES		4397 SW 95th Street	Ocala	34476	N	G	1,432	35,799		1,249		
Horizon Academy (4-8 Mid school)	1	365 Marion Oaks Drive	Ocala	34473	N	G	1,012	25,290		755	L	
Lake Weir High School	3	10351 SE Maricamp Road	Ocala	34472	R	G	1,242	27,844		1,242	HMGP	per schoolboard
Lake Weir HS (renovation)	2	10351 SE Maricamp Road	Ocala	34472	R	G	304	11,108		304	L	per schoolboard
Lake Weir Middle School		10220 SE Sunset Harbor	Summerfield	34491		G	0	0				
Liberty MS (Middle School CC)	1	4773 SW 95th Street	Ocala	34476	N	G	952	23,802		832	L	
Madison Street Elementary School	1	1239 NW 4th Street	Ocala	34470	N	G	0	0		370	S, L	
Maplewood Elementary School		4751 SE 24th Street	Ocala	34470		G	0	0	100			
Maplewood Elementary School		4751 SE 24th Street	Ocala	34470		G	0	0	350			
Marion Institute of Technology (Old Forest HS)		1614 SE Fort King Street	Ocala	34470			0	0				
North Marion High School		151 W Highway 329	Citra	32113			0	0				
North Marion Middle School	café	2085 NW 28th Street	Ocala	32113	N	G	227	4,540		227		per schoolboard 2009
Oakcrest Baptist Church		1109 NE 28th Street	Ocala	34470			0	0				
Oakcrest Elementary School		1112 NE 28th Street	Ocala	34470			0	0				
Ocala City Auditorium		836 NE Sanchez Avenue	Ocala	34470			0	0				
Ocala Springs Elementary School		5757 NE 40th Ave Rd	Ocala	34470			0	0				
Osceola Middle School		526 SE Tusawilla Avenue	Ocala	34471			0	0				
Phoenix Center		2091 NE 35th Street	Ocala	34470			0	0				
Queen of Peace Catholic Church		6455 SW SR 200	Ocala	33474			0	0				
Reddick Collier Elementary School		4595 W Highway 316	Reddick	32686			0	0				
Romeo Elementary School		19550 SW 36th Street	Dunnellon	34432			0	0				

**2012 Statewide Emergency Shelter Plan**

**MARION**

Name	Bldg. #	Address	City	Zip	Retrofitted (R) or New Construction (N)	General (G), PSN (P), Pet-Friendly (A)	Total Risk Capacity In People (Meets ARC 4496)	Total Risk Capacity (ft <sup>2</sup> ) (Meets ARC 4496)	Risk Capacity In People (Does not Meet ARC 4496 or Not Yet Surveyed)	Local Planned Usage (reported capacity)	Funding Source: Local (L), State (S), Federal (F), and Program Name	Comments
Saddlewood Elementary School, Bldg 1	1	3700 SW 43rd Court	Ocala	34473	N	G	0	2,028			S, L	changed to media center/admin
Saddlewood Elementary School, Bldg 4	4	3700 SW 43rd Court	Ocala	34473	N	G	219	4,592		196	S, L	
Saddlewood Elementary School, Bldg 6	6	3700 SW 43rd Court	Ocala	34473	N	G	152	3,760		152	S, L	cafeteria
Shady Hill Elementary School		5959 S Magnolia Avenue	Ocala	34470			0	0				
South Ocala Elementary School		2831 SE Lake Weir Avenue	Ocala	34470			0	0				
Sparr Elementary School		2525 E Highway 329	Ocala	32192			0	0				
St. Jude Catholic Community Church		443 Marion Oaks Drive	Ocala	34474			0	0				
Stanton-Weirsdale Elementary School		16700 SE 134th Terrace	Weirsdale	32195			0	0				
Sunrise Elementary School		375 Marion Oaks Course	Ocala	34473			0	0				
Vanguard High School	1	7 NW 28th Street	Ocala	34470	R	G	1,044	20,880		1,032	F,S	per schoolboard
Vanguard HS (new)	2	7 NW 28th Street	Ocala	34470	N	G	387	5,810		227	L	
Vanguard HS (new)	3	7 NW 28th Street	Ocala	34470	N	G	387	5,812		176		
Vanguard HS (New)	5	7 NW 28th Street	Ocala	34470	N	G	386	5,789		274		
Vanguard HS (new)	4	7 NW 28th Street	Ocala	34470		G,A	0	0				Pets Only
Westport HS	1	3733 SW 80th Avenue	Ocala	34482	N	G	563	11,261		572	S, L	
<b>TOTALS FOR MARION COUNTY</b>							<b>12,227</b>	<b>308,716</b>	<b>1,524</b>	<b>13,705</b>		<b>0</b>

Year 2012	Shelter Capacity In People	Shelter Demand In People	Surplus/ Deficit In People	Shelter Capacity (ft2)	Surplus/ Deficit (ft2)	Result
Storm Category 4/5	12,227	21,235	-9,008	308,716	-115,984	

**Special Needs Storm Shelters**

Name	Bldg #	Address	City	Zip	SpNS Capacity (spaces @ 60sf) (meets ARC 4496)	SpNs Capacity (sf) (meets ARC 4496)	SpNS Capacity (spaces @ 60sf) (does not meet ARC 4496)	Local Planned Usage (reported capacity)	Funding Source: Local (L), State (S), Federal (F), and Program Name	Comments
Westport HS (Gym)	1	3733 SW 80th Avenue	Ocala	34482		0	0	122		
Bellview HS	3	10400 SE 36th Avenue	Belleview	34420	P	32	14,884	19	S/L	
Bellview HS	5	10400 SE 36th Avenue	Belleview	34420	P	122	9,750	61		
Bellview HS	10	10400 SE 36th Avenue	Belleview	34420	P	183	14,603	96		
Bellview HS	4	10400 SE 36th Avenue	Belleview	34420	P	236	14,213	115		
Bellview HS	8	10400 SE 36th Avenue	Belleview	34420	P	0	0	500		Not 4496?
Bellview MS	4	10500 SE 36th Avenue	Belleview	34420	P	157	10,965	157		

Year 2012	SpNs Shelter Capacity In Spaces (meets ARC 4496)	SpNs Shelter Demand In Spaces	Surplus/ Deficit In Spaces	SpNs Shelter Capacity (ft2)	Surplus/ Deficit (ft2)	Result
Storm Category 4/5	852	107	745	51,120	44,700	

**2012 Statewide Emergency Shelter Plan**

**MARTIN**

Name	Bldg. #	Address	City	Zip	Retrofitted (R) or New Construction (N)	General (G), PSN (P), Pet - Friendly (A)	Total Risk Capacity In People (Meets ARC 4496)	Total Risk Capacity (ft <sup>2</sup> ) (Meets ARC 4496)	Risk Capacity In People (Does not Meet ARC 4496 or Not Yet Surveyed)	Local Planned Usage (reported capacity)	Funding Source: Local (L), State (S), Federal (F), and Program Name	Comments
Bessey Creek Elementary School		2201 SW Matheson Ave	Palm City	34990	R	G	850	17,000		850	F/S	
Challenger School		5200 SE Willoughby Blvd	Stuart	34987	R	P	0	0			F/S	SpNS.
Citrus Grove Elementary	1	2527 SW Citrus Blvd.	Palm City	34990	N	G	1,300	2,600	0	1,300		expected 2011.
Crystal Lake Elementary School		2095 SW 96th Street	Stuart	34997	R	G	849	16,980		0	F/S	local staffing unavailable.
Felix Williams School		401 NW Baker Street	Stuart	34994	R	G	0	0		850		pot 2.3 ft of surge . 6.072 elev.
Hidden Oaks Middle School	2	2801 SW Martin Highway	Palm City	34990	R	G	1,036	20,720		1,036	F/S	per PBSJ report.
Hidden Oaks Middle School	3	2801 SW Martin Highway	Palm City	34990	R	G	1,000	20,000		1,000		per PBSJ report.
Hidden Oaks Middle School	4&5	2801 SW Martin Highway	Palm City	34990	R	G	782	15,640				per PBSJ report.
Hidden Oaks Middle School	6	2801 SW Martin Highway	Palm City	34990	R	G	421	8,420				per PBSJ report.
Hidden Oaks Middle School	7	2801 SW Martin Highway	Palm City	34990	R	G	963	19,260				per PBSJ report.
Hidden Oaks Middle School	8	2801 SW Martin Highway	Palm City	34990	R	G	597	11,940				per PBSJ report.
Indiantown Middle School	2	16303 SW Farm Road	Indiantown	34956	N	G	1,050	18,823		150	L	
JD Parker ES	entire	1050 East 10th St	Stuart	34996	N	G	1,940	47,434		0	F/S	
Jensen Beach Elementary School		2525 NE Savanna Road	Jensen Beach	34857	R	G	1,300	29,000		0	F/S	
Jensen Beach HS	4	2875 Goldenrod Rd	Jensen Beach	34957	N	G	3,500	62,054		3,500	F/S	AS-IS.
Jensen Beach HS	3	2875 Goldenrod Rd	Jensen Beach	34957	N	G	1,247	24,936		0	L	
Jensen Beach HS	5	2876 Goldenrod Rd	Jensen Beach	34958	N	G	335	6,698		0		
Pinewood ES	2	5200 SE Willoughby Blvd	Stuart	34997		G	190	3,799				need to confirm ASCE-7.
Pinewood ES	3	5200 SE Willoughby Blvd	Stuart	34997		G	193	3,865				need to confirm ASCE-7.
Pinewood ES	4	5200 SE Willoughby Blvd	Stuart	34997		G	342	6,830				need to confirm ASCE-7.
Pinewood ES	7	5200 SE Willoughby Blvd	Stuart	34997		G	248	4,950				need to confirm ASCE-7.
Pinewood ES	8	5200 SE Willoughby Blvd	Stuart	34997		G	123	2,463				need to confirm ASCE-7.
Pinewood ES	9	5200 SE Willoughby Blvd	Stuart	34997		G	239	4,783				need to confirm ASCE-7.
Pinewood ES	10	5201 SE Willoughby Blvd	Stuart	34998	N	G	249	4,996				
Pt. Salerno ES	1	4890 SE Jack Ave	Stuart	34997	N	G	451	9,023		0	F/S	per PBSJ report.
Pt. Salerno ES	2	4890 SE Jack Ave	Stuart	34997	N	G	1,229	24,579		1,300		per PBSJ report.
Seawind Elementary School		3700 SE Seabranh Blvd	Stuart	33455	R	G	850	15,998		850	F/S	
Seawind Elementary School	9	3701 SE Seabranh Blvd	Stuart	33456	N	G	320	6,394				
South Fork		10205 SW Pratt & Whitney	Stuart	34997			0	0				not a hurricane shelter.
Warfield Elementary School	21	15261 SW 50th Street	Indiantown	34956	N	G	450	10,682		450	L	
							0	0				
<b>TOTALS FOR MARTIN COUNTY</b>							<b>22,054</b>	<b>419,867</b>	<b>0</b>	<b>11,286</b>		<b>0</b>

Year 2012	Shelter Capacity In People	Shelter Demand In People	Surplus/ Deficit In People	Shelter Capacity (ft2)	Surplus/ Deficit (ft2)	Result
Storm Category 4/5	22,054	4,246	17,808	419,867	334,947	

**Special Needs Storm Shelters**

Name	Bldg #	Address	City	Zip		SpNS Capacity (spaces @ 60sf) (meets ARC 4496)	SpNs Capacity (sf) (meets ARC 4496)	SpNS Capacity (spaces @ 60sf) (does not meet ARC 4496)	Local Planned usage	Funding Source: Local (L), State (S), Federal (F), and Program Name	Comments
Challenger School ES		5200 SE Willoughby Blvd	Stuart	34987		P	300	18,000	300		
David L. Anderson MS	1 - Aud. & Cafet.	7000 Sw Atlantic Ridge Dr	Stuart	34997		P	142	8,563			
David L. Anderson MS	2	7001 Sw Atlantic Ridge Dr	STUART	34997	N	P	213	12,801			
David L. Anderson MS	3	7002 Sw Atlantic Ridge Dr	STUART	34997	N	P	218	13,085			

**2012 Statewide Emergency Shelter Plan**

**MARTIN**

David L. Anderson MS	4	7003 Sw Atlantic Ridge Dr	STUART	34997	N	P	223	13,370				
David L. Anderson MS	5- Gym	7000 Sw Atlantic Ridge Dr	Stuart	34997		P	273	16,412				
<b>Year 2012</b>	<b>SpNs Shelter Capacity In Spaces (meets ARC 4496)</b>	<b>SpNs Shelter Demand In Spaces</b>	<b>Surplus/ Deficit In Spaces</b>	<b>SpNs Shelter Capacity (ft2)</b>			<b>Surplus/ Deficit (ft2)</b>	<b>Result</b>				
Storm Category 4/5	1,369	1,885	-516	82,140			-30,960					



2012 Statewide Emergency Shelter Plan

MIAMI-DADE

Name	Bldg. #	Address	City	Zip	Retrofitted (R) or New Construction (N)	General (G), PSN (P), Pet-Friendly (A)	Total Risk Capacity In People (Meets ARC 4496)	Total Risk Capacity (ft <sup>2</sup> ) (Meets ARC 4496)	Risk Capacity In People (Does not Meet ARC 4496 or Not Yet Surveyed)	Local Planned Usage (reported capacity)	Funding Source: Local (L), State (S), Federal (F), and Program Name	Comments
American Senior High	1	12850 NW 67th Avenue	Miami	33015	R	G	4,014	100,340		2,558	S-1523-2002	updated F.I.S.H.
American Senior High	4	12850 NW 67th Avenue	Miami	33015	R	G	151	3,786		0	S-1523-2002	updated F.I.S.H.
Andover Middle School	3	121NE 207th Street	Miami	33179	N	G	356	7,136				per master list
Arvida Middle	1	10900 SW 127th Avenue	Miami	33186		G	0	0		700		in Cat 4 surge Zone
Ashe, Bowman Elementary School		6601 SW 152nd Avenue	Miami	33193		G	0	0		1,386		Per 2010 SESP, possible Cat 5 Zone
Bent Tree Elementary School	campus	4861 SW 140th Avenue	Miami	33175		G	0	0		474		F.I.S.H.;bldg# 3-12 (10 total), in Cat 5 Zone
Brentwood Elementary School	4	3131 NW 191st Street	Miami	33056		G	570	8,543		865	L	updated F.I.S.H.
Bright, James Elementary School		2530 W 10th Avenue	Hialeah	33010		G	0	0		1,208		Per 2010 SESP, possible Cat 4 Zone
Calusa Elementary		9580 W Calusa Club Drive	Miami	33186		G	0	0		900		Per 2010 SESP, Cat 4 Zone
Chiles, Lawton Middle School	2	8190 NW 197 Street	Miami	33015	N	G	1,436	34,122		1,436	L	Updated F.I.S.H. Data
Chiles, Lawton Middle School	3	8190 NW 197 Street	Miami	33015	N	G	817	16,342				Updated F.I.S.H. Data
Chiles, Lawton Middle School	4	8190 NW 197 Street	Miami	33015	N	G	392	7,842				Updated F.I.S.H. Data
Citrus Grove Middle School	1	21153 NW 3rd Street	Miami	33125	R	G	1,732	43,289		1,700	Hmgs	Updated F.I.S.H. Data
Citrus Grove Middle School	2	21153 NW 3rd Street	Miami	33125	R	G	1,063	26,565				Updated F.I.S.H. Data
Coral Gables SHS	15 (3story)	450 Bird Road	Coral Gables	33146	R	G	0	0			AS-IS	Updated F.I.S.H. Data, possible Cat 5 Zone
Country Club Middle	3	18305 NW 75 Place	Miami	33015	N	G	2,089	47,191		2,089		Updated F.I.S.H. Data
Doral Middle School		5005 NW 112 Avenue	Miami	33178	N,R?	G	1,360	27,200		1,360	L	per master list
Marjory Stoneman Douglas Elementary	campus	11901 SW 2nd Street	Miami	33184		G	1,569	31,380		1,569		per master list
Drew, Charles Middle School		1801 NW 60th Street	Miami	33142		G	1,050	21,000		1,050		Per 2010 SESP;Bldg#'s required
Dunbar Elementary School		505 NW 20th Street	Miami	33127		G	786	15,720		786		Per 2010 SESP;Bldg#'s required
Fascell, Dante Elementary School		15625 SW 80th Street	Miami	33193		G	0	0		931		Per 2010 SESP;Bldg#'s required, possible Cat 5 zone
Finlay, Carlos Elementary	1	851 SW 117 Avenue	Miami	33174		G	0	0		1,407		Updated F.I.S.H. Data, LPU total, possible Cat 5 zone
Finlay, Carlos Elementary	3	851 SW 117 Avenue	Miami	33174		G	0	0				Updated F.I.S.H. Data, possible Cat 5 Zone
Finlay, Carlos Elementary	4	851 SW 117 Avenue	Miami	33174		G	0	0				Updated F.I.S.H. Data, possible Cat 5 Zone
Florida Int University (Univ Park Camp	Dorms	11200 SW 8th Street	Miami	33165		G	0	0				For FIU students only
Goleman High School	8&9	14100 NW 89th Avenue	Miami	33016		G	1,356	25,059		1,356	s-1523-2002	
Goleman Senior High	1 & 4	14100 NW 89th Avenue	Miami	33016	R	G	2,465	61,621		800	s-1523-2002	
Goleman Senior High	12	14100 NW 89th Avenue	Miami	33016	R	G	0	6,645				
Greynolds Park Primary Learning Center		1575 NE 177 Street	N Miami Bea	33162		G	517	10,340		517		Per 2010 SESP;Bldg#'s required
Hall, Joe Elementary School	2 thru 8	1901 SW 134th Avenue	Miami	33175		G	914	20,907		914		no surge
Hammocks Middle School		9889 Hammocks Blvd	Miami	33196		G	0	0		1,467		Per 2010 SESP;Bldg#'s required, possible Cat 5 zone
Hartner Elementary School		401 NW 29th Street	Miami	33127		G	1,306	26,120		1,306		Per 2010 SESP;Bldg#'s required
Hialeah Gardens Senior High	7	11700 Hialeah Gardens Bl	Hialeah Gard	33018	N	G	2,934	58,688				per master list
Hialeah Senior		251 East 49 Street	Hialeah	33013	N	G	1,352	27,040		1,352	L	2010 SESP
Hialeah-Miami Lakes High School		7977 W 12th Avenue	Hialeah	33014		G	1,264	25,280		1,264		Per 2010 SESP;Bldg#'s required
Highland Oaks Middle School		2375 NE 203rd Street	N Miami Bea	33180		G	0	0		2,050		Per 2010 SESP;Bldg#'s required, in Cat 5 Zone
Hoover, Oliver Elementary		9050 Hammocks Blvd	Miami	33196		G	0	0		1,273		Per 2010 SESP;Bldg#'s required, possible Cat 5 zone
Jorge Mas Canosa Middle	2, 3	15735 SW 144 Street	Miami	33196	N	G	0	0		3,340		EHPA;Room#'s required, in Cat 4 Zone
Krop, Michael Senior High School		1410 NE County Line Road	N Miami Bea	33179		G,A	3,383	67,660		3,383		Per 2010 SESP;Bldg#'s required
Lake Stevens Elementary School		5101 NW 183rd Avenue	Miami	33055		G	1,018	20,360		1,018		Per 2010 SESP;Bldg#'s required
Lorah Park Elementary School		5160 NW 31st Avenue	Miami	33142		G	840	16,800		840		Per 2010 SESP;Bldg#'s required
Miami Carol City High School	1	3422 NW 187th Street	Miami	33056	R	G	3,795	75,899		2322		per master list
Miami -Dade Homeless Assistance center					R	G	1,000	20,000		1,000	L,S	Per 2010 SESP;Bldg#'s required
Miami Killian High School		10655 SW 97th Avenue	Miami	33176		G	420	8,400		420		Per 2010 SESP;Bldg#'s required
Miami Norland Senior High	18NewGyr	1050 NW 195th Street	Miami	33169	N	G	687	15,239		687	L	Updated F.I.S.H. Data
Miami Northwestern High School	1	7007 NW 13th Avenue	Miami	33150	R	G	2,420	48,400		2,420	S-1523-2002	Per 2010 SESP;Room#'s required

**2012 Statewide Emergency Shelter Plan**

**MIAMI-DADE**

Miami Palmetto Senior High		7460 SW 118th Street	Miami	33156		G	0	0		2,313		Per 2010 SESP;Bldg#'s required, in Cat 5/4 Zone
Miami Shores Elementary School		10351 NE 5th Avenue	Miami	33138		G	244	3,654		287		per master list
Miami Southridge Senior High	1	19355 SW 114th Street	Miami	33157	R	G	0	0		1,082		Per 2010 SESP;Room#'s required, in cat 3/4 zone
Miami Springs High	1	751 Dove Avenue	Miami Springs	33166	R	G	0	0		3,000	L, S - HMGP	Per 2010 SESP;Room#'s required, in cat 5/4 zone
Miami Sunset High	1 & 4	13125 SW 72nd Street	Miami	33183	R	G	0	0		2,440	S-1523-2002	Per 2010 SESP;Room#'s required, in possible cat 5 zone
Morgan, Robert Senior High	b18	18180 SW 122 Avenue	Miami	33177	N	G	546	10,913		1,000	L	Updated FISH Data
Morgan, Robert Senior High	b15	18180 SW 122 Avenue	Miami	33177		G	619	12,385			L	Per 2010 SESP;Room#'s required
Morgan, Robert Senior High	b16	18180 SW 122 Avenue	Miami	33177		G	557	11,136			L	Per 2010 SESP;Room#'s required
Morgan, Robert Senior High	b17-gym	18180 SW 122 Avenue	Miami	33177		G	867	17,332			L	Per 2010 SESP;Room#'s required
North Miami Beach High School	7	1247 NE 167th Street	N Miami Beach	33162	R	G	1,066	15,997		3,152		per master list
North Miami High School		13110 NE 8 Avenue	N Miami	33162	R	G	549	8,230		1,000		per master list
North Miami Middle School	campus	13105 NE 7th Avenue	N Miami Beach	33161	R	G	991	24,772		450	L, S	Per 2010 SESP;Room#'s required
Norwood Elementary School	4,6	19810 NW 14th Court	Miami	33169	R	G	368	5,519		895		Per 2010 SESP;Room#'s required
Olinda Elementary School	7	5536 NW 21st Avenue	Miami	33142	R	G	357	5,361		899		per master list
Orchard Villa Elementary School	1	5720 NW 13th Avenue	Miami	33142	R	G	1,067	16,011		1,179		per master list
Owens, Ruth Kruse Elementary School		11001 SW 76th Street	Miami	33173	R	G	0	0		741	L	:2010 SESP, 17.1' SLOSH
Palm Lakes Elementary School	5	7450 W 16th Avenue	Hialeah	33014	R	G	653	16,332		649		per master list
Palm Springs North Elementary School		17615 NW 82nd Avenue	Hialeah	33015	R	G	982	14,714		1,029		per master list
Pepper, Claude Elementary School		14550 SW 96th Street	Miami	33186	R	G	0	0		1,258		Per 2010 SESP;Bldg#'s required, in Cat 5 Zone
Pharr, Kelsey Elementary School	1.5	2000 NW 46th Street	Miami	33142	R	G	499	9,979		511		per master list
Porter, Gilbert Elementary School		15851 SW 112th Street	Miami	33196	R	G	0	0		1,769		Per 2010 SESP;Bldg#'s required, in Cat 5 Zone
Reagan, Ronald Senior High		8600 NW 107th Avenue	Doral	33178	N	G	2,943	58,868		2,943	L	EHPA;2010 SESP
Royal Green Elementary School		13047 SW 47th Street	Miami	33175	R	G	0	0		562	L	Per 2010 SESP;Bldg#'s required, in cat 5 Zone
Shenandoah Elementary School	b3	1023 SW 21st Avenue	Miami	33135	R	G	758	18,955		500	L	Updated FISH
Sheppard, Ben Elementary School	1 thru 10	5700 W 24th Avenue	Hialeah	33016	R	G	1,751	28,254		1,420		per master list
South Dade Senior High	campus	28401 SW 167th Avenue	Miami	33030	R	G	0	0		3,224	L, S-HMGP	s-1523-2002;updated FISH Data, in cat 4/5 Zone
South Dade Middle School	campus	29100 SW 194th Avenue	Miami	33030	N	G	0	0				Updated F.I.S.H. Data, in cat 4/5 zone
South Miami Senior High	campus	6858 SW 53rd Street	Miami	33155	N	G	0	0				Updated F.I.S.H. Data, in cat 4/5 zone
Southwood Middle School	1	16301 SW 80th Avenue	Miami	33157	R	G	0	0		1,500	L, S-HMGP	s-1523-2002;updated FISH Data, in cat 4 Zone
Stirrup Elementary School	1 thru 9	330 NW 97th Avenue	Miami	33172	R	G	839	20,938		775		Per 2010 SESP;Bldg#'s required
Sunshine Pavilion @ Tamiami Park		10901 SW 24th Street	Miami	33165	R	G,A	0	0		500		Per 2010 SESP;Bldg#'s required, in cat 4/5 zone
Terra Environmental Research Institut	Bldgs 3 & 4	11005 SW 84th Street	Miami	33173	N	G	0	0				in cat 4/5 Zone
Thomas, W. R. Middle School		13001 SW 26th Street	Miami	33175	R	G	0	0		2,050	S-1453	Per 2010 SESP;Bldg#'s required, in cat 4/5 zone
Van Blanton Elementary School	1,3	10327 NW 11th Avenue	Miami	n/a	R	G	1,248	24,960		1,150	L, S	per master list
Varela, Felix Senior High		15255 SW 96th Street	Miami	33197	N	G	0	0		2,913	L	EHPA;2010 SESP, possible in side cat 5 zone
Village Green Elementary School		12265 SW 34th Street	Miami	33175	R	G	0	0		565		Per 2010 SESP;Bldg#'s required, in cat 4/5 zone
Washington, Booker T. Senior High	b12a	1200 NW 6th Avenue	Miami	33136	N	G	1,067	21,334				Updated FISH
Washington, Booker T. Senior High	b13	1200 NW 6th Avenue	Miami	33136	N	G	428	8,560				Updated FISH
Washington, Booker T. Senior High	b14	1200 NW 6th Avenue	Miami	33136	N	G	0	0		0	L	see SpNS
<b>TOTALS FOR MIAMI-DADE COUNTY</b>							<b>61,455</b>	<b>1,279,118</b>	<b>0</b>	<b>91,035</b>		<b>0</b>

<b>Year 2012</b>	<b>Shelter Capacity In People</b>	<b>Shelter Demand In People</b>	<b>Surplus/ Deficit In People</b>	<b>Shelter Capacity (ft2)</b>		<b>Surplus/ Deficit (ft2)</b>	<b>Result</b>
Storm Category 4/5	61,455	59,177	2,278	#####		95,578	

**Special Needs Storm Shelters**

Name	Bldg #	Address	City	Zip			SpNS Capacity (spaces @ 60sf) (meets ARC 4496)	SpNs Capacity (sf) (meets ARC 4496)	SpNS Capacity (spaces @ 60sf) (does not meet ARC 4496)	Local Planned usages	Comments
HD McMillian (2nd Tier)		13100 SW 59 street	Miami	33183	R	P	0	0		500	Per 2010 SESP;Bldg#'s required, in cat 4/5 zone
Jose Marti MS (2nd Tier)	Campus	5701 W 24th Avenue	Hialeah	33016	R	P	578	43,322		500	per master list
Miami Jackson Snr HS		1751 NW 36th Street	Miami	33142	R	P	565	33,900		565	Per 2010 SESP;Bldg#'s required
Miami Edison HS (1st Tier)		6161 NW 5th Court	Miami	33127	R	P	500	30,000		500	Per 2010 SESP;Bldg#'s required

**2012 Statewide Emergency Shelter Plan**

**MIAMI-DADE**

Washington, Booker T. Senior High	b14	1200 NW 6th Avenue	Miami	33136	N	P	1,028	23,830		1,028	L	:Updated F.I.S.H. Data
Rubin Dario MS (1st Tier)	1,2	350 NW 97th Avenue	Miami	33172	R	P	637	47,731		500		per master list
John Ferguson Senior	3, 4	29100 SW 194 Ave	Homestead	33157	R	P	0	0		1,704		EHPA;Updated FISH Bldg#'s 3&4, in cat 5 zone
<b>Year 2012</b>	<b>SpNs Shelter Capacity In Spaces (meets ARC 4496)</b>	<b>SpNs Shelter Demand In Spaces</b>	<b>Surplus/ Deficit In Spaces</b>	<b>SpNs Shelter Capacity (ft2)</b>			<b>Surplus/ Deficit (ft2)</b>	<b>Result</b>				
Storm Category 4/5	3,308	2,717	591	198,480			35,460					

**2012 Statewide Emergency Shelter Plan**

<b>MONROE</b>												
Name	Bldg. #	Address	City	Zip	Retrofitted (R) or New Construction (N)	General (G), PSN (P), Pet-Friendly (A)	Total Risk Capacity In People <small>(Meets ARC 4496)</small>	Total Risk Capacity (ft <sup>2</sup> ) <small>(Meets ARC 4496)</small>	Risk Capacity In People <small>(Does not Meet ARC 4496 or Not Yet Surveyed)</small>	Local Planned Usage (reported capacity)	Funding Source: Local (L), State (S), Federal (F), and Program Name	Comments
Coral Shores	Café	89901 Old Hwy	Islamorada	33070	R	G,A		0	0	237	L	surge issues, in cat 4 zone
Florida Intl' Univ (Univ Park Campus)	PC(Primera Casa/ CE Perry	11200 SW 8th Street	Miami	33165	R	G		0	0	1,289		Gen Pop Only
Florida Intl' Univ (Univ Park Campus)	40 - Recreation Center (1st floor only)	11200 SW 8th Street	Miami	33199	N	G	602	10,220		602		Gen Pop Only
Key Largo School	Café	104801 Overseas Hwy	Key Largo	33070	R	G	0	0	0			in cat 3/4 zone
Key West HS	Café	2100 Flager Ave	Key West	33040		G,A	0	0	0	354	L	surge issues, in cat 2/3 zone
Marathon Hs	Café	350 Sombrero Road	Marathon	33050		G	0	0	0			in cat 2 zone
Poinciana ES	CAFÉ, Admin.Music and Arts		Key West			G	0	0	0		L	surge issues, in cat 2/3 zone
	0 Parish Hall	105500 Overseas Hwy	Key largo			G	0	0	0	250		In cat 3 zone
Stanley Switlik ES	Café-bldg 2	3400 overseas Hwy	Marathon	33050		G	0	0	0	280	L	surge issues, in cat 2 zone
Sugarloaf	16	RT 2 CRANE RD	Sugarloaf key	33042	N	G,A	0	0	0		COPS	surge issues, in cat 2,3,4 zone
Sugarloaf MS	café	255 Crane Rd	Sugarloaf key	33042		G	0	0	0	352	COPS	surge issues, in cat 2,3,4 zone
<b>TOTALS FOR MONROE COUNTY</b>							<b>602</b>	<b>10,220</b>	<b>0</b>	<b>3,364</b>		<b>0</b>
<b>Year 2012</b>	<b>Shelter Capacity In People</b>	<b>Shelter Demand In People</b>	<b>Surplus/Deficit In People</b>	<b>Shelter Capacity (ft2)</b>			<b>Surplus/Deficit (ft2)</b>	<b>Result</b>				
Storm Category 4/5	602	2,771	-2,169	10,220			-45,200					
<b>Special Needs Storm Shelters</b>												
Name	Bldg #	Address	City	Zip			SpNS Capacity (spaces @ 60sf) (meets ARC 4496)	SpNs Capacity (sf) (meets ARC 4496)	SpNS Capacity (spaces @ 60sf) (does not meet ARC 4496)	Local Planned Usage (reported capacity)	Funding Source: Local (L), State (S), Federal (F), and Program Name	Comments
FIU	40 - Recreation Center (2nd floor only)	11200 SW 8th Street	Miami	33199	N	P	121	5,443		91		1st Flr G+10220 SF, 2nd Flr P=5443- Note Shelter dual use (G & P)
								0				
								0				
								0				
								0				
<b>Year 2012</b>	<b>SpNs Shelter Capacity In Spaces (meets ARC 4496)</b>	<b>SpNs Shelter Demand In Spaces</b>	<b>Surplus/Deficit In Spaces</b>	<b>SpNs Shelter Capacity (ft2)</b>			<b>Surplus/Deficit (ft2)</b>	<b>Result</b>				
Storm Category 4/5	121	91	30	7,260			1,800					

**2012 Statewide Emergency Shelter Plan**

**NASSAU**

Name	Bldg. #	Address	City	Zip	Retrofitted (R) or New Construction (N)	General (G), PSN (P), Pet-Friendly (A)	Total Risk Capacity In People (Meets ARC 4496)	Total Risk Capacity (ft <sup>2</sup> ) (Meets ARC 4496)	Risk Capacity In People (Does not Meet ARC 4496 or Not Yet Surveyed)	Local Planned Usage (reported capacity)	Funding Source: Local (L), State (S), Federal (F), and Program Name	Comments
Bryceville Elementary School	8	6504 Church Rd	Bryceville	32009	N	G	128	2,550		64		operation 2008-2009
Callahan Elementary School	6	449618 US Hwy 301	Callahan	32011		G	0	0		326		
Callahan Intermediate School	1	34586 Ball Park Rd	Callahan	32011	R	G	0	6,537	327	326	L	
Callahan Middle School	15	450121 Old Dixie Hwy	Callahan	32011	N	G,A	528	7,925		311		per master list
Hilliard Middle School	15	1 Flashes Ave	Hilliard	32046	N	P	0	0		105	L	Spns see below.
Hilliard Elementary School	1	275568 Ohio St	Hilliard	32046	R	G	326	5,618		326	L	per master list
West Nassau High School	6	1 Warrior Drive	Callahan	32011	N	G	561	8,579		280	L	per master list
Yulee Elementary School	9	86063 Felmore Rd	Yulee	32097	N	G,A	370	5,867		185		per master list
Yulee High School	4,6,8	85375 Miner Rd	Yulee	32097	N	G	1,373	34,325		965	L	per master list
Yulee Middle School *	3,4,5,6	85439 Miner Rd	Yulee	32097	N	G	965	19,302		965	L	per master list
Yulee Primary School	7	86426 Goodbread Rd	Yulee	32097		G	0	0	220	129		2.4' SLOSH
<b>TOTALS FOR NASSAU COUNTY</b>							<b>4,251</b>	<b>90,703</b>	<b>547</b>	<b>3,982</b>		<b>0</b>
<b>Year 2012</b>	<b>Shelter Capacity In People</b>	<b>Shelter Demand In People</b>	<b>Surplus/ Deficit In People</b>	<b>Shelter Capacity (ft2)</b>			<b>Surplus/ Deficit (ft2)</b>	<b>Result</b>				
Storm Category 4/5	4,251	4,018	233	90,703			10,343					
<b>Special Needs Storm Shelters</b>												
Name	Bldg #	Address	City	Zip			SpNS Capacity (spaces @ 60sf) (meets ARC 4496)	SpNs Capacity (sf) (meets ARC 4496)	SpNS Capacity (spaces @ 60sf) (does not meet ARC 4496)	Local Planned usage	Funding Source: Local (L), State (S), Federal (F), and Program Name	
Hilliard Middle School	15	1 Flashes Ave	Hilliard	32046	N	P	156	8,838		105	L	
<b>Year 2012</b>	<b>SpNs Shelter Capacity In Spaces (meets ARC 4496)</b>	<b>SpNs Shelter Demand In Spaces</b>	<b>Surplus/ Deficit In Spaces</b>	<b>SpNs Shelter Capacity (ft2)</b>			<b>Surplus/ Deficit (ft2)</b>	<b>Result</b>				
Storm Category 4/5	156	185	-29	9,360			-1,740					

**2012 Statewide Emergency Shelter Plan  
OKALOOSA**

Name	Bldg. #	Address	City	Zip	Retrofitted (R) or New Construction (N)	General (G), PSN (P), Pet - Friendly (A)	Total Risk Capacity In People (Meets ARC 4496)	Total Risk Capacity (ft <sup>2</sup> ) (Meets ARC 4496)	Risk Capacity In People (Does not Meet ARC 4496 or Not Yet Surveyed)	Local Planned Usage (reported capacity)	Funding Source: Local (L), State (S), Federal (F), and Program Name	Comments
Antioch Elementary School	1	4700 Whitehurst Lane	Crestview	32536	R	G	1,303	21,396	0	1,737	S-1467-2004	
Baker High School	B18	1369 14th Street	Baker	32531		G	166	2,495		266		
Choctawhatchee HS	1E	110 racetrack Rd NW	Fort Walton Beach	32547	R	G	370	5,547		435	L	
Davidson Middle School	Building 1- except spns wing-café)	6261 Old Bethel Rd.	Crestview	32536	(R)	G	3,267	49,356		3,267	(S)	
NWF Raider Stadium	Building T	11 E. College Blvd	Niceville	32578	(N)	G,A	2,025	40,500		2,700	(S)	2011
Kenwood ES	10	634 Eagle St	Fort Walton Beach	32547	R	G	399	5,989		467	L	shuttered per county
Riverside ES	Wing C-200	3400 Redstone Avenue	Crestview	32539	N	G	360	5,396		360		per FDEM report
Riverside ES	Wing D-300	3400 Redstone Avenue	Crestview	32539	N	G	360	5,396		360		per FDEM report
	Wing E-400	3400 Redstone Avenue	Crestview	32539	N	G	360	5,396		360		per FDEM report
Riverside ES	Wing F-500	3400 Redstone Avenue	Crestview	32539	N	G	397	5,955		397		per FDEM report
Riverside ES	Wing G-600	3400 Redstone Avenue	Crestview	32539	N	G	457	6,856		457		per FDEM report
Riverside ES	Wings A-B	3400 Redstone Avenue	Crestview	32539	N	G	677	10,151		677		per FDEM report
Shoal river MS	Main Bldg	3200 Redstone Avenue	Crestview	32539	N	G	1,240	18,595		1,240		per FDEM report
Shoal river MS	Wing A-Gym	3200 Redstone Avenue	Crestview	32539	N	G	838	12,568		838		per FDEM report
Shoal river MS	Wing B- 6th grade	3200 Redstone Avenue	Crestview	32539	N	G	541	8,118		541		per FDEM report
Shoal river MS	Wing C-7th grade	3200 Redstone Avenue	Crestview	32539	N	G	492	7,386		492		per FDEM report
Shoal river MS	Wing D- 8th grade	3200 Redstone Avenue	Crestview	32539	N	G	542	8,131		542		per FDEM report
<b>TOTALS FOR OKALOOSA COUNTY</b>							<b>13,794</b>	<b>219,231</b>	<b>0</b>	<b>15,136</b>		

Year 2012	Shelter Capacity In People	Shelter Demand In People	Surplus/ Deficit In People	Shelter Capacity (ft2)		Surplus/ Deficit (ft2)	Result
Storm Category 4/5	13,794	5,622	8,172	219,231		106,791	

**Special Needs Storm Shelters**

Name	Bldg #	Address	City	Zip			SpNS Capacity (spaces @ 60sf) (meets ARC 4496)	SpNs Capacity (sf) (meets ARC 4496)	SpNS Capacity (spaces @ 60sf) (does not meet ARC 4496)	local planned usage	Funding Source: Local (L), State (S), Federal (F), and Program Name	Comments
Davidson MS (spns wing-cafe)		6261 Old Bethel Rd	Crestview	32536	R	P	70	4,200		70		
Project (TBD)		TBD	TBD					0				

Year 2012	SpNs Shelter Capacity In Spaces (meets ARC 4496)	SpNs Shelter Demand In Spaces	Surplus/ Deficit In Spaces	SpNs Shelter Capacity (ft2)		Surplus/ Deficit (ft2)	Result
Storm Category 4/5	70	415	-345	4,200		-20,700	

**2012 Statewide Emergency Shelter Plan**

**OKEECHOBEE**

Name	Bldg. #	Address	City	Zip	Retrofitted (R) or New Construction (N)	General (G), PSN (P), Pet-Friendly (A)	Total Risk Capacity In People (Meets ARC 4496)	Total Risk Capacity (ft <sup>2</sup> ) (Meets ARC 4496 or Not Yet Surveyed)	Risk Capacity In People (Does not Meet ARC 4496 or Not Yet Surveyed)	Local Planned Usage (reported capacity)	Funding Source: Local (L), State (S), Federal (F), and Program Name	Comments
American Legion Post #64		501 SE 2nd Street	Okeechobee	34972			0	0	200			
Everglades Elementary School		3725 SE 8th Street	Okeechobee	34972			0	0	222			
First Baptist Church	Fam Life	401 SW 4th Stree	Okeechobee	34972	N	G	0	0	507	507	L	
Freshman Center Auditorium	N	610 SW 2nd Ave	Okeechobee	34972	R	G	0	0	332	332		
Ft. Drum Community Church		32415 Highway 441 North	Okeechobee	34972			0	0	120			
Moose Lodge		159 NW 36th Street	Okeechobee	34972			0	0	133			
North Elementary School		3000 NW 10th Terrace	Okeechobee	34972			0	0	500			
Okeechobee High School		2800 Highway 441 North	Okeechobee	34972			0	0	1,049			
Osceola Middle School	3	825 SW 21st Street	Okeechobee	34972	R	G	121	2,423		298	HMGP	Interior corridor only
Osceola Middle School	6	825 SW 21st Street	Okeechobee	34972	R	G	50	1,018		297	HMGP	Interior corridor only
Osceola Middle School	7	825 SW 21st Street	Okeechobee	34972	R	G	140	2,816		298	HMGP	Interior corridor only
Presbyterian Church		312 N Parrot Avenue	Okeechobee	34972			0	0	133			
Public Health Center		1728 NW 9th Avenue	Okeechobee	34972			0	0				
Sacred Heart Catholic Church		701 SW 6th Street	Okeechobee	34972			0	0	667			
Seminole Elementary School		2690 NW 42nd Avenue	Okeechobee	34972			0	0	222			
South Elementary School	1	575 SW 28th Street	Okeechobee	34972	N	G	1,011	20,215		1,011	L, S	
Yearling Middle School		925 NW 23rd Lane	Okeechobee	34972	R	G	500	10,000		500	HMGP	
<b>TOTALS FOR OKEECHOBEE COUNTY</b>							<b>1,822</b>	<b>36,472</b>	<b>4,585</b>	<b>3,243</b>		<b>0</b>
<b>Year 2012</b>	<b>Shelter Capacity In People</b>	<b>Shelter Demand In People</b>	<b>Surplus/ Deficit In People</b>	<b>Shelter Capacity (ft2)</b>			<b>Surplus/ Deficit (ft2)</b>					
Storm Category 4/5	1,822	5,295	-3,473	36,472			-69,428					
<b>Special Needs Storm Shelters</b>												
Name	Bldg #	Address	City	Zip			SpNS Capacity (spaces @ 60sf) (meets ARC 4496)	SpNs Capacity (sf) (meets ARC 4496)	SpNS Capacity (spaces @ 60sf) (does not meet ARC 4496)	Local Planned Usage (reported capacity)	Funding Source: Local (L), State (S), Federal (F), and Program Name	Comments
TBD												
Okeechobee CHD		1728 NW 9th Avenue	Okeechobee	34972		P	0	0		66		needs ASCE-7 cert.
<b>Year 2012</b>	<b>SpNs Shelter Capacity In Spaces (meets ARC 4496)</b>	<b>SpNs Shelter Demand In Spaces</b>	<b>Surplus/ Deficit In Spaces</b>	<b>SpNs Shelter Capacity (ft2)</b>			<b>Surplus/ Deficit (ft2)</b>	<b>Result</b>				
Storm Category 4/5	0	1,271	-1,271	0			-76,260					

2012 Statewide Emergency Shelter Plan

ORANGE

Name	Bldg. #	Address	City	Zip	Retr ofitt ed (R) or New	General (G), PSN (P), Pet - Friendly (A)	Total Risk Capacity In People (Meets ARC 4496)	Total Risk Capacity (ft <sup>2</sup> ) (Meets ARC 4496)	Risk Capacity In People (Does not Meet ARC 4496 or Not Yet Surveyed)	Local Planned Usage (reported capacity)	Funding Source: Local (L), State (S), Federal (F), and Program Name	Comments
Apopka High School	306/Gym (FISH bldg 23)	555 Martin Street	Apopka	32712	N	G	759	12,895		759		
Apopka High School	701/Cafeteria	555 Martin Street	Apopka	32712	N	G	0	0		606	L	
Apopka Middle School	831/Café (Fish bldg 15)	425 N Park Avenue	Apopka	N/A			0	0	204			building under renovation
Audubon Park ES	1-117 Café	1750 Common Way RD	Orlando	32814		G	310	6,194		310		
Avalon MS	401 Café	13914 Mailer Blvd	Orlando	32828	N	G	591	8,872		598		per FDEM study
Avalon MS	Bldg 3-Gym	13914 Mailer Blvd	Orlando	32828	N	G	615	12,295				per FDEM study
Barnett Park Community Center		4801 W Colonial Drive	Orlando	N/A		G,A	0	0				
Bithlo Community Center Bldg		18501 Washington Avenue	Orlando	N/A		G,A	0	0				
Blankner School (Priority 4)	Bldg 2-Gym	2500 South Mills Ave	Orlando	32806	N	G	605	12,110				per master list
Boone HS	800 gym	2000 S. Mills Avenue	Orlando	32806			0	0	560	560		
Boone HS	801 Café	2000 S. Mills Avenue	Orlando	32806			0	0	454	454		
Bridgewater MS	300 Gym	5660 Tiny Road	Winter Garden	34787			552	12,251		552	L	per FDEM study
Bridgewater MS	401A-Café&MP	5660 Tiny Road	Winter Garden	34787			550	8,954		550	L	per FDEM study
Carver Middle School	307 Café	4500 West Columbia Street	Orlando	32811			0	0	191	191		
Chain of Lakes Middle School	701 Café	8720 Conroy Windemere Rd	Orlando	32835	R	G	0	0	538	538		per county 6-15/09
Colonial 9th Grade School	200 Café/MP	7775 Valencia College Lane	Orlando	32807			0	0	427	427		
Colonial 9th Grade School	801-Gym only	7775 Valencia College Lane	Orlando	32807	N	G	473	11,590		473	L	per FDEM study
Colonial HS	5-110 Gym	6100 Oleander Dr	Orlando	32807			0	0	310	310		
Colonial HS	6-145 Café	6100 Oleander Dr	Orlando	32807			0	0	474	474	L	per county 8-23-05
Conway Middle School	bldg 3- rm144 Café	4600 Anderson Road	Orlando	32812		G	195	3,901		195	L	2008-2009 per County
Corner Lake Middle School	bldg 8, Rm101 Café/MP	1700 Chuluota Road	Bithlo	32820			0	0	346	346		
Cypress Creek High School	bldg C-107-gym	1101 Bear Crossing	Orlando	32824	R	G	0	0	1,008	1,008		per FDEM study?
Cypress Creek High School	bldg D-108-cafeteria	1101 Bear Crossing	Orlando	32824	R	G	0	0	615	615		per FDEM study?
Discovery Middle School	Bldg 8-RM101 - Café/MP	601 Woodbury Road	Orlando	32828			0	0	489	489		need shutters
Dr. Phillips 9th Grade	21 Café	6500 Turkey Lake Road	Orlando	32819	R	G	304	6,070		304		
Dr. Phillips High School	501-cafeteria	6500 Turkey Lake Road	Orlando	32819	R	G	492	9,840		492	L	
Dr. Phillips High School	610-gym	6500 Turkey Lake Road	Orlando	32819	R	G	710	14,190		710		
East River High School	306 Gym	654 Columbia School Rd	Orlando	32833	N	G	0	0		0		see SpNS
East River High School	701 Café	654 Columbia School Rd	Orlando	32833	N	G	0	0		0		see SpNS
Edgewater High School	600 gym	3100 Edgewater Drive	Orlando	32804			566	11,320	566	566		per master list
Edgewater High School	Bldg 8 Café	3100 Edgewater Drive	Orlando	32804			384	7,680	384	384		per master list
Evans High School	521 Gym	4949 Silver Star Road	Orlando	32808			468	9,360	468			
Evans High School	602/603 Café	4949 Silver Star Road	Orlando	32808			452	9,040	452			
Fort Gatlin Recreation Center		2009 Lake Margaret Drive	Orlando	N/A		G,A	0	0		100	F,S	
Freedom High School	Bldg 6-		Orlando			G	58	1,162				
Freedom High School	Bldg 5-		Orlando			G	164	3,284				
Freedom Middle	bldg 3-301 - Gym	2850 TAFT VINELAND ROAD	Orlando	32837		G	556	11,998		556		per FDEM study
Freedom Middle	401 - Dining Area	2850 TAFT VINELAND ROAD	Orlando	32837		G	368	9,029		368		per FDEM study
Freedom Middle	401A - Mult. Rm- Dining Area	2850 TAFT VINELAND ROAD	Orlando	32837		G	226	4,515		226		per FDEM study
Glenridge Middle School	4-gym	801 Glenridge Way	Winter Park	32789	N	G	660	13,204				per FDEM study
Glenridge Middle School	5-Cafeteria	801 Glenridge Way	Winter Park	32789	N	G	188	3,751				per FDEM study
Gotha Middle School	7-Gym	9155 Gotha Road	Windemere	34787			0	0	605	605		need shutters
Gotha Middle School	Bldg 8 RM101 Café/MP	9155 Gotha Road	Windemere	34787			0	0	255	255		need shutters
Howard Middle School	rm144 Café	800 E Robinson St.	Orlando	32801			0	0	317	317		
Hunters Creek Middle School	Bldg 8 RM101 Café/MP	13400 Town Loop Blvd.	Orlando	32837			0	0	322	322		need shutters
Jackson Middle School	Bldg 8- 801-Café only	6000 Stonewall Jackson	Orlando	32807	N	G	407	9,709		407		2007-2008 per County
John Bridges Community Center		445 West 13th Street	Apopka	N/A		G	0	0		206		
Jones High School	Bldg 3 RM115 Café	1400 W. Cypress Dr	Orlando	32805			0	0	336	336		circa 2003-per county 8-23-05
Jones High School	Bldg 6 RM112 Gym	1400 W. Cypress Dr	Orlando	32805			0	0	434	434		circa 2003-per county 8-23-05
Lake Nona High School	306 Gym	12500 Narcoossee Rd	Orlando	32832			759	18,999		759		per FDEM study
Lake Nona High School	701 Café	12500 Narcoossee Rd	Orlando	32832			605	9,158		605		per FDEM study
Lakeview Middle - Org	Bldg 9-100 Café	1200 West Bay Street	Winter Garden	34787	N	G	0	0		312		Bldg 9? - Ehpa?-per county 8-23-05
Lakeview Middle - Org	Bldg 2- gym	1200 West Bay Street	Winter Garden	34787			604	12,083				per FDEM study
Lee Middle School	Bldg 2- 800 Café	1201 Maury Road	Orlando	32804			0	0		382		not hardened





**2012 Statewide Emergency Shelter Plan**

**ORANGE**

Blankner School (Priority 4)	Bldg 2-201 Café	2500 South Mills Ave	Orlando	32806	N	P	151	12,110		134		PBSJ report- 120mph-threshold bldg
Freedom HS (priority 3)	7-701-Café	2500 Taft-Vineland Rd	Orlando	32837	N	P	134	7,679		134		per FDEM study
Freedom HS (priority 3)	3-306 gym	2500 Taft-Vineland Rd	Orlando	32837	N	P	222	17,562		134		per FDEM study
Olympia High School	Bldg 3-306 Gym	4301 S. Apopka-Vineland	Orlando	32835	N	P	251	19,188		251	per County 8-23-05	no exterior walls
Olympia HS (Priority 2)	7-cafeteria	4301 S. Apopka-Vineland	Orlando	32835	N	P	197	8,395		197		
East River High School	306 Gym	654 Columbia School Rd	Orlando	32833	N	P	316	18,999		759		per master list
East River High School	701 Café	654 Columbia School Rd	Orlando	32833	N	P	131	7,875		605		per master list
							0	0				
							0	0				
							0	0				
							0	0				
<b>Year 2012</b>	<b>SpNs Shelter Capacity In Spaces (meets ARC 4496)</b>	<b>SpNs Shelter Demand In Spaces</b>	<b>Surplus/ Deficit In Spaces</b>	<b>SpNs Shelter Capacity (ft2)</b>			<b>Surplus/ Deficit (ft2)</b>	<b>Result</b>				
Storm Category 4/5	1,402	220	1,182	84,120			70,920					

2012 Statewide Emergency Shelter Plan

OSCEOLA

Name	Bldg. #	Address	City	Zip	Retrofit ed (R) or New Constru ction (N)	General (G), PSN (P), Pet - Friendl y (A)	Total Risk Capacity In People (Meets ARC 4496)	Total Risk Capacity (ft <sup>2</sup> ) (Meets ARC 4496 or Not Yet Surveyed) <sup>1</sup>	Risk Capacity In People (Does not Meet ARC 4496 or Not Yet Surveyed)	Local Planned Usage (Repor ed Capacity)	Funding Source: Local (L), State (S), Federal (F), and Program Name	Comments
Bella Lago	Gym	3651 Pleasant Hill Rd	Kissimmee	34741	N	G	400	8,000		400	L	
Boggy Creek Elementary School		810 Florida Parkway	Kissimmee	34741		G	0	0				
Celebration HS	5	1809 Celebration	Kissimmee	34741	R	G	732	14,640			HB7121	
Celebration HS	7	1809 Celebration Blvd	Kissimmee	34747	R	G	1,196	23,920			S-1496-2009	
Celebration HS	8	1809 Celebration Blvd	Kissimmee	34747	R	G	375	7,500			S-1496-2009	
Celebration HS	2-gym	1809 Celebration Blvd	Kissimmee	34747	R	G	822	17,619		822	S-1508-2005	
Chestnut ES	Cafeteria	4300 Chestnut St.	Kissimmee	34759	N	G	551	11,020		551	L	
Cypress Elementary School		2251 Lakeside Drive	Kissimmee	34744		G	0	0				
Deerwood Elementary School		3701 Lakeside Drive	Kissimmee	34758		G	0	0				
Denn John Middle School		2001 Denn John Lane	Kissimmee	34744		G	0	0				
Discovery Intermediate	Cafeteria/gym	5350 San Miggel	Poinciana	34759	R	G	908	14,316		908	S-1508-2005	
Discovery Intermediate School Bldg 1	1	5350 San Miguel	Kissimmee	34758	R	G	127	2,540			HB7121	
Discovery Intermediate School Bldg 3	3	5350 San Miguel	Kissimmee	34758	R	G	191	3,900			HB7121	
Discovery IS	4	5350 San Miguel	Kissimmee	34758	R	G	235	4,700			S-1496-2009	
Discovery IS	5	5350 San Miguel	Kissimmee	34758	R	G	556	4,700			S-1496-2009	
Elementary N	1	4001 Boggy Creek Rd	Kissimmee	34744	N	G	4,505	90,100			L	
Floral Ridge ES	Café	2900 Dyer Ave	Kissimmee	34741	N	G	301	6,027		301	L	
Florida Christian College	Gym	1011 Bill Beck Blvd	Kissimmee	34744	R	G	709	14,180			S-1508-2005	
Gateway High School	Gym/Auditorium	801 Bill Beck Boulevard	Kissimmee	34744		G	0	0				
Harmony ES	cafeteria	3365 Schoolhouse	St. Cloud	34773	N	G	388	7,777		388	L	
Harmony HS	4	3602 ARTHUR J. GALLAGHER BOULEVARD	St. Cloud	34772	R	G	722	14,440			S-1496-2009	
Harmony HS	5	3601 Arthur Gall.	St. Cloud	34771	R	G	711	14,220			HB7121	
Harmony HS	7	3601 Arthur Gall.	St. Cloud	34771	R	G	1,805	36,100			HB7121	
Harmony HS	8	3602 Arthur Gall.	St. Cloud	34772	R	G	376	7,520			S-1496-2009	
Harmony HS	2-Gym	3601 ARTHUR J. GALLAGHER BOULEVARD	St. Cloud	34771	R	G,A	932	19,764		932	S-1508-2005	
Horizon Middle School	2-gym	2020 Ham Brown Road	Kissimmee	34746	R	G	1,003	20,069		1,003	S-1118A	
Kenansville Comm Center	Center	1178 Old Canoe Creek	St. Cloud	34769	R	G	120	2,400		120	S-1508-2005	
Kissimmee Elementary School Bldg 5	5	3700 Donegan	Kissimmee	34741	R	G	176	3,520			HB7121	
Kissimmee Elementary School Bldg 6	6	3700 Donegan	Kissimmee	34741	R	G	183	3,660			HB7121	
Kissimmee ES	4-café	2420 Dyer Boulevard	Kissimmee	3474	R	G	209	5,010		301	S-1508-2005	
Kissimmee Middle School	2-gym	2410 Dyer Boulevard	Kissimmee	34741	R	G,A	875	17,496		936	S-1118A	
KOA Elementary School	1	500 Koa St	Kissimmee	34758	N	G	231	4,620		231	L	
Liberty HS	5-gym	4250 Pleasant Hill	Kissimmee	34746	N	G,A	1,335	26,698		892	L	
Michigan Avenue Elementary School		2015 S Michigan Avenue	St. Cloud	34769			0	0				
Mill Creek Elementary School		1700 Mill Slough Road	Kissimmee	34744			0	0				
Narcoossee Comm School	2-gym/café				R	G	891	14,200		891	S-1508-2005	
Narcoossee Comm School	3	2700 Narcoossee Rd	Kissimmee	34771	R	G	497	9,940			HB7121	
Narcoossee Comm School	4	2700 Narcoossee Rd	Kissimmee	34771	R	G	199	3,980				
Narcoossee Elementary School	cafeteria	2690 Narcoossee Rd	Kissimmee	34771	N	G	2,158	43,171		388	L	
Neptun ES	1-cafeteria	5901 Neptune Rd.	St. Cloud	34769	N	G	310	6,207		310	L	
Neptune MS		2727 Neptune Rd	Kissimmee	34744			0	0				
Oak Leaf Landing		2350 N. Central Avenue	Kissimmee		R	G	0	0		0	S-1588-2006	
Parkway Middle School		857 Florida Parkway	Kissimmee	34743			0	0				
Partin Settlement ES	1-Cafeter	2434 Remington Blvd	Kissimmee	34744	N	G	436	8,720		436		
Poinciana ES	2	4200 Rhododendron	Kissimmee	34758	R	G	183	3,660			S-1496-2009	
Poinciana ES	3	4200 Rhododendron	Kissimmee	34758	R	G	152	3,040			HB7121	
Poinciana ES	4	4200 Rhododendron	Kissimmee	34758	R	G	301	4,834		301	S-1508-2005	
Poinciana ES	5	4200 Rhododendron	Kissimmee	34758	R	G	176	3,520			HB7121	
Poinciana ES	6	4200 Rhododendron	Kissimmee	34758	R	G	183	3,660			HB7121	
Reedy Creek Elementary School	Bldg 1	2300 Brook Court	Kissimmee	34758	R	G	1,410	28,200		1,410	S-1118A	

**2012 Statewide Emergency Shelter Plan**

**OSCEOLA**

Reedy Creek Elementary School (two story add)	Bldg 2	2300 Brook Court	Kissimmee	34758	R	G	936	18,720		936	S-1467-2004	
School for the Arts	Auditorium	3151 N. Orange Blossom Trail	Kissimmee	34744		G	0	0				
St. Cloud ES	1-Caferia	2701 Budinger Ave	St. Cloud	34769	N	G	551	11,020		551	L	
St. Cloud Middle School		1975 S Michigan Avenue	St. Cloud	34769		G	0	0				
Sunrise ES		1925 Ham Brown Rd	Kissimmee	34746	N	G	551	11,020		551	L	
Thacker Elementary School		301 Thacker Avenue	Kissimmee	34741		G	0	0				
Ventura Elementary School	3	275 Water Edge Drive	Kissimmee	34743	R	G	436	8,720		436	S-1588-2006	
Westside K-8 School	Gym	2551 Westside Blvd	Kissimmee	34747 N		G	495	9,900				
							0	0				
<b>TOTALS FOR OSCEOLA COUNTY</b>							<b>30,539</b>	<b>598,968</b>	<b>0</b>	<b>13,995</b>		<b>0</b>

<b>Year 2012</b>	<b>Shelter Capacity In People</b>	<b>Shelter Demand In People</b>	<b>Surplus/ Deficit In People</b>	<b>Shelter Capacity (ft2)</b>			<b>Surplus/ Deficit (ft2)</b>	<b>Result</b>				
Storm Category 4/5	30,539	7,309	23,230	598,968			452,788					

**Special Needs Storm Shelters**

Name	Bldg #	Address	City	Zip			SpNS Capacity (spaces @ 60sf) (meets ARC 4496)	SpNs Capacity (sf) (meets ARC 4496)	SpNS Capacity (spaces @ 60sf) (does not meet ARC 4496)	local planned usage	Funding Source: Local (L), State (S), Federal (F), and Program Name	Comments
Central Ave ES	Cafeteria	1502 N Central Avenue	Kissimmee	34741	N	P	550	33,050		500		
Barney E. Veal Center	A	700 Generations Point	Kissimmee	34744	N	P	285	17,100		285		
St. Cloud Senior Center		3101 17th Street	St. Cloud	34769	R	P	166	9,960		166	S-1543A	
Oak Leaf Landing		2350 N. Central Avenue	Kissimmee	34741	R	P	330	19,800		251	S-1588-2007	per PBSJ report
<b>Year 2012</b>	<b>SpNs Shelter Capacity In Spaces (meets ARC 4496)</b>	<b>SpNs Shelter Demand In Spaces</b>	<b>Surplus/ Deficit In Spaces</b>	<b>SpNs Shelter Capacity (ft2)</b>			<b>Surplus/ Deficit (ft2)</b>	<b>Result</b>				
Storm Category 4/5 updated 5/20/09	1,331	37	1,294	79,860			77,640					

**2012 Statewide Emergency Shelter Plan**

**PALM BEACH**

Name	Bldg. #	Address	City	Zip	Retrofit ed (R) or New Constru ction (N)	General (G), PSN (P), Pet - Friendly (A)	Total Risk Capacity In People (Meets ARC 4496)	Total Risk Capacity (ft <sup>2</sup> ) (Meets ARC 4496)	Risk Capacity In People (Does not Meet ARC 4496 or Not Yet Surveyed)	Local Planned Usage (reported capacity)	Comments
Atlantic Community HS	2,3,4,5,6,7	2455 W. atlantic Ave	Delray	33445	N	G	5,040	75,604		5,750	Hurricane Risk Shelter
Bear Lakes Middle School	1,2,3,4, G	3505 Shenandoa Boulevard	W Palm Beach	33409	R	G	1,428	21,422			Secondary Shelter
Boca Raton Community HS	2,3,4,5,6	1501 NW 15th Ct	Boca Raton	33486	N	G	3,900	62,759		3,900	Hurricane Risk Shelter
Boca Raton Community Church		407 NW 4th Ave	Boca Raton	33432		G	0	0			Host Shelter
Boynton Beach High School	1,3,6	4975 Park Ridge Boulevard	Boynton Beach	33462	N	G	2,720	49,044		2,720	Hurricane Risk Shelter
Carver Middle School	2,4,6,8	101 Barwick Road	Delray Beach	33445	R	G	1,460	23,246			Secondary Shelter
Chapel of St. Andrews Episcopal Church		2707 NW 37th Street	Boca Raton	33434		G	0	0			Host Shelter
Christa McCauliffe Middle School	1,2,3,4	6500 Le Chalet Boulevard	Boynton Beach	33437	R	G	1,600	25,840		0	Secondary Shelter
Church of Latter Day Saints		1710 Cardantis Road	West Palm Beach	33406		G	0	0			Host Shelter
Community United Methodist Church		401 SW First Street	Belle Glades	33430		G	0	0			Host Shelter
Discovery Key Elementary School	1	3550 Lyons Road	Lake Worth	33467	N	G	800	33,806		800	Secondary Shelter
First Baptist Church of Boca Raton		2350 Yamato Road	Boca Raton	33431		G	0	0			Host Shelter
Forest Hill SHS	3,4,6,7	8499 Forest Hill blvd	W. Palm Beach	33405	N	G	4,000	77,037		4,000	Hurricane Risk Shelter
Frontier Elementary School	1	6701 180th Avenue, North	Loxahatchee	33470	N	G	800	33,489		800	Hurricane Risk Shelter
Glades Central High School	4, 5	1001 SW Avenue M	Belle Grade	33430	R	G	2,244	33,662		3,800	Hurricane Risk Shelter
Good Shepard Church		1800 Bacom Point Road	Pahokee	33476		G	0	0			Host Shelter, in Cat 3 Zone
Heritage ES	bldg 1- dining/stage	5100 Melaleuca Lane	Greenacres	33463		G	1,689	33,773		500	not surveyed
Hidden Oaks ES	1	7685 S. Military Trail	Lake Worth	33463		G	0	0			not shelter per school
Independence Middle	4	4001 Greenw	Jupiter	33410	N	G	410	8,200		410	Hurricane Risk Shelter
John I. Leonard HS	2,3,4,6,7,8,9,10,11	4710 10th Avenue	Greenacres	33463	N	G	3,500	70,000		3,500	Hurricane Risk Shelter
Lake Worth Middle School	1,2,3,4	1300 Barnett Drive	Lake Worth	33460	R	G	1,339	20,086			Secondary Shelter
Lakeshore Middle School	2,3,4,7, 50	425 West Canal Street	Belle Grade	33430	N	G	2,800	44,493		2,800	Hurricane Risk Shelter
McLeod Bethune ES	1	1501 Aveune U	Riviera Beach	33404		G	1,818	36,383		500	Secondary Shelter
Mt. Calvary First Baptist Church		180 SW 10th Avenue	South Bay	33493		G	0	0			Host Shelter
Mt. Calvary Missionary Baptist Church		399 Canal Street	South Bay	33493		G	0	0			Host Shelter
North Palm Beach Community Center		120 Prosperity Farms Road	North Palm Beach	33408		G	0	0			Host Shelter, in Cat 5 Zone
Odyssey Middle School	4	6161 Woolbright Road	Boynton Beach	33437	N	G	515	10,300			Hurricane Risk Shelter
Olympic Heights Comm. HS		20101 Lyons Road	Boca Raton	33437	R	G	1,900	38,000			Secondary Shelter
Omni Middle School	C, D,F, G	5775 Jog Road	Boca Raton	33496	R	G	1,510	22,656			Secondary Shelter
Our Savior Lutheran Church		1615 Lake Avenue	Lake Worth	33460		G	0	0			Host Shelter
Pahokee Recreation Center	Gym	360 East 1st Street	Pahokee	33476		G	0	0			Host Shelter, in cat 3/4 zone
Palm Beach Central High School (part)	2,3,4,5,6,7,	8499 W. Forest Hill Blvd.	Wellington	33414	N	G	3,914	78,275		5,750	Gym is SpnS rest general
Palm Beach Community College	Gym	4200 Congress Avenue	Lake Worth	33461		G	0	0			Host Shelter
Palm Beach Gardens Community Center		4404 Burns Road	Palm Bch Gardens	33410		G	0	0			Host Shelter
Palm Beach Gardens Community HS	1	4246 Holly Drive	Palm Bch Gardens	33410	N	G	1,213	24,262			
Palm Beach Gardens Community HS	2	4246 Holly Drive	Palm Bch Gardens	33410	N	G	1,346	26,925			
Palm Beach Gardens Community HS	3	4246 Holly Drive	Palm Bch Gardens	33410	N	G	1,631	32,622			
Palm Beach Gardens Community HS	4	4246 Holly Drive	Palm Bch Gardens	33410	N	G	706	14,125			
Palm Beach Gardens Community HS	5	4246 Holly Drive	Palm Bch Gardens	33410	N	G	2,128	42,560			
Palm Beach Gardens Moose Lodge		3600 RCA Boulevard	Palm Bch Gardens	33410		G	0	0			Host Shelter
Park Vista Community High School	2,5,6,7,8,9,10	7900 Jog Rd.	Boynton Beach	33427	N	G	4,376	65,641		4,950	Hurricane Risk Shelter
Riverside Community Center		10170 Riverside Drive	Palm Bch Gardens	33410		G	0	0			Host Shelter
Seminole Ridge HS	2,3,4,5,6,7,10	4601 Seminole Pra	Loxahatchee	33470	N	G	3,900	98,279		3,900	Hurricane Risk Shelter
South Florida Fair Grounds	Expo 1	9067 Southern Boulevard	W Palm Beach	33411		P	0	0			Host Shelter / PsNS
Spanish River Presbyterian Church		2400 Yamato Road	Boca Raton	33434		G	0	0			Host Shelter
St. Johns First Missionary Baptist Church		600 SW 8th Street	Belle Glades	33430		G	0	0			Host Shelter
Village Academy School		400 SW 12th Avenue	Delray Beach	33444		G	0	0			Host Shelter
W. Boca Raton Community High School	2,3,4,5,6,7,9,12	12811 Glades Rd.	Boca Raton	33428	N	G	3,900	99,132		3,900	Hurricane Risk Shelter

**2012 Statewide Emergency Shelter Plan**

<b>PALM BEACH</b>											
W.B. Duncan Middle School	3,4,6,7	5150 117th Court North	Palm Bch Gardens	33418	R	G	1,573	23,595			Secondary Shelter
Wellington Landings Middle School	1,2,3, 4	1100 Areo Club Drive	W Palm Beach	33414	R	G	1,600	25,786			Secondary Shelter
Westgate Elementary School		1545 Loxahatchee Road	W Palm Beach	33414	R	G	2,293	45,861		720	Hurricane Risk Shelter
Wm. T. Dwyer High School	1, 2, 8	13601 N Military Trail	Palm Bch Gardens	33418	R	G	2,343	58,579		1,900	Hurricane Risk Shelter
							0	0			
<b>TOTALS FOR PALM BEACH COUNTY</b>							<b>70,396</b>	<b>1,279,838</b>	<b>0</b>	<b>44,850</b>	<b>0</b>
<b>Year 2012</b>	<b>Shelter Capacity In People</b>	<b>Shelter Demand In People</b>	<b>Surplus/ Deficit In People</b>	<b>Shelter Capacity (ft2)</b>			<b>Surplus/ Deficit (ft2)</b>	<b>Result</b>			
Storm Category 4/5	70,396	28,467	41,929	1,279,838			710,498				
<b>Special Needs Storm Shelters</b>											
<b>Name</b>	<b>Bldg #</b>	<b>Address</b>	<b>City</b>	<b>Zip</b>			<b>SpNS Capacity (spaces @ 60sf) (meets ARC 4496)</b>	<b>SpNs Capacity (sf) (meets ARC 4496)</b>	<b>SpNS Capacity (spaces @ 60sf) (does not meet ARC 4496)</b>	<b>local planned usage</b>	<b>Comments</b>
South Florida Fair Expo		9067 Southern Boulevard	W Palm Beach	33411	R	P	550	33,000		550	"Special Care" 550 Spn-550 caregivers
Palm Beach Central HS (Part)	8-Gym	8499 W. Forest Hill Blvd.	Wellington	33414	N	P	250	15,000		250	250 Spn - 250 caregivers
							0	0			
							0	0			
							0	0			
								0			
<b>Year 2012</b>	<b>SpNs Shelter Capacity In Spaces (meets ARC 4496)</b>	<b>SpNs Shelter Demand In Spaces</b>	<b>Surplus/ Deficit In Spaces</b>	<b>SpNs Shelter Capacity (ft2)</b>			<b>Surplus/ Deficit (ft2)</b>	<b>Result</b>			
Storm Category 4/5	800	5,336	-4,536	48,000			-272,160				

2012 Statewide Emergency Shelter Plan

PASCO													
Name	Bldg. #	Address	City	Zip	Retrofit ted (R) or New Constru ction (N)	Gen eral (G), PSN (P), Pet - Frie ndly (A)	Host Capacity In People	Total Risk Capacity In People (Meets ARC 4496)	Total Risk Capacity (ft <sup>2</sup> ) (Meets ARC 4496) <sup>2</sup>	Risk Capacity In People (Does not Meet ARC 4496 or Not Yet Surveyed)	Local Planned Usage (reported capacity)	Funding Source: Local (L), State (S), Federal (F), and Program Name	Comments
Anclote ES		3610 Madison Street	Elfers	34652			N/A	0	0	1,267			21.5' SLOSH
Bayonet Point Middle School		11125 Little Road	New Port Richey	34654			N/A	0	0	478			
Calusa Elementary School	4	7520 Orchid Lake Road	New Port Richey	34654	R	G	N/A	126	1,883		181	S/HMGP	7/15/03 completion
Centennial Elementary School	7	38501 Centennial Road	Dade City	33525			N/A	0	0				
Centennial Middle School	2	38501 Centennial Road	Dade City	33525	R	G	N/A	882	14,350		882	L/schoolboard	
Chasco Elementray/Middle School	2-1st flr	7720 Ridge Road	New Port Richey	34654	N	G	N/A	425	8,695		425	L/schoolboard	
Chasco Elementray/Middle School	2-2nd flr	7720 Ridge Road	New Port Richey	34654	N	G	N/A	425	9,399		425	L/schoolboard	
Connerton Elementary School	3, 4 & 5	9300 Flourish Drive	Land O'Lakes	34637	N	G	N/A	1,168	22,544		1168	L/schoolboard	reported by EM 2011
Cypress Elementary School		10055 Sweet Bay Court	New Port Richey	34654			N/A	0	0	187			
Denham Oaks Elementary School	1	14220 Oak Grove Blvd	Lutz	33548	R	G	N/A	258	3,869		257	S/HMGP	
Denham Oaks Elementary School	2	14220 Oak Grove Blvd	Lutz	33548	R	G	N/A	380	5,703		380	S/HMGP	
Denham Oaks Elementary School	3	14220 Oak Grove Blvd	Lutz	33548	R	G	N/A	203	3,042		203	S/HMGP	
Denham Oaks Elementary School	5	14220 Oak Grove Blvd	Lutz	33548	R	G	N/A	227	5,686		227	S/HMGP	
Denham Oaks Elementary School	6	14220 Oak Grove Blvd	Lutz	33548	R	G	N/A	429	7,454		429	S/HMGP	
Denham Oaks Elementary School	7	14220 Oak Grove Blvd	Lutz	33548	R	G	N/A	204	3,057		204	S/HMGP	
Double Branch ES	Target 2008	31500 Chancey Pkwy	Wesley Chapel	33543	N	G	N/A	787	15,740			Local	
Gulf High School		5355 School Road	New Port Richey	34652			N/A	0	0	1,595		S/HMGP	Structural Problems, 4.5' SLOSH
Hudson High School		14410 Cobra Way	Hudson	34669			N/A	0	0	3,225		S/HMGP	Structural Problems,5.5' SLOSH
Hudson High School		14410 Cobra Way	Hudson	34669			N/A	0	0			S/HMGP	Structural Problems,5.5' SLOSH
JW Mitchell HS	7	2323 Little Road,	New Port Richey	34655	R	G	N/A	0	0		1,230	S-1467-2004	4' SLOSH
JW Mitchell HS	8	2323 Little Road,	New Port Richey	34655	R	G	N/A	0	0		607	S-1467-2004	4' SLOSH
JW Mitchell HS	9	2323 Little Road,	New Port Richey	34655	R	G	N/A	0	0		400	S-1467-2004	4' SLOSH
Lacoochee Elementary School	11	38815 Cummer Road	Lacoochee	33525	R	G	N/A	60	900		101	S/HMGP	
Lacoochee Elementary School	12	38815 Cummer Road	Lacoochee	33525	R	G	N/A	383	5,749		503	S/HMGP	
Lacoochee Elementary School	13	38815 Cummer Road	Lacoochee	33525	R	G	N/A	74	1,108		90	S/HMGP	
Longleaf Elementary School	4	2323 Little Road	New Port Richey	34655	N	G	N/A	1,060	26,500		804	Local	Opens 8/05
New River ES	4	4710 River Glen Blvd	Wesley Chapel	33545	N	G	N/A	787	15,740		787	Local	2008-2009
Northwest Elementary School		14302 Cobra Way	Hudson	34669			N/A	0	0	1,403			4.2' SLOSH
Oakslead ES	4-Classrooms	19925 lake Patience RD	Land O'Lakes	34639	N	G	N/A	775	14,580		775	L-School Board	
Odessa Elementary School	2, 3 & 4	1874 Ketzal Drive	New Port Richey	34655	N	G	N/A	1,505	30,171		1505		reported by EM 2011
Pasco Hernando Comm. College	Target 2008				N	G	N/A	0	0			L-College Funds	
Pasco High School	16	36850 SR 52	Dade City	33525	R	G	N/A	0	0		0	S/HMGP	Deleted due to current condition
Pasco High School	17	36850 SR 52	Dade City	33525	R	G	N/A	0	0		0	S/HMGP	Deleted due to current condition
Pasco High School	18	36850 SR 52	Dade City	33525	R	G	N/A	0	0		0	S/HMGP	Deleted due to current condition
Pineview Elementary School	1,2,3,4	5333 Parkway Blvd	Land O'Lakes	33549	N	G	N/A	804	16,080		804	Local EHPA	8/1/03 completion
Pineview Middle School	1	5334 Parkway Boulevard	Land O'Lakes	34639	R	G	N/A	0	0	74	74	F. S	
Pineview Middle School	5	5334 Parkway Boulevard	Land O'Lakes	34639	R	G	N/A	0	9,546		0	S/HMGP	pets only (300pets)
Raymond B. Stewart Middle School	10	38505 Tenth Avenue	Zephyrhills	33540	R	G	N/A	242	4,095		242	S/HMGP	
Raymond B. Stewart Middle School	9A/ 5	38505 Tenth Avenue	Zephyrhills	33540	R	G	N/A	122	2,879		122	S/HMGP	
RB Stewart MS	12-Cafeteria	38505 Tenth Avenue	Zephyrhills	33540	N	G	N/A	487	9,740		487	L-School Board	
Fasano Regional Evacuation Shelte	1	11611 Denton Ave	Hudson	34667	N	G,A	N/A	666	20,000		666	L/F HMGP	500 GP + 166 PSN
River Ridge Middle/High School	1	11646 Town Center Road	New Port Richey	34654	R	G	N/A	339	4,812		135	S/HMGP	
River Ridge Middle/High School	2	11646 Town Center Road	New Port Richey	34654	R	G	N/A	517	7,761		339	S/HMGP	
River Ridge Middle/High School	3	11646 Town Center Road	New Port Richey	34654	R	G	N/A	636	15,899		515	S/HMGP	
River Ridge Middle/High School	4	11646 Town Center Road	New Port Richey	34654	R	P	N/A	0	0		271	S/HMGP	
River Ridge Middle/High School	5	11646 Town Center Road	New Port Richey	34654	R	G	N/A	665	16,623		238	S/HMGP	
River Ridge Middle/High School	24	11646 Town Center Road	New Port Richey	34654	R	G	N/A	0	0	0		S/HMGP	Structural Problems
River Ridge Middle/High School	31	11646 Town Center Road	New Port Richey	34654	R	G	N/A	236	5,900		236	S/HMGP	
River Ridge Middle/High School	23-1st fl	11646 Town Center Road	New Port Richey	34654	R	P	N/A	0	0			S/HMGP	SEE SpNS
River Ridge Middle/High School	23-2nd flr	11646 Town Center Road	New Port Richey	34654	R	G	N/A	825	14,000		829	S/HMGP	
Saint Leo University	4	33701 SR 52	St Leo	33525	N	G	N/A	291	5,820		291	L	EHPA
Saint Leo University	22	33701 SR 52	St Leo	33525	R	G	N/A	0	0			S/EMPATF	
Saint Leo University	24	33701 SR 52	St Leo	33525	R	G	N/A	525	10,500			S/EMPATF	
Saint Leo University		33701 SR 52	St Leo	33525	R	G	N/A	231	4,620			S/EMPATF	
Saint Leo University	Bowman	33701 SR 52	St Leo	33525	R	P	N/A	0	0			S	
Saint Leo University	Bowman	33701 SR 52	St Leo	33525	R	G	N/A	0	0	145	145		
Saint Leo University	Lewis	33701 SR 52	St Leo	33525	R	G	N/A	0	0		461	S	
Saint Leo University	St. Edwards	33701 SR 52	St Leo	33525	R	G	N/A	346	6,920		525	S/EMPATF	
Schrader Elementary School	9	11041 Little Rd	New Port Richey	34654	R	G	N/A	0	0		850	Local EHPA	4/1/03 completed, 4.4' SLOSH
Seven Oaks Elementary	4	27633 Mystic Oak	Wesley Chapel	33544	N	G	N/A	1,060	26,500		804	Local	Opens 8/05
Seven Springs Middle School	C	2441 Little Road	New Port Richey	34654	R	G	N/A	0	0		0	S/EMPATF	Decommissioned per local Planned use
Shady Hills Elementary School		18000 Shady Hills Road	Spring Hill	34610			N/A	0	0	1,869			
Sunlake High School	Target 2008	3023 Sunlake Blvd	Land O'Lakes	34648	N	G	N/A	2,860	57,200		2,860	Local	
Thomas Weightman Middle School	2	30649 Wells Road	Zephyrhills	33544	R	G	N/A	326	4,885		389	S/HMGP	
Thomas Weightman Middle School	3	30649 Wells Road	Zephyrhills	33544	R	G	N/A	698	17,446		573	S/HMGP	

**2012 Statewide Emergency Shelter Plan**

<b>PASCO</b>													
Thomas Weightman Middle School	4	30649 Wells Road	Zephyrhills	33544	R	G	N/A	401	6,018		427	S/HMGP	
Thomas Weightman Middle School	5	30649 Wells Road	Zephyrhills	33544	R	G	N/A	234	3,969		234	S/HMGP	
Thomas Weightman Middle School	6	30649 Wells Road	Zephyrhills	33544	R	G	N/A	351	5,270		427	S/HMGP	
Thomas Weightman Middle School	8	30649 Wells Road	Zephyrhills	33544	R	G	N/A	401	6,018		427	S/HMGP	
Trinity ES	1,2,3,4	2209 Duck Slough Blvd	New Port Richey	34654	N	G	N/A	755	15,100		755	L/schoolboard	
Trinity Oaks ES	2	1827 Trinity Oaks Blvd	New Port Richey	34655	N	G	N/A	0	0		884	L-School Board	3.6' SLOSH
Fivay High School	all	SR52	Hudson	34667	N	G	N/A	0	0		0	L	Evac Zone D
Veterans Elementary School		26940 Progress Parkway	Wesley Chapel	33544	N	G	N/A	920	18,400		920	L-School Board	EHPA
Watergrass Elementary		32750 Overpass Road	Wesley Chapel	33545	N	G	N/A	775	15,500		775	L	
Wesley Chapel High School	1	30651 Wells Road	Wesley Chapel	33544	N	P	N/A	0	0			L/schoolboard	
Wesley Chapel HS	2	30651 Wells Road	Wesley Chapel	33544	R	P	N/A	0	0			S-1467-2004	Backup SpNS No Generator
Wesley Chapel HS	3	30651 Wells Road	Wesley Chapel	33544	R	G	N/A	1,143	16,780		1,143	S-1467-2004	
Wesley Chapel HS	5	30651 Wells Road	Wesley Chapel	33544	R	G	N/A	321	4,816		370	S-1467-2004	
Wesley Chapel Park	Target 2009				N	G	N/A	0	0		0	L/F/S-EMPA/HB	2008-2009
Wiregrass High School	4	2909 Mansfield Blvd	Wesley Chapel	33543	N	G	N/A	1,102	22,040		1,102	L-School Board	Generator Installed by State
Wiregrass High School	6	2909 Mansfield Blvd	Wesley Chapel	33543	N	G	N/A	317	6,340		317	L-School Board	
Wiregrass High School	7	2909 Mansfield Blvd	Wesley Chapel	33543	N	G	N/A	311	6,220		311	L-School Board	
Zephyrhills High School	1 Less Rm 10	6335 12 Street	Zephyrhills	33540	R	P	N/A	0	0	173		S/HMGP	dated info- wall/roof issues
Zephyrhills High School	chorus & bar	6335 12 Street	Zephyrhills	33540	R	G	N/A	0	0	1,740		S/HMGP	open span 68ft
<b>TOTALS FOR PASCO COUNTY</b>								<b>0</b>	<b>29,065</b>	<b>583,867</b>	<b>12,156</b>	<b>31,531</b>	<b>0</b>
<b>Year 2012</b>	<b>Shelter Capacity In People</b>	<b>Shelter Demand In People</b>	<b>Surplus/ Deficit In People</b>	<b>Shelter Capacity (ft2)</b>				<b>Shelter Demand (ft2)</b>	<b>Surplus/ Deficit (ft2)</b>	<b>Result</b>			
Storm Category 4/5	29,065	25,327	3,738	583,867				506,540	77,327				
<b>Special Needs Storm Shelters</b>													
<b>Name</b>	<b>Bldg #</b>	<b>Address</b>	<b>City</b>	<b>Zip</b>			<b>Emergency Powered HVAC?</b>	<b>SpNS Capacity (spaces @ 60sf) (meets ARC 4496)</b>	<b>SpNs Capacity (sf) (meets ARC 4496)</b>	<b>SpNS Capacity (spaces @ 60sf) (Does not Meet ARC 4496 or Not Yet Surveyed)</b>	<b>Local Planned Usage (reported capacity)</b>	<b>Funding Source: Local (L), State (S), Federal (F), and Program Name</b>	<b>Comments</b>
River Ridge MS	23 (1st floor)	11646 Town Center Road	New Port Richey	34654	R	P	Yes	310	13,970		421	S	Generator in question
St. Leo University	Bowman	33701 SR 52	St. Leo		R	P	Yes	101	4,550		115		Backup SpNS due to staffing issues
Wesley Chapel HS	2	30651 Wells Road	Wesley Chapel	33544	R	P	Yes	421	18,954		500	S-1467-2004	Backup SpNS due to staffing issues
Wiregrass High School	3	2909 Mansfield Blvd	Wesley Chapel	33543	N	P	Yes	485	21,806		600	L/S	
								0	0				
								0	0				
								0	0				
<b>Year 2012</b>	<b>SpNs Shelter Capacity In Spaces (meets ARC 4496)</b>	<b>SpNs Shelter Demand In Spaces</b>	<b>Surplus/ Deficit In Spaces</b>	<b>SpNs Shelter Capacity (ft2)</b>				<b>Shelter Demand (ft2)</b>	<b>Surplus/ Deficit (ft2)</b>	<b>Result</b>			
Storm Category 4/5	1,317	2,810	-1,493	79,020				168,600	-89,580				



**2012 Statewide Emergency Shelter Plan**

**PINELLAS**

Name	Bldg. #	Address	City	Zip	Retrofitted (R) or New Construction (N)	General (G), PSN (P), Pet-Friendly (A)	Total Risk Capacity In People (Meets ARC 4496) <sup>2</sup>	Total Risk Capacity (ft <sup>2</sup> ) (Meets ARC 4496)	Risk Capacity In People (Does not Meet ARC 4496 or Not Yet Surveyed)	Local Planned Usage (reported capacity) (10sf pp)	Funding Source: Local (L), State (S), Federal (F), and Program Name	Comments
Bauder Elementary School	1	12755 86 Avenue North	Seminole	33776	R	G	0	0	580	1,159	L	open spans-formboardroof-walls issues.
Azalea ES	16	1680 74th Street N	St. Petersburg	33710	N	G	270	5,405			L	per Ehpa list-2009
Bardmoor ES	3	8900 Greenbrier Road	Seminole	33777	N	G	0	0			L	per Ehpa list-2009, 6.3' SLOSH
Blanton ES	16	6400 54th Avenue N	St. Petersburg	33709	N	G	0	0			L	per Ehpa list-2009, 1.97' SLOSH
Brooker Creek E S	4 & 5 (1st floors)	3130 Forelock Rd	Tarpon Springs	34688	R	G	704	10,560		1,389	HMGP	25ft amsl- FFE, < 1' SURGE
Campbell Park ES		1051 7th Ave S	St. Petersburg	33705	N	G	1,330	26,600		2,660		
Carwise Middle School	5&6	3301 Bentley Drive	Palm Harbor	34684	R	G, P	2,654	39,812		4,043	HMGP	PBSJ- report
Countryside High School	6	300 McMullen Booth	Clearwater	33781	R	G	90	1,798		0	HMGP	meets ARC 4496 per PBSJ report
Doug Jamerson ES	4	1200 37th St. S	St. Petersburg	33714	R	G	340	6,800		1,347	S-1508-2005	
Doug Jamerson ES	5	1200 37th St. S	St. Petersburg	33714	R	G	340	6,800			S-1508-2005	
Doug Jamerson ES	4&5	2350 22 Ave S	St Petersburg	33714	R	GP	61	1,210				
Dunedin Community Center		1920 Pinehurst RD	Dunedin	34698	N	G	0	0		800		9.7' SLOSH
Dunedin ES		900 Union Street	Dunedin	34698	N	G	0	0		3,279		
Dunedin ES (new)	1	901 Union Street	Dunedin	34699	N	G	571	11,423				
Dunedin ES (new)	2	902 Union Street	Dunedin	34700	N	G	280	5,604				
Dunedin ES (new)	3	903 Union Street	Dunedin	34701	N	G	227	4,547				
Dunedin ES (new)	4	904 Union Street	Dunedin	34702	N	G	314	6,284				
Dunedin Highland Middle School	4	70 Patricia Avenue	Dunedin	34698	N	G,A	332	6,634				
Dunedin Highland Middle School	5	70 Patricia Avenue	Dunedin	34698	N	G	617	11,296				
East Lake High School	6	1300 Silver Eagle Drive	Tarpon Springs	34689	R	G & P	0	0			S-1395B	PBSJ report, 1.7' SLOSH
East Lake High School	2 (1st floor)	1300 Silver Eagle Drive	Tarpon Springs	34689	R	G & P	0	0			S-1395B	PBSJ report, 1.7' SLOSH
East Lake High School	2,3,6,9	1300 Silver Eagle Drive	Tarpon Springs	34689	R	G & P	0	0		4,041	S-1395B	1.7' SLOSH
East Lake High School	3 (1st floor)	1300 Silver Eagle Drive	Tarpon Springs	34689	R	G & P	0	0			S-1395B	PBSJ report, 1.7' SLOSH
East Lake High School	9 (1st floor)	1300 Silver Eagle Drive	Tarpon Springs	34689	R	G & P	0	0			S-1395B	PBSJ report, 1.7' SLOSH
Eishenhower ES	7	2800 Drew Street	Clearwater	33759	N	G	284	5,672				
Fairmont Park Elementary School	4&5	575 41 Street South	St Petersburg	33711	R	G,p	61	1,220				PBSJ Report
Fairmont Park ES	4	575 41 Street South	St Petersburg	33711	R	G	340	6,800		1,157	S-1508-2005	PBSJ Report
Fairmont Park ES	5	575 41 Street South	St Petersburg	33711	R	G	340	6,800			S-1508-2005	PBSJ Report
Fuguitt ES	12	13010 101st Street	Largo	33773	N	G	0	0				11.3' SLOSH
Gibbs High School	campus wide	850 34 Street South	St Petersburg	33711		G	0	0		6,550	F,S	replace old bldgs.
Gibbs Senior High School	2	851 34 Street South	St Petersburg	33712	R	G	1,631	32,616			L	
Gibbs Senior High School	3	852 34 Street South	St Petersburg	33713	R	G	982	19,647			L	
Gibbs Senior High School	4	853 34 Street South	St Petersburg	33714	R	G	1,652	33,038			L	
Gibbs Senior High School	5	854 34 Street South	St Petersburg	33715	R	G	776	15,529			L	
Gibbs Senior High School	6	855 34 Street South	St Petersburg	33716	R	G	429	8,583			L	
Gulfport ES	3	2014 52nd Street S	St. Petersburg	33707	R	G	208	4,156			L	
Gulfport ES	4	2014 52nd Street S	St. Petersburg	33707	R	G	542	10,835			L	
Gulfport ES	5	2014 52nd Street S	St. Petersburg	33707	R	G	510	10,205			L	
Gulfport ES	7	2014 52nd Street S	St. Petersburg	33707	R	G	265	5,309			L	
Gulfport ES	campus wide	2014 52nd Street S	St. Petersburg	33707		G	0	0		2,660	L	
High Point ES (New)	3	5921 150th Ave	Clearwater	33760	N	G	0	0			L	6.2' SLOSH
High Point ES (New)	4	5921 150th Ave	Clearwater	33760	N	G	0	0			L	6.2' SLOSH
High Point ES (New)	5	5921 150th Ave	Clearwater	33760	N	G	0	0			L	6.2' SLOSH
High Point ES (New)	6	5921 150th Ave	Clearwater	33760	N	G	0	0			L	6.2' SLOSH
High Point ES		5921 150th Ave	Clearwater	33760	N	G	0	0		3,325	L	6.2' SLOSH
Kennedy Middle School	1 (1st flr halls)	1660 Palmetto Street	Clearwater	33755	R	G & P	0	0	1,756	3,512	L	questions on walls/roof.
Largo High School	11 (1st floor)	410 N Missouri Avenue	Largo	33770	R	G	745	11,172		1,074	L	wall questions.
Lealman Intermediate Middle School	1-cr	4900 28th St. N	St Petersburg	33714	N	G	462	9,235		3,504	F,S,L	replace old bldgs

**2012 Statewide Emergency Shelter Plan**

**PINELLAS**

Lealman Intermediate Middle School	2-dining	4900 28th St. N	St. Petersburg	33714	R	G	110	2,201				
Lealman Intermediate Middle School	4-gym	4900 28th St. N	St Petersburg	33714	N	G	480	9,552				
Lealman Intermediate Middle School	5-ESE,multipurpose	4900 28th St. N	St Petersburg	33714	R	G	569	11,386				
Leila Davis ES	5	2830 Landmark Drive	Clearwater	33761	N	G	318	6,364				
McMullen Booth E S	4 (1st floor)	3025 union st	Clearwater	33579	R	G	267	5,330	1,327		HMGP	
McMullen Booth E S	5 (1st floor)	3025 union st	Clearwater	33579	R	G	267	5,330			HMGP	
McMullen Booth E S	7	3025 union st	Clearwater	33759	N	G	209	4,186				
Mildred Helms ES	12	561 S. Clearwater-Largo RD	Largo	33770	N	G	470	9,406				
New Heights Elementary School	campus wide	3901 37th St. N	St. Petersburg	33714	N	G	0	0	3,456			
New Heights Elementary School	2	3902 37th St. N	St. Petersburg	33715	N	G	0	0				library
New Heights Elementary School	3	3902 37th St. N	St. Petersburg	33715	N	G	239	4,772				
New Heights Elementary School	4	3903 37th St. N	St. Petersburg	33716	N	G	487	9,746				
New Heights Elementary School	5	3904 37th St. N	St. Petersburg	33717	N	G	465	9,305				
New Heights Elementary School	6	3905 37th St. N	St. Petersburg	33718	N	G	425	8,497				
							0	0				
Northside Baptist Church		6000 38 Avenue North	St Petersburg	33710			0	0	758	758		2.8' SLOSH
Palm Harbor Middle School	4 (1st floor)	1800 SR 584	Palm Harbor	34683	R	G	487	9,739				per PBSJ report,
Palm Harbor Middle School	5 (1st floor)	1800 SR 584	Palm Harbor	34683	R	G	561	11,216				per PBSJ report,
Palm Harbor Middle School		1800 SR 584	Palm Harbor	34683	R	G	0	0	2,848		HMGP	good-1st floor-impact glass
Palm Harbor University HS	2	1900 Omaha Street	Palm Harbor	34683	R	G, P	368	7,350				per PBSJ report
Palm Harbor University HS	3	1900 Omaha Street	Palm Harbor	34683	R	G, P	391	7,815				per PBSJ report
Palm Harbor University HS	4	1900 Omaha Street	Palm Harbor	34683	R	G, P	613	12,250				per PBSJ report
Palm Harbor University HS	5	1900 Omaha Street	Palm Harbor	34683	R	G, P	719	14,372			HMGP	per PBSJ report
Palm Harbor University HS	6	1900 Omaha Street	Palm Harbor	34683	R	G, P	250	4,993				per PBSJ report
Palm Harbor University HS	7	1900 Omaha Street	Palm Harbor	34683	R	G, P	362	7,233				per PBSJ report
Palm Harbor University HS	8	1900 Omaha Street	Palm Harbor	34683	R	G, P	483	9,656				per PBSJ report
Palm Harbor University HS	9	1900 Omaha Street	Palm Harbor	34683	R	G, P	183	3,660				per PBSJ report
Palm Harbor University HS	10	1900 Omaha Street	Palm Harbor	34683	R	G, P	510	10,191				per PBSJ report
Palm Harbor University HS	11	1900 Omaha Street	Palm Harbor	34683	R	G, P	469	9,381			HMGP	per PBSJ report
Palm Harbor University HS	12	1900 Omaha Street	Palm Harbor	34683	R	G, P	83	1,660				per PBSJ report
Palm Harbor University HS		1900 Omaha Street	Palm Harbor	34683	R	G, P	0	0	3,022		HMGP	
Pinellas Central ES	6	10501 58th Street	Pinellas Park	33782	N	G	0	0			L	9' SLOSH
Pinellas Park High School	1	6305 118 Avenue North	Pinellas Park	33771	R	G, P	0	0	2,075	4,150	HMGP	wall questions also unprotected higher windows? Surge?, 4.1' SLOSH
Ridgecrest ES	17	1901 119th Street N	Largo	33778	N	G	129	2,587				
Ross Norton Recreation Center		1426 Martin Luther King Jr A	Clearwater		N	G	303	6,060		607	L	
Safety Harbor ES	11	535 5th Avenue N	Safety Harbor	34695	N	G	0	0			L	7.87' Slosh
Safety Harbor M. S. (2,3,4,5,6,7,9,11,12,14 & 15)		125 7 Street North	Safety Harbor	34695	R	G & P	0	0			L	surge issues. 8.6' SLOSH
Safety Harbor MS	2 (2nd floor) & 3 (2nd floor)	901 1ST Ave North	Safety Harbor	34695	N	G	0	0		7,707	L	2nd floor only- surge issues- in Cat 4 zone. Both floors in exiting storm. 8.6' SLOSH
Sanderlin ES	4	2350 22nd Ave S	St. Petersburg		R	G	337	6,800				S-1508-2005
Sanderlin ES	5	2350 22nd Ave S	St. Petersburg		R	G	338	6,800				S-1508-2005
Sanderlin ES	4&5	2350 22nd Ave S	St Petersburg	33712	R	G&P	56	1,120	1,255			not done 1435A
Sanderlin ES	7	2350 22nd Ave S	St. Petersburg	33712	N	G	129	2,587			L	
Seventy-Fourth Streeth ES	9	3801 74th Street N	St. Petersburg	33709	N	G	129	2,587			L	
Sexton ES	4 & 5	1997 54th Ave N	St. Petersburg		R	G & P	655	9,977		1,372	L	
Skycrest ES	6	10 N. Corona Avenue	Clearwater	33765	N	G	531	10,620			L	
Skyview ES	11	8601 60th Street N	Pinellas Park	33782	N	G	0	0			L	6.93' Slosh
Southern Oak ES	13	9101 Walsingham Road	Largo	33733	N	G	0	0			L	11.16' Slosh
St. Petersburg High School	4 & 5	2501 5th Avenue North	St Petersburg	33713	R	G, P	1,755	35,100	2,167		HMGP	PBSJ report,
Tarpon Springs Middle School	4 & 5 (first floors	500 N Florida Avenue	Tarpon Springs	34689	R	G, P	0	0	2,617		L	impact glass. 5.2' SLOSH
Thurgood Marshall Middle School	1 thru 6	3901 22 Ave. S.	St Petersburg	33711	N	G/A	0	0		6,918	F,S	old bldgs-surge 7.7' SLOSH
<b>TOTALS FOR PINELLAS COUNTY</b>							<b>31,504</b>	<b>605,419</b>	<b>5,169</b>	<b>78,704</b>		<b>0</b>

**2012 Statewide Emergency Shelter Plan**

**PINELLAS**

Year 2012	Shelter Capacity In People	Shelter Demand In People	Surplus/Deficit In People	Shelter Capacity (ft2)			Surplus/Deficit (ft2)	Result				
Storm Category 4/5	31,504	42,370	-10,866	605,419			-241,981					
<b>Special Needs Storm Shelters</b>												
Name	Bldg #	Address	City	Zip			SpNS Capacity (spaces @ 60sf) (meets ARC 4496)	SpNs Capacity (sf) (meets ARC 4496)	SpNS Capacity (spaces @ 60sf) (does not meet ARC 4496)	Local Planned Usage (reported capacity) (40sf pp)	Funding Source: Local (L), State (S), Federal (F), and Program Name	Comments
Dunedin Highland MS	2	70 Patricia Ave	Dunedin	34698	N	P	379	22,727		1,596		400 pet/pbsj study
Dunedin Highland MS	3	70 Patricia Ave	Dunedin	34698	N	P	426	25,534				pbsj-study
John Hopkins Middle Schoo	5&6	701 16 Street South	St Petersburg	33705	R	G & P	407	24,456		1,113	L	pbsj-study
Oak Grove Middle School	1, 6	1370 S Belcher Road	Clearwater	33764	N	P,A	1,056	63,360		1,584		Spns-1584,Pet 550
Year 2012	SpNs Shelter Capacity In Spaces (meets ARC 4496)	SpNs Shelter Demand In Spaces	Surplus/Deficit In Spaces	SpNs Shelter Capacity (ft2)			Surplus/Deficit (ft2)	Result				
Storm Category 4/5	2,268	7,436	-5,168	136,080			-310,080					

2012 Statewide Emergency Shelter Plan

POLK												
Name	Bldg. #	Address	City	Zip	Retro fitted (R) or New Constructi	Gener al (G), PSN (P), Pet - Friend ly (A)	Total Risk Capacity In People (Meets ARC 4496)	Total Risk Capacity (ft <sup>2</sup> ) (Meets ARC 4496)	Risk Capacity In People (Does not Meet ARC 4496 or Not Yet Surveyed)	Local Planned Usage (reported capacity)	Funding Source: Local (L), State (S), Federal (F), and Program Name	Comments
Alta Vista ES	9	801 Scenic Hwy	Haines City	33844	N	G/A	345	5,182		432	L	open 2006
Auburndale High School		1 Bloodhound Trail	Auburndale	33823			0	0	644			
Bartow Adult Day Care Center	center				R	G	0	0			EMPA	
Bartow Family Health Care Center		5 Brice Boulevard	Bartow	33830	R	P	0	0	0			
Bartow Middle School		550 E Clover Street	Bartow	33830			0	0	247			
Bartow Senior High School	Bldg 23- cafeteria	1270 S Broadway	Bartow	33830	N	G	436	6,536		495	L	open 2004
Blake Elementary School		510 Hartsell Avenue	Lakeland	33801			0	0	203			
Boone Middle School		225 S 22nd Street	Haines City	33844			0	0	114			
Caldwell Elementary School		141 Dairy Road	Auburndale	33823			0	0	110			
Chain of Lakes ES	6	7001 SR 653	Winter Haven	33884	N	G	143	2,860			L	open 2005
Chain of Lakes ES	3th- 2nd floor	7001 SR 653	Winter Haven	33884	N	G	454	6,804		521	L	open 2005
Chain of Lakes ES	3th-1st floor	7001 SR 653	Winter Haven	33884	N	G	495	7,421		521	L	open 2005
Chain of Lakes ES	4th- 1st floor	7001 SR 653	Winter Haven	33884	N	G	448	6,714		522	L	open 2005
Chain of Lakes ES	4th-2nd floor	7001 SR 653	Winter Haven	33884	N	G	483	7,248		521	L	open 2005
Chain of Lakes ES	5-Dining	7001 SR 653	Winter Haven	33884	N	G	323	4,840		327	L	open 2005
Churchwell Elementary School		8201 Park Byrd Road	Lakeland	33809			0	0	259			
Combee ES	17	2805 Morgan Combee Road	Lakeland	33805	N	G	358	5,371		342	L	open 2006
Crystal Lake Middle School		2410 N Crystal Lake Drive	Lakeland	33802			0	0	260			
Davenport Elementary School		8 Palmetto Street	Davenport	33837			0	0	20			
Denison Middle School		400 Avenue A SE	Winter Haven	33880			0	0	139			
Dundee ES	5				N	G	0	0			L	No Ehpa per county
Eastside Elementary School		1820 E Johnson Avenue	Haines City	33844			0	0	94			
Frostproof Elementary School		113 W 3rd Street	Frostproof	33843			0	0	456			
Frostproof Junior/Senior High School		1000 N Palm Avenue	Frostproof	33843			0	0	214			
Ft. Meade Junior/Senior High School		700 Edgewood Drive	Ft. Meade	33841			0	0	136			
George Jenkins High School		6000 Lakeland Highlands Rd	Lakeland	33813			0	0	359			
Haines City Adult Day Care Center	center				R	G	0	0			EMPA	
Haines City High School	1	2800 Hornet Drive	Haines City	33844	R	G	0	0	263		S, F	
Haines City High School	3	2800 Hornet Drive	Haines City	33844	R	G	0	0			S, F	
Haines City High School	6	2800 Hornet Drive	Haines City	33844	R	G	0	0			S, F	
Haines City High School	7	2800 Hornet Drive	Haines City	33844	R	G	0	0			S, F	
Haines City High School	8	2800 Hornet Drive	Haines City	33844	N	G	429	6,431		559	L	open 2003
Haines City High School	18	2800 Hornet Drive	Haines City	33844	R	G	0	0			S, F	
Highlands Grove Elementary	3 First Floor	4510 Lakeland Highlands Rd	Lakeland	33813	N	G	461	6,921		582	L	
Highlands Grove Elementary	3 Second Floor	4510 Lakeland Highlands Rd	Lakeland	33813	N	G	557	8,348		585	L	
Highlands Grove Elementary	4 First Floor	4510 Lakeland Highlands Rd	Lakeland	33813	N	G	477	7,149		582	L	
Highlands Grove Elementary	4 Second Floor	4510 Lakeland Highlands Rd	Lakeland	33813	N	G	474	7,105		585	L	
Highlands Grove Elementary	5 Dining	4510 Lakeland Highlands Rd	Lakeland	33813	N	G	332	4,981		435	L	Per County
Horizons ES	3-1st Floor	1700 Forest Lake Drive	Davenport	33837	N	G	462	6,924		582	L	Per County
Horizons ES	3-2nd Floor	1700 Forest Lake Drive	Davenport	33837	N	G	571	8,564		585	L	Per County
Horizons ES	4-1st Floor	1700 Forest Lake Drive	Davenport	33837	N	G	475	7,122		582	L	Per County
Horizons ES	4-2nd Floor	1700 Forest Lake Drive	Davenport	33837	N	G	484	7,263		585	L	Per County
Horizons ES	5-Dining	1700 Forest Lake Drive	Davenport	33837	N	G	358	5,366		444	L	Per County
Jewett School of the arts	7	2250 8th Str NE	Winter Haven	33881	N	G	353	5,299		590	L	open 2002
Jewett School of the Arts	9	2250 8th Str NE	Winter Haven	33881	N	G	447	6,707		417	L	open 2006
Jewett School of the arts (Arts Classrms)	8	2250 8th Str NE	Winter Haven	33881	N	G	173	2,596		190	L	open 2002
Karen Siegel Academy (General classrms)	Bldg 7-cafeteria	935 North Buena Vista	Lake Alfred	33850	N	G	68	1,018		78	L	open 2004
Kathleen ES	11	3515 Sheretz Road	Lakeland	33810	N	G	536	8,035		651	L	open 2006
Kathleen High School		2600 N Crutchfield Road	Lakeland	33809			0	0	234			
Kathleen Middle School		3627 Kathleen Pine Road	Lakeland	33810			0	0	35			
Lake Alfred Elementary School		550 E Cummings Street	Lake Alfred	33850			0	0	143			
Lake Gibson High School	14 First Floor	7007 N Socrum Loop	Lakeland	33809	N	G	420	6,300		417	L	
Lake Gibson High School	14 Second Floor	7007 N Socrum Loop	Lakeland	33809	N	G	377	5,651		417	L	
Lake Gibson Middle School		6901 N Socrum Loop	Lakeland	33809			0	0	305			
Lake Marion Creek School	2 Gym	3055 Lake Marion Creek Rd	Poinciana	34759	N	G	580	8,694		512	L	
Lake Marion Creek School	3 First Floor	3055 Lake Marion Creek Rd	Poinciana	34759	N	G	575	8,626		802	L	

**2012 Statewide Emergency Shelter Plan**

POLK												
Lake Marion Creek School	3 Second Floor	3055 Lake Marion Creek Rd	Poinciana	34759	N	G	801	12,008		847	L	
Lake Marion Creek School	5 First Floor	3055 Lake Marion Creek Rd	Poinciana	34759	N	G	693	10,400		846	L	
Lake Marion Creek School	5 Second Floor	3055 Lake Marion Creek Rd	Poinciana	34759	N	G	830	12,456		847	L	
Lake Marion Creek School	6 Café	3055 Lake Marion Creek Rd	Poinciana	34759	N	G	323	4,845		442	L	
Lake Region High School	1	1995 Thunder Road	Eagle Lake	33839	R	G	0	0			S, F	
Lake Region High School	2	1995 Thunder Road	Eagle Lake	33839	R	G	318	4,768			S, F	per pbsy study- hallways
Lake Region High School	3	1995 Thunder Road	Eagle Lake	33839	R	G, A	211	3,172			S, F	per pbsy study- hallways
Lake Region High School	4	1995 Thunder Road	Eagle Lake	33839	R	G	478	7,168			S, F	per pbsy study- hallways
Lake Wales High School		1009 N 6th Street	Lake Wales	33853			0	0	235			
Lakeland High School		726 Hollingsworth Road	Lakeland	33801			0	0	448			
Lakeland Highlands MS	3	740 Lake Miriam Drive	Lakeland	33813	N	G	560	8,400		557	L	open 2006
Laurel Elementary School	1	1851 Laurel Avenue	Poinciana	34759	N	G	368	5,516		387	L	
Laurel Elementary School	6	1851 Laurel Avenue	Poinciana	34759	N	G	576	8,634		832	L	Per County
Lewis Elementary School		115 S Oak Avenue	Ft. Meade	33841			0	0	161			
Lincoln Avenue Academy	9	1330 N. Lincoln Ave	Lakeland	33805	N	G	397	5,955		445	L	open 2006
Loughman Oaks ES	7	4600 US Highway 17 92 N	Davenport	33837	N	G	339	5,084		343	L	open 2006
McKeel Academy (gym)	14	1810 W. Parker St	lakeland	33815	N	P	0	0		727	L	open 2004
McLaughlin Middle School		800 S 4th Street	Lake Wales	33853			0	0	41			
Medulla Community Center					R	G	175	3,480			HB7121	
Mulberry High School		NE Fourth Circle	Mulberry	33860			0	0	289			
Mulberry Middle School		300 SE 9th Avenue	Mulberry	33860			0	0	41			
N.E. Roberts ES (Classrms)	4	6600 Green Rd	Lakeland	33810	N	G	495	7,427		487	L	open 8/02
N.E. Roberts ES (Classrooms)	6	6600 Green Rd	Lakeland	33810	N	G	325	4,875		488	L	open 8/02
N.E. Roberts ES (Classrooms)	7	6600 Green Rd	Lakeland	33810	N	G	275	4,124		382	L	per County
N.E. Roberts ES (Dining)	2	6600 Green Rd	Lakeland	33810	N	G	296	4,447		367	L	open 8/02
O'Brien Elementary	9	1225 E. Lime St	Lakeland	33801	N	G, A	397	5,960		500	L	per County
O'Brien Elementary	10	1225 E. Lime St	Lakeland	33801	N	G	420	6,303		544	L	per County
Padgett Elementary School		110 Leelon Street	Lakeland	33809			0	0	85		L	
Palmetto Elementary School	5	315 Palmetto Street	Poinciana	34759	N	G	698	10,465		797	L	per County
Palmetto Elementary School	4 Dining	315 Palmetto Street	Poinciana	34759	N	G	348	5,227		346	L	per County
Pinewood ES	6	1400 Gilber Street	Eagle Lake	33839	N	G	316	4,746		404	L	open 2006
Polk City Elementary School		125 S Bougenville Avenue	Polk City	33868			0	0	25			
Purcell ES	3	305 First Ave NE	Mulberry	33860	N	G	414	6,211		541	L	open 2006
R.B. Wagner Elementary	2	5500 Yates Road	Lakeland	33811	N	G	298	4,477		367	L	open 8/02
R.B. Wagner Elementary	4	5500 Yates Road	Lakeland	33811	N	G	495	7,427		487	L	open 8/02
R.B. Wagner Elementary	6	5500 Yates Road	Lakeland	33811	N	G	325	4,875		487	L	open 8/02
R.B. Wagner Elementary	7	5500 Yates Road	Lakeland	33811	N	G	240	3,602		376	L	per County
Ridge Community HS (Senior)	2 First Floor	500 W Orchid Drive	Davenport	33837	N	G	995	14,922		909	L	19,140 sq ft / 957 spaces-no survey
Ridge Community HS (Senior)	2 Second Floor	500 W Orchid Drive	Davenport	33837	N	G	773	11,601		868	L	15,661 sq ft / 783 spaces- no survey
Ridge Community HS (Senior)	3 First Floor	500 W Orchid Drive	Davenport	33837	N	G	713	10,696		888	L	17,722 sq ft / 887 spaces- no survey
Ridge Community HS (Senior)	3 Second Floor	500 W Orchid Drive	Davenport	33837	N	G	737	11,062		711	L	13,680 sq ft / 684 spaces- no survey
Ridge Community HS (Senior)	5 First Floor	500 W Orchid Drive	Davenport	33837	N	G	413	6,202		405	L	8,706 sq ft / 435 spaces- no survey
Ridge Community HS (Senior)	6 (Gym)	500 W Orchid Drive	Davenport	33837	N	P	0	0		770	L	14,835 sq ft / 742 spaces-no survey
Ridgeview Global Studies Academy	2	1000 Dunson Rd.	Davenport	33837	N	G	353	5,288		374	L	S-1523-2003
Ridgeview Global Studies Academy	6	1000 Dunson Rd.	Davenport	33837	N	G	315	4,725		501	L	
Ridgeview Global Studies Academy	7	1000 Dunson Rd.	Davenport	33837	N	G	240	3,604		376	L	per County
River Ranch Chapel					R	G	208	4,160			HB7121	
Rochelle School of Arts	15 - 1st flr	1501 MLK Avenue	Lakeland	33805	N	G	469	7,039		435	L	
Rochelle School of the Arts	15-2nd flr	1501 MLK Avenue	Lakeland	33805	N	G	375	5,617		511	L	open 2006
Roosevelt Vocational		115 E Street	Lake Wales	33853			0	0	51			
Sandhill Elementary	2	1801 Tyner Road	Haines City	33844	R	G	239	3,584		374	S, L	S-1523-2003
Sandhill Elementary	6	1801 Tyner Road	Haines City	33844	N	G	380	5,703		501	L	open 2003
Sandhill Elementary	7	1801 Tyner Road	Haines City	33844	N	G	238	3,577		376	L	per County
Scott Lake ES	4	1140 E. County Road 540A	Lakeland	33813	N	G	413	6,201		432	L	open 2006
Sleepy Hill ES	3- 1st floor	2285 Sleepy Hill Road	Lakeland	33810	N	G	516	7,741		582	L	open 2006
Sleepy Hill ES	3-2nd floor	2285 Sleepy Hill Road	Lakeland	33810	N	G	555	8,325		585	L	open 2006
Sleepy Hill ES	4- 1st floor	2285 Sleepy Hill Road	Lakeland	33810	N	G	461	6,911		582	L	open 2006
Sleepy Hill ES	4-2nd floor	2285 Sleepy Hill Road	Lakeland	33810	N	G	453	6,795		585	L	open 2006
Sleepy Hill ES	5-Dining	2285 Sleepy Hill Road	Lakeland	33810	N	G	358	5,366		444	L	open 2006
Southwest ES	9	2650 Southwest Avenue	Lakeland	33803	N	G	385	5,771		425	L	open 2006
Spook Hill ES	14	321 East North Avenue	Lake Wales	33853	N	G	344	5,162		343	L	open 2006
Stambaugh Middle School	1	226 N Bartow Road	Auburndale	33823	R	G	0	0	308		S, F	not done
Stambaugh Middle School	3	226 N Bartow Road	Auburndale	33823	R	G	0	0			S, F	not done

**2012 Statewide Emergency Shelter Plan**

<b>POLK</b>												
Stambaugh Middle School	8	226 N Bartow Road	Auburndale	33823	R	G	0	0			S,F	not done
Stambaugh Middle School		226 N Bartow Road	Auburndale	33823			0	0	0			
Stephens ES	5	1350 N Maple Street	Bartow	33830	N	G	318	4,763		402	L	open 2006
Tenoroc Senior High	2-1st Floor	4905 Saddle Creek Road	Lakeland		N	G	1,016	15,237		962	L	per County
Tenoroc Senior High	2-2nd Floor	4905 Saddle Creek Road	Lakeland		N	G	908	13,623		870	L	per County
Tenoroc Senior High	3-1st floor	4905 Saddle Creek Road	Lakeland		N	G	683	10,245		742	L	per County
Tenoroc Senior High	3-2nd floor	4905 Saddle Creek Road	Lakeland		N	G	742	11,125		654	L	per County
Tenoroc Senior High	5-Dining	4905 Saddle Creek Road	Lakeland		N	G	404	6,056		437	L	per County
Tenoroc Senior High	6-Gym	4905 Saddle Creek Road	Lakeland		N	G	1,123	16,852		754	L	per County
Westwood Middle School		3520 Avenue J NW	Winter Haven	33881			0	0	271			
Winter Haven High School	20-Café	600 6th Street SE	Winter Haven	33880	N	G	449	6,736		492	L	per County
							0	0				
							0	0				
							0	0				
							0	0				
							0	0				
							0	0				
<b>TOTALS FOR POLK COUNTY</b>							<b>39,081</b>	<b>588,817</b>	<b>6,190</b>	<b>43,997</b>		<b>0</b>
Year 2012	Shelter Capacity In People	Shelter Demand In People	Surplus/Deficit In People	Shelter Capacity (ft2)			Surplus/Deficit (ft2)	Result				
Storm Category 4/5	39,081	26,570	12,511	588,817			57,417					
<b>Special Needs Storm Shelters</b>												
Name	Bldg #	Address	City	Zip			SpNS Capacity (spaces @ 60sf) (meets ARC 4496)	SpNs Capacity (sf) (meets ARC 4496)	SpNS Capacity (spaces @ 60sf) (does not meet ARC 4496)	Local Planned Usage (reported capacity)	Funding Source: Local (L), State (S), Federal (F), and Program Name	Comments
lakeland Senior Center, Bartow, Haines City Senior Centers							0	0	700	0		
McKeel Academy (gym)	14	1810 W. Parker St	Lakeland	33815	N	P	242	14,532		727	L	open 2004
Ridge Community HS (Senior)	6 (Gym)	500 W Orchid Drive	Davenport		N	P	412	16,475		1,235	L	open 2005
TBD							0	0				
							0	0				
							0	0				
							0	0				
							0	0				
							0	0				
Year 2012	SpNs Shelter Capacity In Spaces (meets ARC 4496)	SpNs Shelter Demand In Spaces	Surplus/Deficit In Spaces	SpNs Shelter Capacity (ft2)			Surplus/Deficit (ft2)	Result				
Storm Category 4/5	654	2,338	-1,684	39,240			-101,040					

**2012 Statewide Emergency Shelter Plan**

**PUTNAM**

Name	Bldg. #	Address	City	Zip	Retrofitted (R) or New Construction (N)	General (G), PSN (P), Pet-Friendly (A)	Total Risk Capacity In People (Meets ARC 4496)	Total Risk Capacity (ft <sup>2</sup> ) (Meets ARC 4496)	Risk Capacity In People (Does not Meet ARC 4496 or Not Yet Surveyed)	Local Planned Usage (reported capacity)	Funding Source: Local (L), State (S), Federal (F), and Program Name	Comments
Browning-Pearce Elementary School	4	100 Bear Boulevard	San Mateo	32187	N	G	0	0	400	325	S, L	per shelter study
Crescent City High School	1	2201 S Highway 17	Crescent City	32112		G	0	0		1,000		
Interlachen Elementary School	4	251 S State Rd 100	Interlachen	32148		G	0	0		600		
Jenkins Middle School	5	1100 N 19th Street	Palatka	32177	R	G	0	0		600	HB7121	dropped
Kelley Smith ES	6	141 Kelly Smith Road	Palatka	32177	R	G	0	0			HB7121	dropped
Middleton Burney ES	1	1020 Huntington Road	Crescent City	32112	R	G	805	16,100			HB7121	
Ochwilla Elementary School	4	299 N SR 21	Melrose	32640	N	G,A	260	3,894		325	S, L	sf per shelter study
Palatka High School	1	302 Mellon Road	Palatka	32177		G	0	0		1,000		
Price Martin Community Center	1	220 N 11th Street	Palatka	32177		G	0	0		100		
QI Roberts Middle School	2	901 SR100	Florahome	32140	N	G	193	4,321		216	L	per shelter study
QI Roberts Middle School	5	901 SR100	Florahome	32140	N	G	424	8,485		424	L	per shelter study
QI Roberts Middle School	6	901 SR100	Florahome	32140	N	G	194	4,687		234	L	per shelter study
<b>TOTALS FOR PUTNAM COUNTY</b>							<b>1,876</b>	<b>37,487</b>	<b>400</b>	<b>4,824</b>		<b>0</b>

Year 2012	Shelter Capacity In People	Shelter Demand In People	Surplus/ Deficit In People	Shelter Capacity (ft2)	Surplus/ Deficit (ft2)	Result
Storm Category 4/5	1,876	6,695	-4,819	37,487	-96,413	

**Special Needs Storm Shelters**

Name	Bldg #	Address	City	Zip			SpNS Capacity (spaces @ 60sf) (meets ARC 4496)	SpNs Capacity (sf) (meets ARC 4496)	SpNS Capacity (spaces @ 60sf) (does not meet ARC 4496)	Local Planned Usage (reported capacity)	Funding Source: Local (L), State (S), Federal (F), and Program Name	Comments
K. Smith School- New bldg TBD	12	141 Kelly Smith Road	Palatka	32177	N	P	144	8,677		144		

Year 2012	SpNs Shelter Capacity In Spaces (meets ARC 4496)	SpNs Shelter Demand In Spaces	Surplus/ Deficit In Spaces	SpNs Shelter Capacity (ft2)	Surplus/ Deficit (ft2)	Result
Storm Category 4/5	144	6	138	8,640	8,280	

**2012 Statewide Emergency Shelter Plan**

**SANTA ROSA**

Name	Bldg. #	Address	City	Zip	Retrofitted (R) or New Construction (N)	General (G), PSN (P), Pet-Friendly (A)	Total Risk Capacity In People (Meets ARC 4496)	Total Risk Capacity (ft <sup>2</sup> ) (Meets ARC 4496)	Risk Capacity In People (Does not Meet ARC 4496 or Not Yet Surveyed)	Local Planned Usage (reported capacity)	Funding Source: Local (L), State (S), Federal (F), and Program Name	Comments
Avalon Middle School	37	5445 King Arthur's Way	Milton	32583	N	G,A	352	8,855		1846	HMGp	
Avalon Middle School	37	5445 King Arthur's Way	Milton	32583	R	G,A	1,494	26,855				
Bennet C. Russel ES	all	3740 Excalibur Way	Milton	32583	N	G	7,061	141,218			L	
Chumuckla Community Center					R	G	0	0			HB7121	not used as a shelter at this time
City of Milton Community Center		5629 Byron	Milton	32570	N	G	383	7,040			S-1543A	May be used as both Spns and General during small incidents
Dixon Intermediate School	33	5540 Education Road	Pace	32571	R	G	2,193	37,469			HMGp	
Navarre HS	3 wings				R	G	1,444	28,880			S-1496-2009	
Thomas L. Sims Middle School	31	5500 Education Drive	Pace	32571	R	G	0	0			HMGp	Used for either overflow Spns or general depending on stituation
<b>TOTALS FOR SANTA ROSA COUNTY</b>							<b>12,927</b>	<b>250,317</b>	<b>0</b>	<b>1,846</b>		<b>0</b>

Year 2012	Shelter Capacity In People	Shelter Demand In People	Surplus/Deficit In People	Shelter Capacity (ft2)	Surplus/Deficit (ft2)	Result
Storm Category 4/5	12,927	6,685	6,242	250,317	116,617	

**Special Needs Storm Shelters**

Name	Bldg #	Address	City	Zip			SpNS Capacity (spaces @ 60sf) (meets ARC 4496)	SpNs Capacity (sf) (meets ARC 4496)	SpNS Capacity (spaces @ 60sf) (does not meet ARC 4496)	Local Planned Usage (reported capacity)	Funding Source: Local (L), State (S), Federal (F), and Program Name	Comments
Sims MS	31	5500 Education Drive	Pace	32571	R	P	704	42,262		351		
Milton Comm. Ctr - NOT USED		5629 Byron	Milton	32570	N	P	0	0				

Year 2012	SpNs Shelter Capacity In Spaces (meets ARC 4496)	SpNs Shelter Demand In Spaces	Surplus/Deficit In Spaces	SpNs Shelter Capacity (ft2)	Surplus/Deficit (ft2)	Result
Storm Category 4/5	704	51	653	42,240	39,180	



2012 Statewide Emergency Shelter Plan

SARASOTA												
Name	Bldg. #	Address	City	Zip	Retro fitted (R) or New Construction (N)	General (G), PSN (P), Pet-Friendly (A)	Total Risk Capacity In People (Meets ARC 4496)	Total Risk Capacity (ft <sup>2</sup> ) (Meets ARC 4496)	Risk Capacity In People (Does not Meet ARC 4496 or Not Yet Surveyed)	Local Planned Usage (reported capacity)	Funding Source: Local (L), State (S), Federal (F), and Program Name	Comments
Alta Vista ES		1050 South Euclid Avenue	Sarasota	34237			0	0	0	0		
ARC Chapter		2001 Cantu Court	Sarasota	34232	R		0	0	200			for sheltering responders
Ashton Elementary School	1	5101 Aston Road	Sarasota	34223	R	G	0	0		966	L	per report open span/ unreinf. 2002/2004 reroof designed for 130mph
Ashton Elementary School	2	5101 Aston Road	Sarasota	34223	R	G	0	0		622	L	no report on this bldg circa 2003,
Atwater Elementary School	1	4701 Huntsville Ave	North Port	34288	N	G	0	0		3,434	L	10.2' SLOSH
Bishop Niven	Dome A	4380 Fruitville Road	Sarasota	342436	N/R		415	8,300		415	F-PDM	confirmed 2005
Bishop Niven	Dome B	4380 Fruitville Road	Sarasota	342436	N/R		524	10,480		524	F-PDM	confirmed 2006
Bishop Niven	Dome E	4380 Fruitville Road	Sarasota	342436	N/R		172	3,440		172	F-PDM	confirmed 2007
Bishop Niven	Dome F	4380 Fruitville Road	Sarasota	342436	N/R		302	6,040		302	F-PDM	confirmed 2008
Booker High School		3201 N Orange Avenue	Sarasota	34234			0	0	460	0		
Booker Middle School	6	2250 Myrtle Street	Sarasota	34234	R	G	475	7,180		0	s-1435A-2003	
Booker Middle School	7	2250 Myrtle Street	Sarasota	34234	R	G	355	6,130		355	s-1435A-2003	circa 2002
Booker Middle School	14	2250 Myrtle Street	Sarasota	34234	N	G	1,062	21,240		1,062		Built 2004
Brentwood Elementary School	2	2500 Vinson Ave	Sarasota		N	G	0	0		1,125	L	1.1' SLOSH
Brookside Middle School	5	3636 S Shade Avenue	Sarasota	34293		G	435	7,913	0	435		circa 2003
Brookside Middle School	9	3636 S Shade Avenue	Sarasota	34293		G	351	7,020		351		
Brookside Middle School	3 north	3636 S Shade Avenue	Sarasota	34293		G	0	0		0		
Brookside Middle School	3 south	3636 S Shade Avenue	Sarasota	34293		G	0	0	462	462		no information
Brookside Middle School	6(Gym)	3636 S Shade Avenue	Sarasota	34293		G,A	0	0		0		locker rooms used for pets
Brookside Middle School (2000 construction)	4	3636 S Shade Avenue	Sarasota	34293	R	G	1,076	23,033		1,076	L	
Cranberry Elementary	1	2775 Shallimar Terrace	North Port	34286	N	P	0	0		1,047	S, F	SpNS see below, 10' SLOSH
Emma Booker Elementary School	1,3,4,5,6,8	2350 MLK Jr. Way	Sarasota	34234		G	0	0	0	0		
Fruitville Elementary School	9	601 Honore Avenue	Sarasota	34232			0	0	381	381		bldg 9 2004
Garden Elementary School	1	700 Center Road	Venice	34293	R	G	0	0	750	0	L	questions on unreinforced walls and open spans 9.1' SLOSH
Garden Elementary School	4(Café)	700 Center Road	Venice	34293	R	G	0	0		0		9.1' SLOSH
Glennallen Elementary	7	7050 Glenallen Boulevard	North Port	34287	R	G	0	0		540		9.1' SLOSH
Glennallen Elementary	8	7050 Glenallen Boulevard	North Port	34287	R	G	0	0		461		9.1' SLOSH
Glennallen Elementary	#1, Sec 400	7050 Glenallen Boulevard	North Port	34287	R	G	0	0		0	HMGP	Researching Retro Records 9.1' SLOSH
Glennallen Elementary	#1, Sec300	7050 Glenallen Boulevard	North Port	34287	R	G	0	0		0	HMGP	Researching Retro Records 9.1' SLOSH
Gocio Elementary School	3	3450 Gocio Road	Sarasota	34235	R	G	0	0		0		
Gocio Elementary School	5	3450 Gocio Road	Sarasota	34235	R	G	0	0		0		
Gulf Gate Elementary School	1	6500 Lockwood Ridge Rd	Sarasota	34231	N	G	0	0		2,933	L	5.5' SLOSH
Heron Creek Middle School	3	6501 W. Price	North Port	34287	N	G	0	0		1,353		9.2' SLOSH
Heron Creek Middle School	4	6501 W. Price	North Port	34287	N	G	0	0		1,243		9.2' SLOSH
Heron Creek Middle School	5	6501 W. Price	North Port	34287	N	G	0	0		469		9.2' SLOSH
Heron Creek Middle School	6	6501 W. Price	North Port	34287	N	G,A	0	0		0		9.2' SLOSH
Heron Creek Middle School	7	6501 W. Price	North Port	34287	N	G	0	0		0		9.2' SLOSH
Heron Creek Middle School	10	6501 W. Price	North Port	34287	N	G	0	0		482		9.2' SLOSH
Lakeview Elementary School	#1, Sec 300	7299 Proctor Road	Sarasota	34241	R	G	428	8,547		432	s-1543	
Lakeview Elementary School	#1, Sec 400	7299 Proctor Road	Sarasota	34241	R	G	404	8,078		406	s-1543	
Lakeview Elementary School	#1, Sec 500	7299 Proctor Road	Sarasota	34241	R	G	397	7,949		393	s-1543	
Lamarque Elementary School	1	3415 Lamarque Avenue	North Port	34286	N	P	0	0		1,275	L	SpNS see below, 9.5' SLOSH
Laurel Middle School	4	1900 East Laurel Road	Laurel	34275	R	G	0	0	1,202	0		17.7' SLOSH
Laurel Middle School	6	1900 East Laurel Road	Laurel	34275	R	G	0	0		0		17.7' SLOSH
Laurel Middle School	3 (Café)	1900 East Laurel Road	Laurel	34275	R	G	0	0		0		17.7' SLOSH
Laurel Middle School	5(Gym)	1900 East Laurel Road	Laurel	34275	R	G	0	0		0		17.7' SLOSH
McIntosh Middle School		701 S McIntosh Road	Sarasota	34232			0	0	500			5.5' SLOSH
North Porth High School	2	6400 West Price Blvd	North Port	34287	N	G	0	0		0		8.7' SLOSH
North Porth High School	3	6400 West Price Blvd	North Port	34287	N	G,A	0	0		1,009		8.7' SLOSH
North Porth High School	4	6400 West Price Blvd	North Port	34287	N	G	0	0		746	L	8.7' SLOSH

2012 Statewide Emergency Shelter Plan

SARASOTA

Name	Bldg. #	Address	City	Zip	Retro fitted (R) or New Construction (N)	General (G), PSN (P), Pet-Friendly (A)	Total Risk Capacity In People (Meets ARC 4496)	Total Risk Capacity (ft <sup>2</sup> ) (Meets ARC 4496)	Risk Capacity In People (Does not Meet ARC 4496 or Not Yet Surveyed)	Local Planned Usage (reported capacity)	Funding Source: Local (L), State (S), Federal (F), and Program Name	Comments
North Porth High School	5	6400 West Price Blvd	North Port	34287	N	G	0	0		769		8.7' SLOSH
North Porth High School	6	6400 West Price Blvd	North Port	34287	N	G	0	0		0	L	8.7' SLOSH
North Porth High School	7	6400 West Price Blvd	North Port	34287	N	G	0	0		779		8.7' SLOSH
North Porth High School	8	6400 West Price Blvd	North Port	34287	N	G	0	0		869		8.7' SLOSH
Oak Park School	4	7285 Proctor Road	Sarasota	34241	R	P	0	0			HMGP	Post Storm only due to roof
Oak Park School	2A	7285 Proctor Road	Sarasota	34241	R	P	0	0	1,597		HMGP	Post Storm only due to roof
Oak Park School	2B	7285 Proctor Road	Sarasota	34241	R	P	0	0			HMGP	Post Storm only due to roof
Oak Park School	3A	7285 Proctor Road	Sarasota	34241	R	P	0	0			HMGP	Post Storm only due to roof
Oak Park School	3B	7285 Proctor Road	Sarasota	34241	R	P	0	0			HMGP	Post Storm only due to roof
Philippi Shores	2	4747 S. Tamiami Trail	Sarasota	34231	N	G	0	0		1,835	L	1.5' SLOSH
Phoenix School	1	1085 S. Shade Ave	Sarasota	34237	N	G	0	0	664	664		2.7' SLOSH
Pineview School	1	501 Old Venice Road	Osprey	34229	R	G	0	0		330	S-1543	5.1' SLOSH
Pineview School	2	501 Old Venice Road	Osprey	34229	R	G	0	0		269	S-1543	5.1' SLOSH
Pineview School	3	501 Old Venice Road	Osprey	34229	R	G	0	0			F	5.1' SLOSH
Pineview School	4	501 Old Venice Road	Osprey	34229	R	G	0	0			F	5.1' SLOSH
Pineview School	5	501 Old Venice Road	Osprey	34229	R	G,A	0	0		0		5.1' SLOSH
Pineview School	8	501 Old Venice Road	Osprey	34229	R	G	0	0			F	5.1' SLOSH
Pineview School	10	501 Old Venice Road	Osprey	34229	R	G	0	0			F	5.1' SLOSH
Pineview School	11	501 Old Venice Road	Osprey	34229	R	G	0	0		331	S-1543	5.1' SLOSH
Pineview School	12	501 Old Venice Road	Osprey	34229	R	G	0	0			F	5.1' SLOSH
Pineview School	16	501 Old Venice Road	Osprey	34229	N	G	0	0		933		5.1' SLOSH
Riverview High School	2,3,5,6	One Ram Way	Sarasota	34231	N	G,A	0	0		2,574	L	8.5' SLOSH
Sarasota County Technical Center		4748 Beneva Road	Sarasota	34233			0	0	300			
Sarasota High School	13	1000 South School Avenue	Sarasota	34237	N/R	G	0	0		2,387	HMGP	10.7' SLOSH
Sarasota High School	14	1000 South School Avenue	Sarasota	34237	N/R	G	0	0		2,272	HMGP	10.7' SLOSH
Sarasota Middle School	4	4826 Ashton Road	Sarasota	34233	R	G	207	3,893		207	S-1543	
Sarasota Middle School	6	4826 Ashton Road	Sarasota	34233	R	G	330	7,468		330	S-1543	
Sarasota Middle School	7	4826 Ashton Road	Sarasota	34233	R	G	306	4,793		306	S-1543	
Sarasota Middle School	8	4826 Ashton Road	Sarasota	34233			0	0				
Sarasota Middle School	9	4826 Ashton Road	Sarasota	34233			0	0				
Sarasota Middle School	10 & 11	4826 Ashton Road	Sarasota	34233			0	0				
Sarasota Middle School	3 & 5	4826 Ashton Road	Sarasota	34233			0	0		0		
Southside Elementary	4	1901 Webber	Sarasota	34239	N	G	0	0		1,346	L	2005, 3.6' SLOSH
Suncoast Polytechnical HS	1	4650 Beneva Road	Sarasota	34233	N	G	881	17,628				
Tatum Ridge Elementary	1	4100 Tatum Road	Sarasota	34240	N	P	0	0		1,091	I	SpNS see below
Taylor Ranch Elementary School	1	2500 Taylor Ranch Road	Venice	34293	R	G	0	0			F	8' SLOSH
Taylor Ranch Elementary School	3	2500 Taylor Ranch Road	Venice	34293			0	0		0		8' SLOSH
Taylor Ranch Elementary School	4	2500 Taylor Ranch Road	Venice	34293	R	G	0	0			F	8' SLOSH
Taylor Ranch Elementary School	5	2500 Taylor Ranch Road	Venice	34293	R	G	0	0		249	S-1543	8' SLOSH
Taylor Ranch Elementary School	6	2500 Taylor Ranch Road	Venice	34293	R	G	0	0		523	S-1543	8' SLOSH
Taylor Ranch Elementary School	8	2500 Taylor Ranch Road	Venice	34293		G	0	0	476	476		8' SLOSH
Toledo Blade ES	1	1201 Geranium Avenue	North Port	34287	R	G	0	0		308	S-1523	6.5' SLOSH
Toledo Blade ES	3	1201 Geranium Avenue	North Port	34287	R	G	0	0		235	S-1523	6.5' SLOSH
Toledo Blade ES	4	1201 Geranium Avenue	North Port	34287	R	G	0	0		293	S-1523	6.5' SLOSH
Toledo Blade ES	5	1201 Geranium Avenue	North Port	34287	R	G	0	0		288	S-1523	6.5' SLOSH
Toledo Blade ES	6	1201 Geranium Avenue	North Port	34287	R	G	0	0		519	S-1523	6.5' SLOSH
Toledo Blade ES	10	1201 Geranium Avenue	North Port	34287	R	G	0	0		296	S-1523	6.5' SLOSH
Tuttle Elementary School	3	925 N Brink Avenue	Sarasota	34237			0	0	0	0		
Tuttle Elementary School	1&2	925 N Brink Avenue	Sarasota	34237	N/R	G	1,817	27,255		1,883	L	
Venice Area Middle School	1 & 6	1900 Center Road	Venice	34293			0	0	600			16.8' SLOSH
Venice Community Center	1	326 Nokomis Ave South	Venice		R	G	0	0		922	L	per county, 6.7' SLOSH
Venice Elementary - 8/1/05	1	150 Miami Ave East	Venice	34285	N	G	0	0		0	L	not an EHPA 2005, 12' SLOSH
Wilkinson Elementary School 8/1/05	6	3400 Wilkinson Road	Sarasota	34231	N	G	822	20,551		765		2005- Planned for use as Alt EOC
Woodlands Middle School	3	2700 Panacea Blvd	North Port	34289	N	G	0	0		239	L	completed 2009, 8.2' SLOSH

**2012 Statewide Emergency Shelter Plan**

**SARASOTA**

Name	Bldg. #	Address	City	Zip	Retro fitted (R) or New Construction (N)	General (G), PSN (P), Pet-Friendly (A)	Total Risk Capacity In People (Meets ARC 4496)	Total Risk Capacity (ft <sup>2</sup> ) (Meets ARC 4496)	Risk Capacity In People (Does not Meet ARC 4496 or Not Yet Surveyed)	Local Planned Usage (reported capacity)	Funding Source: Local (L), State (S), Federal (F), and Program Name	Comments
Woodlands Middle School	4	2700 Panacea Blvd	North Port	34289	N	G	0	0		1,125	L	completed 2009
Woodlands Middle School	5	2700 Panacea Blvd	North Port	34289	N	G,A	0	0		476	L	completed 2009
<b>Totals for Sarasota County</b>							<b>10,759</b>	<b>206,938</b>	<b>7,592</b>	<b>50,560</b>		
Year 2012	Shelter Capacity In People	Shelter Demand In People	Surplus/ Deficit In People	Shelter Capacity (ft2)			Surplus/ Deficit (ft2)	Result				
Storm Category 4/5	10,759	28,209	-17,450	206,938			-357,242					
<b>Special Needs Storm Shelters</b>												
Name	Bldg #	Address	City	Zip			SpNs Capacity (spaces @ 60sf) (meets ARC 4496)	SpNs Capacity (sf) (meets ARC 4496)	SpNs Capacity (spaces @ 60sf) (does not meet ARC 4496)	LOCAL PLANNED USAGE	Funding Source: Local (L), State (S), Federal (F), and Program Name	Comments
Oak Park School (marginal, 2nd Tier)		7285 Proctor Road	Sarasota	34241	R	P	525	31,500		525		no surge
Cranberry Elementary	1	2775 Shallimar Terrace	North Port	34286	N	P	0	0		1,047	L	2005, county provided capacity, 10' SLOSH
Tatum Ridge ES	1	4100 Tatum Ridge RD	Sarasota	34240	N	P	1,091	65,460		1,091		county provided capacity- ready Sept 2006
LaMarque Elementary (Elementary H)	1	3415 Lamarque Ave	North Port	34286	N	P	0	0		1,275		county provided capacity- ready Sept 2006, surge issues
Year 2012	SpNs Shelter Capacity In Spaces (meets ARC 4496)	SpNs Shelter Demand In Spaces	Surplus/ Deficit In Spaces	SpNs Shelter Capacity (ft2)			Surplus/ Deficit (ft2)	Result				
Storm Category 4/5	1,616	3,076	-1,460	96,960			-87,600					

## 2012 Statewide Emergency Shelter Plan

## Exiting Storms

## SARASOTA

Name	Bldg. #	Address	City	Zip	Retro fitted (R) or New Construction (N)	General (G), PSN (P), Pet - Friendly (A)	Total Risk Capacity In People (Meets ARC 4496)	Total Risk Capacity (ft <sup>2</sup> ) (Meets ARC 4496)	Risk Capacity In People (Does not Meet ARC 4496 or Not Yet Surveyed)	Local Planned Usage (reported capacity)	Funding Source: Local (L), State (S), Federal (F), and Program Name	Comments
Atwater Elementary School	1	4701 Huntsville Ave	North Port	34288	N	G	3,434	68,680		3,434	L	Exiting
Brentwood Elementary School	2	2500 Vinson Ave	Sarasota		N	G	1,125	22,500		1,125	L	Exiting
Cranberry Elementary	1	2775 Shallimar Terrace	North Port	34286	N	P	0	0		1,047	S, F	Exiting
Garden Elementary School	4(Café)	700 Center Road	Venice	34293	R	G	0	0		0		Exiting
Glennallen Elementary	7	7050 Glennallen Boulevard	North Port	34287	R	G	540	10,800		540		Exiting
Glennallen Elementary	8	7050 Glennallen Boulevard	North Port	34287	R	G	461	9,220		461		Exiting
Glennallen Elementary	#1, Sec 400	7050 Glennallen Boulevard	North Port	34287	R	G	428	8,078		0	HMGP	Exiting
Glennallen Elementary	#1, Sec300	7050 Glennallen Boulevard	North Port	34287	R	G	428	8,547		0	HMGP	Exiting
Gulf Gate Elementary School	1	6500 Lockwood Ridge Rd	Sarasota	34231	N	G	2,933	58,660		2,933	L	Exiting
Heron Creek Middle School	3	6501 W. Price	North Port	34287	N	G	1,353	27,060		1,353		Exiting
Heron Creek Middle School	4	6501 W. Price	North Port	34287	N	G	1,243	24,860		1,243		Exiting
Heron Creek Middle School	5	6501 W. Price	North Port	34287	N	A	469	9,380		469		Exiting
Heron Creek Middle School	6	6501 W. Price	North Port	34287	N	G/A	0	0		0		Exiting
Heron Creek Middle School	7	6501 W. Price	North Port	34287	N	G	0	0		0		Exiting
Heron Creek Middle School	10	6501 W. Price	North Port	34287	N	G	482	9,640		482		Exiting
Lamarque Elementary School	1	3415 Lamarque Avenue	North Port	34286	N	P	0	0		1,275	L	Exiting
Laurel Middle School	4	1900 East Laurel Road	Laurel	34275	R	G	0	0	1,202	0		SLOSH Issue
Laurel Middle School	6	1900 East Laurel Road	Laurel	34275	R	G	0	0		0		SLOSH Issue
Laurel Middle School	3 (Café)	1900 East Laurel Road	Laurel	34275	R	G	0	0		0		SLOSH Issue
Laurel Middle School	5(Gym)	1900 East Laurel Road	Laurel	34275	R	G	0	0		0		SLOSH Issue
McIntosh Middle School		701 S McIntosh Road	Sarasota	34232			0	0	500			Exiting
North Porth High School	2	6400 West Price Blvd	North Port	34287	N	G	0	0		0		Exiting
North Porth High School	3	6400 West Price Blvd	North Port	34287	N	G/A	1,009	20,180		1,009		Exiting
North Porth High School	4	6400 West Price Blvd	North Port	34287	N	G	746	14,920		746	L	Exiting
North Porth High School	5	6400 West Price Blvd	North Port	34287	N	G	769	15,380		769		Exiting
North Porth High School	6	6400 West Price Blvd	North Port	34287	N	G	0	0		0	L	Exiting
North Porth High School	7	6400 West Price Blvd	North Port	34287	N	G	779	15,580		779		Exiting
North Porth High School	8	6400 West Price Blvd	North Port	34287	N	G	869	17,380		869		Exiting
Philippi Shores	2	4747 S. Tamiami Trail	Sarasota	34231	N	G	1,835	36,700		1,835	L	Exiting
Phoenix School	1	1085 S. Shade Ave	Sarasota	34237	N		0	0	664	664		Exiting
Pineview School	1	501 Old Venice Road	Osprey	34229	R	G	245	3,675		330	S-1543	Exiting
Pineview School	2	501 Old Venice Road	Osprey	34229	R	G	248	3,714		269	S-1543	Exiting
Pineview School	3	501 Old Venice Road	Osprey	34229	R	G	0	0			F	Exiting
Pineview School	4	501 Old Venice Road	Osprey	34229	R	G	0	0			F	Exiting
Pineview School	5	501 Old Venice Road	Osprey	34229	R	G/A	26	250		0		Exiting
Pineview School	8	501 Old Venice Road	Osprey	34229	R	G	0	0			F	Exiting
Pineview School	10	501 Old Venice Road	Osprey	34229	R	G	0	0			F	Exiting
Pineview School	11	501 Old Venice Road	Osprey	34229	R	G	331	6,282		331	S-1543	Exiting
Pineview School	12	501 Old Venice Road	Osprey	34229	R	G	0	0			F	Exiting
Pineview School	16	501 Old Venice Road	Osprey	34229	N	G	1,101	22,020		933		Exiting
Riverview High School	2,3,5,6	One Ram Way	Sarasota	34231	N	G	2,574	51,480		2,574	L	Exiting
Sarasota High School	13	1000 South School Avenue	Sarasota	34237	N/R	G	2,387	40,719		2,387	HMGP	Exiting
Sarasota High School	14	1000 South School Avenue	Sarasota	34237	N/R	G	2,272	42,200		2,272	HMGP	Exiting
Southside Elementary	4	1901 Webber	Sarasota	34239	N	G	1,346	23,748		1,346	L	Exiting
Taylor Ranch Elementary School	1	2500 Taylor Ranch Road	Venice	34293	R	G	0	0			F	Exiting
Taylor Ranch Elementary School	3	2500 Taylor Ranch Road	Venice	34293			0	0		0		Exiting
Taylor Ranch Elementary School	4	2500 Taylor Ranch Road	Venice	34293	R	G	0	0			F	Exiting
Taylor Ranch Elementary School	5	2500 Taylor Ranch Road	Venice	34293	R	G	249	6,027		249	S-1543	Exiting
Taylor Ranch Elementary School	6	2500 Taylor Ranch Road	Venice	34293	R	G	490	7,355		523	S-1543	Exiting
Taylor Ranch Elementary School	8	2500 Taylor Ranch Road	Venice	34293			0	0	476	476		Exiting
Toledo Blade ES	1	1201 Geranium Avenue	North Port	34287	R	G	308	4,992		308	S-1523	Exiting
Toledo Blade ES	3	1201 Geranium Avenue	North Port	34287	R	G	152	2,280		235	S-1523	Exiting
Toledo Blade ES	4	1201 Geranium Avenue	North Port	34287	R	G	246	3,690		293	S-1523	Exiting
Toledo Blade ES	5	1201 Geranium Avenue	North Port	34287	R	G	293	7,314		288	S-1523	Exiting
Toledo Blade ES	6	1201 Geranium Avenue	North Port	34287	R	G	430	6,452		519	S-1523	Exiting
Toledo Blade ES	10	1201 Geranium Avenue	North Port	34287	R	G	291	4,358		296	S-1523	Exiting
Venice Area Middle School	1 & 6	1900 Center Road	Venice	34293			0	0	600			SLOSH Issue

**2012 Statewide Emergency Shelter Plan  
Exiting Storms**

**SARASOTA**

Name	Bldg. #	Address	City	Zip	Retro fitted (R) or New Construction (N)	General (G), PSN (P), Pet - Friendly (A)	Total Risk Capacity In People <i>(Meets ARC 4496)</i>	Total Risk Capacity (ft <sup>2</sup> ) <i>(Meets ARC 4496)</i>	Risk Capacity In People <i>(Does not Meet ARC 4496 or Not Yet Surveyed)</i>	Local Planned Usage (reported capacity)	Funding Source: Local (L), State (S), Federal (F), and Program Name	Comments
Venice Community Center	1	326 Nokomis Ave South	Venice		R	G	922	18,440		922	L	Exiting
Venice Elementary - 8/1/05	1	150 Miami Ave East	Venice	34285	N	G	0	0		0	L	Exiting
Woodlands Middle School	3	2700 Panacea Blvd	North Port	34289	N	G	239	4,700		239	L	Exiting
Woodlands Middle School	4	2700 Panacea Blvd	North Port	34289	N	G	1,125	22,500		1,125	L	Exiting
Woodlands Middle School	5	2700 Panacea Blvd	North Port	34289	N	G	476	9,520		476	L	Exiting
<b>Totals for Sarasota County</b>							<b>45,413</b>	<b>876,219</b>	<b>7,592</b>	<b>50,560</b>		
Year 2012	Shelter Capacity In People	Shelter Demand In People	Surplus/ Deficit In People	Shelter Capacity (ft2)			Surplus/ Deficit (ft2)	Result				
Storm Category 4/5	45,413	28,209	17,204	876,219			312,039					
<b>Special Needs Storm Shelters</b>												
Name	Bldg #	Address	City	Zip			SpNS Capacity (spaces @ 60sf) (meets ARC 4496)	SpNs Capacity (sf) (meets ARC 4496)	SpNS Capacity (spaces @ 60sf) (does not meet ARC 4496)	LOCAL PLANNED USAGE	Funding Source: Local (L), State (S), Federal (F), and Program Name	Comments
Cranberry Elementary	1	2775 Shallimar Terrace	North Port	34286	N	P	1,047	62,840		1,047	L	Exiting
LaMarque Elementary (Elementary H)	1	3415 Lamarque Ave	North Port	34286	N	P	1,275	76,500		1,275		Exiting
Year 2012	SpNs Shelter Capacity In Spaces (meets ARC 4496)	SpNs Shelter Demand In Spaces	Surplus/ Deficit In Spaces	SpNs Shelter Capacity (ft2)			Surplus/ Deficit (ft2)	Result				
Storm Category 4/5	3,938	3,076	862	236,280			51,720					

**2012 Statewide Emergency Shelter Plan**

<b>SEMINOLE</b>												
Name	Bldg. #	Address	City	Zip	Retrofitted (R) or New Construction (N)	General (G), PSN (P), Pet-Friendly (A)	Total Risk Capacity In People (Meets ARC 4496)	Total Risk Capacity (ft <sup>2</sup> ) (Meets ARC 4496)	Risk Capacity In People (Does not Meet ARC 4496 or Not Yet Surveyed)	Local Planned Usage (reported capacity)	Funding Source: Local (L), State (S), Federal (F), and Program Name	Comments
Bentley ES	1 (Excluding Spns area)	2190 Oregon Avenue	Sanford	32771	R	P, A	172	3,435			S-1435A-2003	SpNS see below
Crystal Lakes ES	1	231 Rinehart Road	Lake Mary	32746	N	G	500	10,000		500	L	
English Estates Elementary School - Bldg 100	100	299 Oxford Road	Fern Park	32370	R	G	1,000	17,300		1,000	HMGP	lrdm confirmed
Geneva Elementary School - Bldg 4	4	275 1st Street	Geneva	32372	R	G	193	2,900		275	HMGP	lrdm confirmed
Highlands Elementary School	1 (excluding Spns area)	1600 Shepard Road	Winter Springs	32708	R	G	743	14,852		212	S-1118A	lrdm confirmed
John Evans Elementary	1	141 Academy Drive	Oviedo	32765	R	G	838	20,960		424	HMGP	lrdm confirmed
Lake Brantley High School	6	991 Sand Lake Road	Altamonte Springs	32714	R	G	667	13,414		666	S-1588-2006	
Lake Brantley High School	7	991 Sand Lake Road	Altamonte Springs	32714	R	G	741	18,534		666	S-1588-2006	
Lake Brantley High School	8	991 Sand Lake Road	Altamonte Springs	32714	R	G	667	16,034		668	S-1588-2006	retrofit done 8/07
Lake Mary High School	Gym/Café/1st floor hallways	655 Longwood/Lake Mary R	Lake Mary	32746	R	G	1,810	45,239		1,200	S-1118A	lrdm confirmed-first floor
Lawton Chiles MSI	4 (Music/gym)/5 (gym)	3225 Lockwood Boulevard	Oviedo	32765	R	G	750	15,286		750	S-1523	lrdm confirmed
Layer ES	bldg 1 (excluding Café)	SR 419	Winter Springs	32708	R	G	2,018	40,368		100	S-1588-2006	SpNS see below- retrofit done 8/07
Lyman High School	7	865 CR 427 South	Longwood	32750	R	G,A	993	14,891		1,500	HMGP	lrdm confirmed
Midway ES	1	2251 Jitway	Sanford	32771	N	G	500	10,000		500	L	online 2010
Millenium MS	3 (Café)	21 lakeview Drive	Sanford	32773	R	G	219	4,372		650	HMGP	arc4496 form
Millenium MS	5 (Classrooms & Hallways-1st floor)	21 lakeview Drive	Sanford	32773	R	G	1,234	24,674			HMGP	arc4496 form
Walker ES	Café	3101 Snowhill	Chuluota	32766	R	G	375	7,500		400	S-1588-2006	retrofit done 8/07
Winter Springs High School	4	130 Tuskawilla Road	Winter Springs	32708	R	G	719	17,964		440	S-1588-2006	retrofit done 8/07
Winter Springs High School	5 (1st floor only)	130 Tuskawilla Road	Winter Springs	32708	R	G	565	8,331			S-1467-2004	retrofit completed
Winter Springs High School	6 (1st floor only)	130 Tuskawilla Road	Winter Springs	32708	R	G	522	7,834			S-1467-2004	retrofit completed
Winter Springs High School	7 (1st floor only)	130 Tuskawilla Road	Winter Springs	32708	R	G	367	5,510			S-1467-2004	retrofit completed
<b>TOTALS FOR SEMINOLE COUNTY</b>							<b>15,593</b>	<b>319,398</b>	<b>0</b>	<b>9,951</b>		<b>0</b>
<b>Year 2012</b>	<b>Shelter Capacity In People</b>	<b>Shelter Demand In People</b>	<b>Surplus/ Deficit In People</b>	<b>Shelter Capacity (ft2)</b>			<b>Surplus/ Deficit (ft2)</b>	<b>Result</b>				
Storm Category 4/5	15,593	10,332	5,261	319,398			112,758					
<b>Special Needs Storm Shelters</b>												
Name	Bldg #	Address	City	Zip	R	P, A	SpNS Capacity (spaces @ 60sf) (meets ARC 4496)	SpNs Capacity (sf) (meets ARC 4496)	SpNS Capacity (spaces @ 60sf) (does not meet ARC 4496)	Local Planned Usage (reported capacity)	Funding Source: Local (L), State (S), Federal (F), and Program Name	Comments
Bentley ES	1 (1st floor only-shuttered)	2190 Oregon Avenue	Sanford	32771	R	P, A	100	8,479		100		
Highlands ES	1 (1st floor only-shuttered)	1600 Shepard Road	Winter Springs	32708	R	P	100	8,479		100		
Layer ES	Café	SR 419	Winter Springs	32708	R	P	100	7,500		100		
							0	0				
							0	0				
							0	0				
<b>Year 2012</b>	<b>SpNs Shelter Capacity In Spaces (meets ARC 4496)</b>	<b>SpNs Shelter Demand In Spaces</b>	<b>Surplus/ Deficit In Spaces</b>	<b>SpNs Shelter Capacity (ft2)</b>			<b>Surplus/ Deficit (ft2)</b>	<b>Result</b>				
Storm Category 4/5	300	19	281	18,000			16,860					

**2012 Statewide Emergency Shelter Plan**

**ST. JOHNS**

Name	Bldg. #	Address	City	Zip	Retrofitted (R) or New Construction (N)	General (G), PSN (P), Pet - Friendly (A)	Total Risk Capacity In People <small>(Meets ARC 4496)</small>	Total Risk Capacity (ft <sup>2</sup> ) <small>(Meets ARC 4496)</small>	Risk Capacity In People <small>(Does not Meet ARC 4496 or Not Yet Surveyed)</small>	Local Planned Usage (reported capacity)	Funding Source: Local (L), State (S), Federal (F), and Program Name	Comments
Allen Nease HS		10550 Ray Road	St. Augustine	32081			0	0	800	800		
Bartram Trail High School	4-Gym	2050 Roberts Road	St. Johns	32259	N	G	1,098	27,455	0	500	L	
Creekside High		100 Knights Lane	St. Johns	32259			0	0		500		
Cunningham Creek Elementary School	2,3,4	1205 Roberts Road	St. Johns	32259	R	G	1,200	20,788	0	800	HMGP	
Durbin Creek Elementary	1	4100 Race Track Road	St. Johns	32259	N	G	1,788	44,688		500	L	
Durbin Creek Elementary	2	4101 Race Track Road	St. Johns	32259	R	G	252	5,040			S-1621X	
Fruit Cove Middles School	Gym	2680 Race Track Road	St. Johns	32259	N	G	1,122	28,060		500	L	area per ARMOR- 800 section
Gamble Rogers Middle School		6250 US 1 South	St. Augustine	32086			0	0	0	800		16.86' SLOSH
Hartley Elementary School		260 Cacique Drive	St. Augustine	32086			0	0	335	335		
Hickory Creek ES		235 Hickory Creek Trail	St. Johns	32259	N	G	500	10,000		500	L	
Julington Creek Elementary		2316 Racetrack Road	St. Johns	32259			0	0	600	600		
Mill Creek Elementary School	2,3,4	3750 International golf Pkwy	St. Augustine	32092	R	G	1,200	20,202	0	800	HMGP	
Murray Middle School		150 N. Holmes Blvd	St. Augustine	32084			0	0	189	189		
Osceola Elementary School	2,4	1605 Osceola Elementary	St. Augustine	32084	R	G	0	0	0	800	HMGP	12.3' SLOSH
Otis Mason Elementary School	2,3,4	SR 207 & I-95	St. Augustine	32086	R	G	1,200	19,926	0	800	HMGP	
Pedro Menendez High School	4-Gym	600 SR-206 West	St. Augustine	32086	N	G	1,233	30,823	0	500	L	
Sebastian Middle School		2955 Lewis Speedway	St. Augustine	32084			0	0	800	800		13.75' SLOSH
South Woods ES	1	4750 SR 206 West	Elkton	32033	N	G,A	500	10,000		500	L	
St. Augustine High School		3205 Varella Avenue	St. Augustine	32084			0	0	800	800		8.94' SLOSH
Switzerland Point Middle		777 Greenbriar Road	St. Johns	32259			0	0		800		
Timberlin Creek ES	1	555 Pine Tree Lane	St. Augustine	32092	N	G,A	500	10,000		500	L	
Webster Elementary		420 North Orange Street	St. Augustine	32084			0	0	80	80		
<b>TOTALS FOR ST. JOHNS COUNTY</b>							<b>10,593</b>	<b>226,982</b>	<b>3,604</b>	<b>12,404</b>		<b>0</b>

Year 2012	Shelter Capacity In People	Shelter Demand In People	Surplus/ Deficit In People	Shelter Capacity (ft2)	Surplus/ Deficit (ft2)	Result
Storm Category 4/5	10,593	9,502	1,091	226,982	36,942	

**Special Needs Storm Shelters**

Name	Bldg #	Address	City	Zip			SpNS Capacity (spaces @ 60sf) (meets ARC 4496)	SpNs Capacity (sf) (meets ARC 4496)	SpNS Capacity (spaces @ 60sf) (does not meet ARC 4496)	Local Planned usage	Funding Source: Local (L), State (S), Federal (F), and Program Name	Comments
Hastings Community Center 2nd Tier	Aud	6195 S Main Street	Hastings	32145	R	P	266	16,000		200	S-1395B	
Pacetti Bay MS (Aug 2006)		245 Meadowlark Lane	St. Augustine	32092	N	P	500	60,000		300		

**2012 Statewide Emergency Shelter Plan**

**ST. LUCIE**

Name	Bldg. #	Address	City	Zip	Retrofitted (R) or New Construction (N)	General (G), PSN (P), Pet-Friendly (A)	Total Risk Capacity In People (Meets ARC 4496)	Total Risk Capacity (ft <sup>2</sup> ) (Meets ARC 4496)	Risk Capacity In People (Does not Meet ARC 4496 or Not Yet Surveyed)	Local Planned Usage (reported capacity)	Funding Source: Local (L), State (S), Federal (F), and Program Name	Comments
Bayshore ES	café	1661 SW Bayshore Blvd	Port St. Lucie	34984	R	G	499	12,481		220	S-1118A	plywood shutters per county
C.A. Moore Elementary School	9-Café	827 N 29th Street	Ft. Pierce	34947	R	G	677	16,917	0	412	S-1543	confirmed PBSJ report.
Copper Creek K-8		12051 Copper Creek Dr	Port St. Lucie	34987	N	G	500	10,000		500		
Dale Cassins School		1901 S 11th Street	Ft. Pierce	34947			0	0	0			
Fairlawn Elementary School		1900 S 33rd Street	Ft. Pierce	34947			0	0	100			no shutters- PB SJ report.
Floresta Elementary School	1	3201 S 25th Street	Ft. Pierce	34950	R	G	770	19,247		411	S-1118A	tilit up walls okay.
Forest Grove Middle School		1501 SE Floresta Drive	Port St. Lucie	34983			0	0	0			
Frances K. Sweet Elementary School		1400 Avenue Q	Ft. Pierce	34950			0	0	120			
Ft. Pierce Central High School		1101 Edwards Road	Ft. Pierce	34982			0	0	100			
Ft. Pierce Central High School		4101 S. 25th Street	Fort Pierce	34981	N	G	500	10,000		500		
Human Resources Dev Center	Gym				R	G	350	7,000			s-pa	
Lakewood Park Elementary School	1	7800 Indrio Road	Ft. Pierce	34951	R	G	605	15,118		215	S-1118A	
Lincoln Park Academy		1806 Avenue	Ft. Pierce	34950			0	0	100			
Manatee Elementary School	café	1450 SW Heatherwood	Port St. Lucie	34986	R	G	361	9,022		215	S	corridors and café only plywood shutters used locally.
Mariposa Elementary School	café	2620 SE Mariposa Avenue	Port St. Lucie	34952	R	G	361	9,022		225	S	corridors and café only plywood shutters used locally.
Morningside Elementary School	1	2300 SE Gowin Drive	Port St. Lucie	N/A	R	G	543	13,566		215	S-1118A	corridors and café only plywood shutters used locally.
Northport Middle School		250 NW Floresta	Port St. Lucie	34983			0	0	250			
Oak Hammock K-8 School	1	1251 SW California Blvd	Port St. Lucie	34953	N	G	1,521	30,425				PER PBSJ REPORT.
Oak Hammock K-8 School	2	1251 SW California Blvd	Port St. Lucie	34953	N	G	1,576	31,515				PER PBSJ REPORT.
Oak Hammock K-8 School	4	1251 SW California Blvd	Port St. Lucie	34953	N	G	513	12,826		500		PER PBSJ REPORT.
Oak Hammock K-8 School	5	1251 SW California Blvd	Port St. Lucie	34953	N	G	487	9,738				PER PBSJ REPORT.
Parkway ES	café	7000 NW Selvitz Road	Ft. Pierce	34981	R	G	417	10,418		220	S-1118A	Cafeteria only????
Dan Mc Carty MS	21	1201 Mississippi	Ft. Pierce	34950		G	220	4,400		220		
Port St. Lucie High School		1201 SE Lennard Road	Port St. Lucie	34952			0	0	150			
Samuel S Gaines K-8		2250 S Jenkins Road	Fort Pierce	34947	N	G	500	10,000		500		
Savanna Ridge ES	1-café	6801 Lennard Rd	Port St. Lucie	34982	R	G	677	16,917		516	S-1523-2002	
Southport Middle School		2420 SE Morningside	Port St. Lucie	34952			0	0	100			
St. Lucie SpNS/Auditorium		2000 Virginia Ave	Ft. Pierce	394945	N	P	0	0		500	CBIR S1508A	06CP-4Y-01-13-01-299.
St. Lucie West Middle School		1001 SW Juliet Avenue	Port St. Lucie	34986			0	0	450			
Treasure Coast HS		1000 SW Darwin BLVD	Port St. Lucie		N	G	1,875	46,874				
Village Green Elementary School	café	1700 Lennard Road	Port St. Lucie	34952	R	G	348	8,706		220	S-1118A	
Weatherbee ES	café	800 E. Weatherbee Rd	Port St. Lucie	34982	R	G	975	24,385		576	S-1523-2002	
West Gate K-8		1050 SW Cashmere Blvd	Port St. Lucie		N	G	500	10,000				
Westwood High School	1	1801 Panther Lane	Ft. Pierce	34947	R	G	1,733	43,326		632	S	verified by Irdm.
White City Elementary School		905 W 2nd Street	Ft. Pierce	34982			0	0	50			
Windmill Point Elementary School	café	700 Darwin Boulevard	Port St. Lucie	34983	R	G	377	9,435		220	S-1118a	
<b>TOTALS FOR ST. LUCIE COUNTY</b>							<b>16,885</b>	<b>391,338</b>	<b>1,420</b>	<b>7,017</b>		<b>0</b>
<b>Year 2012</b>	<b>Shelter Capacity In People</b>	<b>Shelter Demand In People</b>	<b>Surplus/ Deficit In People</b>	<b>Shelter Capacity (ft2)</b>			<b>Surplus/ Deficit (ft2)</b>		<b>Result</b>			
Storm Category 4/5	16,885	5,982	10,903	391,338			271,698					
<b>Special Needs Storm Shelters</b>												
<b>Name</b>	<b>Bldg #</b>	<b>Address</b>	<b>City</b>	<b>Zip</b>			<b>SpNS Capacity (spaces @ 60sf) (meets ARC 4496)</b>	<b>SpNs Capacity (sf) (meets ARC 4496)</b>	<b>SpNS Capacity (spaces @ 60sf) (does not meet ARC 4496)</b>	<b>local planned usage</b>	<b>Funding Source: Local (L), State (S), Federal (F), and Program Name</b>	<b>Comments</b>
Port St. Lucie Community Center	2	2195 SE Airoso Blvd	Port St. Lucie	34984			P	166	11,161	166		



**2012 Statewide Emergency Shelter Plan**

**ST. LUCIE**

H L Fenn Community Center		2000 Virginia Ave	Ft. Pierce	34945		<b>P</b>	334	20,040		<b>334</b>		06CP-4Y-01-13-01-299.
<b>Year 2012</b>	<b>SpNs Shelter Capacity In Spaces (meets ARC 4496)</b>	<b>SpNs Shelter Demand In Spaces</b>	<b>Surplus/ Deficit In Spaces</b>	<b>SpNs Shelter Capacity (ft2)</b>			<b>Surplus/ Deficit (ft2)</b>	<b>Result</b>				
	500	2,423	-1,923	30,000			-115,380					

**2012 Statewide Emergency Shelter Plan**

**SUMTER**

Name	Bldg. #	Address	City	Zip	Retrofitted (R) or New Construction (N)	General (G), PSN (P), Pet-Friendly (A)	Total Risk Capacity In People <small>(Meets ARC 4496)</small>	Total Risk Capacity (ft <sup>2</sup> ) <small>(Meets ARC 4496)</small>	Risk Capacity In People <small>(Does not Meet ARC 4496 or Not Yet Surveyed)</small>	Local Planned Usage (reported capacity)	Funding Source: Local (L), State (S), Federal (F), and Program Name	Comments
Bushnell Community Center		Highway 301& Belt Avenue	Bushnell	33513			0	0	100			
Bushnell Elementary School		218 W Flannery	Bushnell	33513			0	0	125			
Croom Road Baptist Church		12016 CR 681	Webster	33597			0	0	100			
DAV Building		CR 489	Lk Panasoffkee	33538			0	0	200			
First Baptist Church of Oxford		Creek Road & Highway 3	Oxford	34484			0	0	250			
Grant Lake Baptist Church		1444 CR 478 A	Webster	33597			0	0	140			
Lake Panasoffkee Elementary School		790 CR 482 North	Lk Panasoffkee	33538			0	0	100			
Lake Panasoffkee First Baptist Church		802 CR 470	Lk Panasoffkee	33538			0	0	100			
Lake Panasoffkee United Methodist Church		589 North CR 470	Lk Panasoffkee	33538			0	0	100			
North Sumter Intermediate School	18	300 East Huey Street	Wildwood	34785	R	G	178	3,059		178	HMGP	lrdm confirmed/per report 3565 sf
North Sumter Primary School	18	104 North Warfield Street	Wildwood	34785	R	G	0	0	178		HMGP	Questions on roof span - 68 ft.
South Sumter High School		7060 N Main St/SR 475	Bushnell	33513		G,A	0	0	450			
South Sumter Middle School		733 NW 10th Avenue	Webster	33597			0	0	250			
VFW		CR 476B	Nobleton	34661			0	0	100			
Villages Middle School		450 Village Campus/CR 4	Villages	32162	N	G	200	4,000	0	200	L	
Webster Elementary School	14	349 South Market Blvd	Webster	33597	R	G	0	0	138		HMGP	Questions on roof span - 68 ft.
Wildwood Community Center	1	700 Huey Street	Wildwood	34785	N	G	166	2,490		477	S-1395B	circa 2002
Wildwood High School		700 Huey Street	Wildwood	34785			0	0	450			
Wildwood Middle School		200 Cleveland Street	Wildwood	34785			0	0	200			
<b>TOTALS FOR SUMTER COUNTY</b>							<b>544</b>	<b>9,549</b>	<b>2,981</b>	<b>855</b>		
Year 2012	Shelter Capacity In People	Shelter Demand In People	Surplus/ Deficit In People	Shelter Capacity (ft2)			Surplus/ Deficit (ft2)	Result				
Storm Category 4/5	544	12,606	-12,062	9,549			-242,571					
<b>Special Needs Storm Shelters</b>												
Name	Bldg #	Address	City	Zip			SpNS Capacity (spaces @ 60sf) (meets ARC 4496)	SpNs Capacity (sf) (meets ARC 4496)	SpNS Capacity (spaces @ 60sf) (does not meet ARC 4496)	Local Planned Usage (reported capacity)	Funding Source: Local (L), State (S), Federal (F), and Program Name	Comments
TBD								0				
								0				
Year 2012	SpNs Shelter Capacity In Spaces (meets ARC 4496)	SpNs Shelter Demand In Spaces	Surplus/ Deficit In Spaces	SpNs Shelter Capacity (ft2)			Surplus/ Deficit (ft2)	Result				
Storm Category 4/5	0	42	-42	0			-2,520					

2012 Statewide Emergency Shelter Plan

SUWANNEE												
Name	Bldg. #	Address	City	Zip	Retrofitted (R) or New Construction (N)	General (G), PSN (P), Pet-Friendly (A)	Total Risk Capacity In People (Meets ARC 4496)	Total Risk Capacity (ft <sup>2</sup> ) (Meets ARC 4496)	Risk Capacity In People (Does not Meet ARC 4496 or Not Yet Surveyed)	Local Planned Usage (reported capacity)	Funding Source: Local (L), State (S), Federal (F), and Program Name	Comments
Assembly of God Church		26471 SR 247	Branford	32008			0	0				
Branford Community Center		Jenkins Ave (Hatch Park)	Branford	32008			0	0				
Branford Elementary School		26801 SR 247	Branford	32008	N	G	1,709	34,182		287		Whole school Ehpa per school-capacity per classrooms/dining/hallways
Branford High School		Governor's Street	Branford	32008			0	0		215		
Church of Jesus Christ of Latter Day Saints		1310 Irvin Avenue SW	Live Oak	32060		G	0	0				
First Advent Christian Church		699 Pinewood Way	Live Oak	32060			0	0				
First Baptist Church of Branford		503 Suwannee Avenue	Branford	32008			0	0				
First Baptist Church of Live Oak		401 Howard Street West	Live Oak	32060			0	0				
First Presbyterian Church		421 White Avenue	Live Oak	32060			0	0				
First United Methodist Church		311 Ohio Avenue South	Live Oak	32060			0	0				
Live Oak Church of God		9828 US 129	Live Oak	32060			0	0				
Mt. Olive Baptist Church		5314 98th Terrace	Wellborn	32094		G	0	0				
North Florida Christian Center		21670 West Shekinah Plac	OBrien	32071			0	0				
San Juan Mission Church		304 Plant Avenue SE	Branford	32008			0	0				
St. Francis Xavier Church		928 Howard Street East	Live Oak	32060		G	0	0				
St. Luke Episcopal Church		1391 Eleventh Street SW	Live Oak	32060			0	0				
Suwannee ES (new school) [0060]	1	1748 South Ohio Ave	Live Oak	32060	N	G	1,775	35,509		400		Whole school Ehpa per school-capacity per classrooms/dining/hallways
Suwannee High School (Suwannee Snr High) [0043]		1314 Pine Ave SW	Live Oak	32064		G	0	0		75		
Suwannee Middle School [0051]		1730 Walker Street SW	Live Oak	32064		G	0	0		130		
Suwannee Primary School (Suv Elem East) [0011]	361/001	1625 Walker Ave SW	Live Oak	32064	R	G/P	0	0		180	L, S, F	0
Suwannee-Hamilton Technical Center [0012]		415 Pinewood Dr SW	Live Oak	32064		G	0	0		60		
<b>TOTALS FOR SUWANNEE COUNTY</b>							<b>3,484</b>	<b>69,691</b>	<b>0</b>	<b>1,347</b>		<b>0</b>
<b>Year 2012</b>	<b>Shelter Capacity In People</b>	<b>Shelter Demand In People</b>	<b>Surplus/ Deficit In People</b>	<b>Shelter Capacity (ft2)</b>			<b>Surplus/ Deficit (ft2)</b>	<b>Result</b>				
Storm Category 4/5	3,484	2,852	632	69,691			12,651					
<b>Special Needs Storm Shelters</b>												
<b>Name</b>	<b>Bldg #</b>	<b>Address</b>	<b>City</b>	<b>Zip</b>			<b>SpNS Capacity (spaces @ 60sf) (meets ARC 4496)</b>	<b>SpNs Capacity (sf) (meets ARC 4496)</b>	<b>SpNS Capacity (spaces @ 60sf) (does not meet ARC 4496)</b>	<b>Local Planned Usage (reported capacity)</b>	<b>Funding Source: Local (L), State (S), Federal (F), and Program Name</b>	<b>Comments</b>
Suwannee Intermediate School (Suv.ESWest) [0042]	Caf & Multi-Purp	1419 Walker Ave. SW	Live Oak	32,064	R	P	50	3,000		50		
<b>Year 2012</b>	<b>SpNs Shelter Capacity In Spaces (meets ARC 4496)</b>	<b>SpNs Shelter Demand In Spaces</b>	<b>Surplus/ Deficit In Spaces</b>	<b>SpNs Shelter Capacity (ft2)</b>			<b>Surplus/ Deficit (ft2)</b>	<b>Result</b>				
Storm Category 4/5	50	78	-28	3,000			-1,680					

**2012 Statewide Emergency Shelter Plan**

**TAYLOR**

Name	Bldg. #	Address	City	Zip	Retrofitted (R) or New Construction (N)	General (G), PSN (P), Pet-Friendly (A)	Total Risk Capacity In People (Meets ARC 4496)	Total Risk Capacity (ft <sup>2</sup> ) (Meets ARC 4496)	Risk Capacity In People (Does not Meet ARC 4496 or Not Yet Surveyed)	Local Planned Usage (reported capacity)	Funding Source: Local (L), State (S), Federal (F), and Program Name	Comments
Elks Lodge		305 Puckett Road	Perry	32348			0	0	100			
Fellowship Baptist Church		1st Avenue	Steinhatchee	32359			0	0	70			in cat 3 surge zone
Forest Capital Hall		203 Forest Park Dr	Perry	32349			0	0				
Mormon Church		Woods Creek Road	Perry	32347			0	0	40			
Perry Primary School		400 North Clark Street	Perry	32347			0	0	275			
Steinhatchee School		1209 1st Avenue SE	Steinhatchee	32359			0	0	70			in cat 2 surge zone
Taylor County High School	Bldg C	900 Johnson-Stripping Rd	Perry	32347	R	G	209	4,180			S-1496-2009	
Taylor County Middle School		601 E. Lafayette Street	Perry	32347			0	0	265			
Taylor County ES (NEW)	3	1600 East Green St	Perry	32347	N	G	796	13,310		796	L	
Taylor County ES (NEW)	7 - café	1600 East Green St	Perry	32347	R	G	467	9,340			S-1496-2009	
Taylor County ES (NEW)	1 - admin	1600 East Green St	Perry	32347	R	G	250	5,000			S-1496-2010	
Taylor County ES (NEW)	2 - Media	1600 East Green St	Perry	32347	R	G	276	5,520			S-1496-2011	
Taylor County ES (NEW)	4	1600 East Green St	Perry	32347	N	G	380	5,701		401	L	
Taylor County ES (NEW)	5	1600 East Green St	Perry	32347	N	G	438	6,840		438	L	
Taylor County ES (NEW)	6	1600 East Green St	Perry	32347	N	G	810	12,143		875	L	
Taylor Technical Institute		3233 S US Highway 19	Perry	32348			0	0	265			
Covenant Christian Fellowship Church		6050 Pucket Rd	Perry	32348		G	0	0	265			in cat 5 surge zone
<b>TOTALS FOR TAYLOR COUNTY</b>							<b>3,626</b>	<b>62,034</b>	<b>1,350</b>	<b>2,511</b>		<b>0</b>

Year 2012	Shelter Capacity In People	Shelter Demand In People	Surplus/ Deficit In People	Shelter Capacity (ft <sup>2</sup> )	Surplus/ Deficit (ft <sup>2</sup> )	Result
Storm Category 4/5	3,626	1,523	2,103	62,034	31,574	

**Special Needs Storm Shelters**

Name	Bldg #	Address	City	Zip	SpNS Capacity (spaces @ 60sf) (meets ARC 4496)	SpNs Capacity (sf) (meets ARC 4496)	SpNS Capacity (spaces @ 60sf) (does not meet ARC 4496)	Local Planned Usage (reported capacity)	Funding Source: Local (L), State (S), Federal (F), and Program Name
Uses Regional Shelter						0			
						0			

Year 2012	SpNs Shelter Capacity In Spaces (meets ARC 4496)	SpNs Shelter Demand In Spaces	Surplus/ Deficit In Spaces	SpNs Shelter Capacity (ft <sup>2</sup> )	Surplus/ Deficit (ft <sup>2</sup> )	Result
Storm Category 4/5	0	72	-72	0	-4,320	

updated 11/01/11

**2012 Statewide Emergency Shelter Plan**

**UNION**

Name	Bldg. #	Address	City	Zip	Retrofitted (R) or New Construction (N)	General (G), PSN (P), Pet-Friendly (A)	Total Risk Capacity In People (Meets ARC 4496)	Total Risk Capacity (ft <sup>2</sup> ) (Meets ARC 4496)	Risk Capacity In People (Does not Meet ARC 4496 or Not Yet Surveyed)	Local Planned Usage (reported capacity)	Funding Source: Local (L), State (S), Federal (F), and Program Name	Comments
Lake ButlerES	21	800 SW 6th Street	Lake Butler	32054	R	G	0	0	0			host shelter
Lake Butler Agricultural Center Building		Hwy 231 South	Lake Butler	32054			0	0	0			
Lake Butler Middle School	3,5,6	120 SW 6th Street	Lake Butler	32054	R	G	939	23,465	150	424	HMGP	funded 424
Lake Butler Middle School Gyrr		801 S Lake Avenue	Lake Butler	32054			0	0	50			
NFRC-DOC Training Building		Hwy 238 West	Providence	32083			0	0	30			
Providence Community Center		Hwy 121 North	Raiford	32054			0	0	75			
Raiford Community Center		Hwy 121/16	Raiford	32054			0	0	0			
RMC-DOC Training Bldg		15540 SW 158th LN	Lake Butler	32054		G	0	0	75		S	DOC Families only
UCI-DOC Training Building		Hwy 121 South	Worthington	32697			0	0	75		S	DOC Families only
Union County High School	21	1000 S Lake Avenue	Lake Butler	32054	N	G	169	3,386	0	1,000	L, S	
Union County High School	23	850 S Lake Avenue	Lake Butler	32054	N	G	143	2,854	0	200		
Union County High School Physical Ed Bld	24	150 SW 6th Street	Lake Butler	32054	N	P	0	0	0		L, S	Special needs only
<b>TOTALS FOR UNION COUNTY</b>							<b>1,251</b>	<b>29,705</b>	<b>455</b>	<b>1,624</b>		<b>0</b>

Year 2012	Shelter Capacity In People	Shelter Demand In People	Surplus/ Deficit In People	Shelter Capacity (ft2)		Surplus/ Deficit (ft2)	Result
Storm Category 4/5	1,251	951	300	29,705		10,685	

**Special Needs Storm Shelters**

Name	Bldg #	Address	City	Zip			SpNS Capacity (spaces @ 60sf) (meets ARC 4496)	SpNs Capacity (sf) (meets ARC 4496)	SpNS Capacity (spaces @ 60sf) (does not meet ARC 4496)	Local Planned Usage (reported capacity)	Funding Source: Local (L), State (S), Federal (F), and Program Name	Comments
Union County High School Physical Ed Bld	24	150 SW 6th Street	Lake Butler	32054	N	P	33	2,010		45		
								0				
								0				
								0				
								0				
								0				

Year 2012	SpNs Shelter Capacity In Spaces (meets ARC 4496)	SpNs Shelter Demand In Spaces	Surplus/ Deficit In Spaces	SpNs Shelter Capacity (ft2)		Surplus/ Deficit (ft2)	Result
Storm Category 4/5	33	61	-28	1,980		-1,680	

2012 Statewide Emergency Shelter Plan

VOLUSIA

Name	Bldg. #	Address	City	Zip	Retrofitted (R) or New Construction (N)	General (G), PSN (P), Pet-Friendly (A)	Host Capacity In People	Total Risk Capacity In People (Meets ARC 4496)	Total Risk Capacity (ft <sup>2</sup> ) (Meets ARC 4496)	Risk Capacity In People (Does not Meet ARC 4496 or Not Yet Surveyed)	Local Planned Usage (reported capacity)	Funding Source: Local (L), State (S), Federal (F), and Program Name	Comments
Allen Green Civic Center							N/A	600	12,000		600	EMPA	funded 600
Atlantic High School	1-Café	1250 Reed Canal	Port Orange	32171			N/A	0	0	0		L	unshuttered windows.
Atlantic High School	3-ESE CR	1250 Reed Canal	Port Orange	32171	R	P	N/A	0	0	0	0		Spns See below,
Atlantic High School	8-Gym	1250 Reed Canal	Port Orange	32171			N/A	0	0			L	unshuttered windows.
Blue Lake Elementary School		282 North Blue Lake Ave	DeLand	32724			N/A	0	0	249			
Campbell Middle School	2-Café	625 S. Keech St.	Daytona Beach	32124	N	G	N/A	0	0	0	250	L	342 persons, exiting storm only
Campbell Middle School	3-Classroom	625 S. Keech St.	Daytona Beach	32124	R	G	N/A	0	0			L	544 persons, exiting storm only
Campbell Middle School	4-Classroom	625 S. Keech St.	Daytona Beach	32124	R	G	N/A	0	0			L	573 persons, exiting storm only
Campbell Middle School	5-ESE CR	625 S. Keech St.	Daytona Beach	32124	R	G	N/A	0	0			L	144 persons, exiting storm only
Campbell Middle School	6-Classroom	625 S. Keech St.	Daytona Beach	32124	R	G	N/A	0	0			L	544 persons, exiting storm only
Campbell Middle School	9-Gym	625 S. Keech St.	Daytona Beach	32124	R	G	N/A	0	0			L	433 persons, exiting storm only
Champion Elementary School (K-5)	5-café	921 Tournament Drive,	Daytona Beach	32124	N	G	N/A	163	4,083		150	L	ehpa per county, FISH Data
Citrus Grove Elementary (K-5)	3-café	729 Hazen Road,	DeLand	32720	N	G	N/A	161	4,032		150	L	ehpa per county, FISH Data
Creekside Middle School	3	6801 Airport Road	Port Orange	32171		G	N/A	396	7,911				Updated FISH Data
Creekside Middle School	4	6801 Airport Road	Port Orange	32171		G	N/A	408	8,151				Updated FISH Data
Creekside Middle School	6	6801 Airport Road	Port Orange	32171		G	N/A	408	8,161				Updated FISH Data
Creekside Middle School	2-Café	6801 Airport Road	Port Orange	32171	N	P	N/A	0	0		125	L, S	See SpNS
Creekside Middle School	9-Gym	6801 Airport Road	Port Orange	32171		G,A	N/A	449	8,985				Updated FISH Data
Cypress Creek Elementary School	5-café	6100 S. Williamson Blvd	Port Orange	32127	N	G	N/A	0	0		150	L	300 persons, exiting storm only
Daytona Beach Community College East	16	1200 West Intl Speedway	Daytona Beach	32114	R	G	N/A	322	6,440	0	322	HMGP	
Daytona Beach Community College West	5	1155 County Road 4139	DeLand	32724	R	G	N/A	145	2,900	0	145	HMGP	
DeBary Elementary School	1	88 W Highbanks Road	DeBary	32713	R	G	N/A	590	8,850	0	722	L	Updated FISH Data
DeBary Elementary School	2	88 W Highbanks Road	DeBary	32713			N/A	0	0				
DeBary Elementary School	4	88 W Highbanks Road	DeBary	32713	N	G	N/A	165	4,126		150		ehpa:updated FISH
DeLand High School	1	800 N. Hill Ave DeLand	DeLand	32724	R	G	N/A	0	0				
DeLand High School	2	800 N. Hill Ave DeLand	DeLand	32724			N/A	0	0			L	
DeLand High School	5	800 N. Hill Ave DeLand	DeLand	32724	R	G	N/A	400	7,455		400	L	shuttered per county, updated FISH
DeLand High School	7	800 N. Hill Ave DeLand	DeLand	32724			N/A	0	0			L	
DeLand High School	14	800 N. Hill Ave DeLand	DeLand	32724	R	G	N/A	574	11,482			L	shuttered per county, updated FISH
DeLand High School	15	800 N. Hill Ave DeLand	DeLand	32724	R	G	N/A	581	11,627			L	shuttered per county, updated FISH
DeLand High School	17	800 N. Hill Ave DeLand	DeLand	32724			N/A	0	0			L	
DeLand High School	1a	800 N. Hill Ave DeLand	DeLand	32724	N	G	N/A	800	12,895			L	
DeLand High School (2005)	39	800 N. Hill Ave DeLand	DeLand	32724	N	G	N/A	228	4,555				ehpa-2005
DeLand Middle School	4	1400 S Aquarius Avenue	DeLand	32724			N/A	635	9,523	0	250	L	
DeLand Middle School	13	1400 S Aquarius Avenue	DeLand	32724			N/A	0	0				
DeLand Middle School	15	1400 S Aquarius Avenue	DeLand	32724			N/A	0	0				
DeLand Middle School	16	1400 S Aquarius Avenue	DeLand	32724			N/A	0	0				
Deltona High School	15-Classrooms portion	100 Wolf Pack Run	Deltona	32725	R	G	N/A	127	2,530				
Deltona High School	27	101 Wolf Pack Run	Deltona	32725	R	G	N/A	191	3,824				
Deltona High School	14-café	102 Wolf Pack Run	Deltona	32725	R	G	N/A	222	4,449		400	L	shuttered per county
Deltona High School	15-gym	100 Wolf Pack Run	Deltona	32725	R	G	N/A	0	0		0	L	unprotected windows?
Deltona High School	16-ese	100 Wolf Pack Run	Deltona	32725	R	G	N/A	0	0		0		
Deltona Lakes Elementary School	8	2022 Adelia Boulevard	Deltona	32728			N/A	131	1,968	274	150	L	
Deltona Lakes Elementary School	9	2022 Adelia Boulevard	Deltona	32728			N/A	0	0				
Discovery Elementary School	1	975 Abigail Drive	Deltona	32725			N/A	207	5,470	252	150	L	
Discovery Elementary School	2	975 Abigail Drive	Deltona	32725			N/A	0	0				
Discovery Elementary School	4	975 Abigail Drive	Deltona	32725			N/A	0	0				
Discovery Elementary School	5	975 Abigail Drive	Deltona	32725			N/A	0	0				
Discovery Elementary School	3-Café-Band	975 Abigail Drive	Deltona	32725	R	G	N/A	220	4,408			L	
Forest Lake Elementary School	2	1600 Doyle Road	Deltona	32725	R	G	N/A	250	5,097	0	0	F	
Forest Lake Elementary School	3	1600 Doyle Road	Deltona	32725			N/A	0	0				
Forest Lake Elementary School	4	1600 Doyle Road	Deltona	32725			N/A	0	0				
Forest Lake Elementary School	5-café	1600 Doyle Road	Deltona	32725	R	G	N/A	238	4,755		150	L	
Freedom Elementray School	3	1395 South Blue Lake	DeLand	32724	N	P	N/A	0	0		150		Spns See below,
Freedom Elementray School	4	1395 South Blue Lake	DeLand	32724	N	P	N/A	0	0				Spns See below,
Freedom Elementray School	2-café	1395 South Blue Lake	DeLand	32724	N	P	N/A	0	0			L	Spns See below,
Friendship Elementary School	2	2746 Fulford Street	Deltona	32725			N/A	409	6,871	255		L	
Friendship Elementary School	3	2746 Fulford Street	Deltona	32725			N/A	0	0				
Friendship Elementary School	4-Dining	2746 Fulford Street	Deltona	32725	R	G	N/A	245	4,893		150	L	ehpa
Galaxy Middle School	2-Café	2400 Eustace Avenue	Deltona	32725	R	P	N/A	0	0		250	S-1118a	Spns See below,
Galaxy Middle School	9-gym	2400 Eustace Avenue	Deltona	32725			N/A	0	0				
Heritage Middle School	2-café	1001 Parnell Court	Deltona	32725	R	G	N/A	0	0		125	F	
Heritage Middle School	3-cr	1001 Parnell Court	Deltona	32725	R	G	N/A	469	9,385			I	ehpa

2012 Statewide Emergency Shelter Plan

VOLUSIA

Heritage Middle School	4-cr	1001 Parnell Court	Deltona	32725	R	G	N/A	437	8,740								ehpa
Heritage Middle School	6-cr	1001 Parnell Court	Deltona	32725	R	G	N/A	470	9,402								ehpa
Heritage Middle School	9-gym	1001 Parnell Court	Deltona	32725		G,A	N/A	0	0								
University High School	Cafeteria-bldg 11	1000 W Rhode Island Ave	Orange City	32763	N	(G)	400	400	8,000		400	L					EHPA yes-2011
Horizon Elementary School	7-café	4751 Hidden Lake Drive	Port Orange	32127	R	G	N/A	0	0	0	150	F					as-is
James Park Youth Action Center	main	1700 James Street	South Daytona	32111	R	G	N/A	0	0	0	0	S-1395B					80 persons, exiting storm only
Mainland HS	2A-Café	Clyde Morris Blvd	Daytona Beach	32124	R	G	N/A	208	4,156		400						
Mainland HS	3-Gym	Clyde Morris Blvd	Daytona Beach	32124	N	G	N/A	1,750	35,000								
Manatee Cove Elementary (old X elementary)	1	734 W. Ohio Avenue	Orange City	32763	R	G	N/A	0	0		0	L					
Manatee Cove Elementary	2	734 W. Ohio Avenue	Orange City	32763	R	G	N/A	254	5,073								shuttered per county (surveyed as X elementary)
Manatee Cove Elementary	3	734 W. Ohio Avenue	Orange City	32763	R	G	N/A	481	9,610								shuttered per county
Manatee Cove Elementary	4	734 W. Ohio Avenue	Orange City	32763	R	G	N/A	417	8,344		150						shuttered per county
New Smyrna Beach HS	3-Gym	10th St	New Smyrna	32169	N	G	N/A	0	0		500	L					847 persons, exiting storm only
New Smyrna Beach HS	8-Café	10th St	New Smyrna	32169	N	G	N/A	0	0			L					316 persons, exiting storm only
Osteen Elementary School	2-Cafeteria	500 Doyle Road	Osteen	32764	N	G	N/A	125	2,500			L					ehpa per county,
Palm Terrace Elementary School	1-entire	1825 Dunn Avenue	Daytona Beach	32124	R	P,A	N/A	0	0		0	F					Spns See below,
Pathways Elementary School	2-cr	2100 Airport Road	Ormond Beach	32714	R	G	N/A	250	5,253	0	0	F					
Pathways Elementary School	3-cr	2100 Airport Road	Ormond Beach	32714			N/A	0	0								
Pathways Elementary School	4-cr	2100 Airport Road	Ormond Beach	32714			N/A	0	0								
Pathways Elementary School	5-café	2100 Airport Road	Ormond Beach	32714	R	G	N/A	238	4,755		150						
Piggotte Center		504 Big Tree Road	South Daytona	32111	R	G	N/A	0	0	0		S-1395B					100 persons, exiting storm only
Pine Ridge High School	3	925 Howland Boulevard	Deltona	32725			N/A	0	0								
Pine Ridge High School	5	925 Howland Boulevard	Deltona	32725			N/A	0	0								
Pine Ridge High School	10-auditorium	925 Howland Boulevard	Deltona	32725			N/A	0	0								
Pine Ridge High School	1-café	925 Howland Boulevard	Deltona	32725	R	G	N/A	327	5,308		400	L					
Pine Ridge High School	7-cr	925 Howland Boulevard	Deltona	32725			N/A	0	0								
Pine Ridge High School	8-gym	925 Howland Boulevard	Deltona	32725			N/A	0	0								
Pine Ridge High School	9-music	925 Howland Boulevard	Deltona	32725			N/A	0	0								
Pine Trail Elementray School	6-café	300 Airport Road	Ormond Beach	32714			N/A	254	4,090		150						
Port Orange ES	5	402 Dunlawton Ave	Port Orange	32127	R	G	N/A	0	0								no longer used as shelter
Port Orange YMCA	4701-Day	4701 City Center Pkwy	Port Orange	32127	N	G	N/A	125	2,500	0	125	S-1395B					
Port Orange YMCA	4701-PE	4701 City Center Pkwy	Port Orange	32127	N	G	N/A	200	4,000	0	200	L & S					
Pride Elementary School	cafeteria-3	1100 Learning Lane	Deltona	32738	N	G	150	170	4,245		150	L					
River Springs Middle School	cafeteria-2	900 West Ohio Ave	Orange City	32763	N	G	250	386	9,646		250	L					
Sea breeze HS	1	2700 N. Oleander ave	Daytona Beach	32118			N/A	0	0								exiting storm only, 11.19' SLOSH
Sea breeze HS	13	2700 N. Oleander ave	Daytona Beach	32118			N/A	0	0								exiting storm only, 11.19' SLOSH
Sea breeze HS	14	2700 N. Oleander ave	Daytona Beach	32118			N/A	0	0								exiting storm only, 11.19' SLOSH
Sea breeze HS	15	2700 N. Oleander ave	Daytona Beach	32118			N/A	0	0								exiting storm only, 11.19' SLOSH
Southwestern MS	5	605 W New Hampshire Ave	Deland	32720			N/A	461	6,916								ehpa-2005,
Spirit Elementary	1	1500 Meadowlark Dr	Deltona	32728			N/A	276	5,521								shuttered per county
Spirit Elementary	2	1500 Meadowlark Dr	Deltona	32728	N	G	N/A	191	3,820		150	L					ehpa
Spirit Elementary	3	1500 Meadowlark Dr	Deltona	32728			N/A	425	8,501								ehpa
Spirit Elementary	4	1500 Meadowlark Dr	Deltona	32728			N/A	353	7,059								ehpa
Sunrise Elementary School	2-cr	3155 Phonetia Drive	Deltona	32725	R	G	N/A	300	7,283	255		L					
Sunrise Elementary School	3-cr	3155 Phonetia Drive	Deltona	32725	R	G	N/A	0	0								
Sunrise Elementary School	4-café	3155 Phonetia Drive	Deltona	32725	R	G	N/A	245	4,893		150						
Sweetwater Elementary School	2-cr	5800 Victoria Gardens	Port Orange	32127	R	G	N/A	262	5,115	0	0	F					
Sweetwater Elementary School	3-cr	5800 Victoria Gardens	Port Orange	32127			N/A	0	0								
Sweetwater Elementary School	4-cr	5800 Victoria Gardens	Port Orange	32127			N/A	0	0								
Sweetwater Elementary School	5-café	5800 Victoria Gardens	Port Orange	32127			N/A	0	0		150						
Sweetwater Elementary School	6-library	5800 Victoria Gardens	Port Orange	32127			N/A	0	0								
T.D. Taylor MS	2-classroom	100 East Washington Ave	Pierson	32080	N	G	N/A	171	3,411								ehpa-2005
T.D. Taylor MS	7-Gym	101 East Washington Ave	Pierson	32080	N	G	N/A	544	10,872		400						ehpa-2005
Timbercrest Elementary School	1-library	2401 Eustace Avenue	Deltona	32725	R	G	N/A	223	3,344	0		F					
Timbercrest Elementary School	2-cr	2401 Eustace Avenue	Deltona	32725			N/A	0	0								
Timbercrest Elementary School	3-cr	2401 Eustace Avenue	Deltona	32725			N/A	0	0								
Timbercrest Elementary School	4-café	2401 Eustace Avenue	Deltona	32725	R	G	N/A	245	4,893		150						
Volusia county Fairground	Tommy Lawr	3150 E. NY Ave	Deland	32724	R	G, A	N/A	500	10,000	250		L					
Volusia Pines Elementray School	2-cr	500 Kicklighter Road	Lake Helen	32744	R	G	N/A	250	5,097	0		F					
Volusia Pines Elementray School	3-cr	500 Kicklighter Road	Lake Helen	32744			N/A	0	0								
Volusia Pines Elementray School	4-cr	500 Kicklighter Road	Lake Helen	32744	R	G	N/A	264	5,278								
Volusia Pines Elementray School	5-café	500 Kicklighter Road	Lake Helen	32744			N/A	0	0		150						
Volusia Pines Elementray School	6-library	500 Kicklighter Road	Lake Helen	32744			N/A	0	0								
<b>TOTALS FOR VOLUSIA COUNTY</b>								<b>800</b>	<b>20,936.00</b>	<b>409,451.00</b>	<b>1,535.00</b>	<b>9,614.00</b>					<b>0</b>

Year 2012	Shelter Capacity In People	Shelter Demand In People	Surplus/ Deficit In People	Shelter Capacity (ft2)			Shelter Demand (ft2)	Surplus/ Deficit (ft2)	Result
Storm Category 4/5	20,936	38,008	-17,072	409,451			760,160	-350,709	
<b>Special Needs Storm Shelters</b>									

2012 Statewide Emergency Shelter Plan

VOLUSIA

Name	Bldg. #	Address	City	Zip			Emergency Powered HVAC?	SpNS Capacity (spaces @ 60sf) (meets ARC 4496)	SpNs Capacity (sf) (meets ARC 4496)	SpNS Capacity (spaces @ 60sf) (does not meet ARC 4496)	Local Planned Usage (reported capacity)	Funding Source: Local (L), State (S), Federal (F), and Program Name	Comments
Atlantic HS	3-ESE CR	1250 Reed Canal	Port Orange	32171	R	P	Yes	107	4,818	0	282		EHPA; 45sqft/person used for Cap
Creekside MS	2-Café	6801 Airport Road	Port Orange	32171	N	P	Yes	104	6,220		336		Updated FISH Data,
Freedom ES	2-café	1395 South Blue Lake	DeLand	32724	N	P	Yes	63	3,820		84		Updated FISH Data,
Freedom ES	3-classroom	1395 South Blue Lake	DeLand	32724	N	P	Yes	158	9,494				Updated FISH Data,
Freedom ES	4-classroom	1395 South Blue Lake	DeLand	32724	N	P,A	Yes	126	7,570				Updated FISH Data,
Galaxy MS	2-Café	2400 Eustace Avenue	Deltona	32725	N	P	Yes	110	6,608		429		Updated FISH Data,
Heritage MS	2-café	1001 Parnell Court	Deltona	32725	R	P	No	107	6,449		264		Updated FISH Data,
Hinson Middle School	3	1860 N. Clyde Morris Blvd	Ormond Beach	32174	R	P		162	9,729				shuttered per county
Hinson Middle School	4	1860 N. Clyde Morris Blvd	Ormond Beach	32174	R	P		162	9,705				shuttered per county
Hinson Middle School	5	1860 N. Clyde Morris Blvd	Ormond Beach	32174	R	P		58	3,462				shuttered per county
Hinson Middle School	6	1860 N. Clyde Morris Blvd	Ormond Beach	32174	R	P		108	6,509				shuttered per county
Hinson Middle School	9	1860 N. Clyde Morris Blvd	Port Orange	32174	N	P,A		138	8,301				ehpa,
Hinson Middle School	2-café	1860 N. Clyde Morris Blvd	Ormond Beach	32174	N	P	300	120	7,184	0	250	L	ehpa
Palm Terrace ES	1-entire	1825 Dunn Avenue	Daytona Beach	32124	R	P,A	No	715	42,915		715		
<b>Year 2012</b>	<b>SpNs Shelter Capacity In Spaces (meets ARC 4496)</b>	<b>SpNs Shelter Demand In Spaces</b>	<b>Surplus/ Deficit In Spaces</b>	<b>SpNs Shelter Capacity (ft2)</b>			<b>Shelter Demand (ft2)</b>	<b>Surplus/ Deficit (ft2)</b>	<b>Result</b>				
Storm Category 4/5	2,238.00	241	1,997	134,280			14,460	119,820					



**2012 Statewide Emergency Shelter Plan  
WAKULLA**

Name	Bldg. #	Address	City	Zip	Retrofitte d (R) or New Construc tion (N)	General (G), PSN (P), Pet - Friendly (A)	Total Risk Capacity In People <i>(Meets ARC 4496)</i>	Total Risk Capacity <i>(ft<sup>2</sup>)</i> <i>(Meets ARC 4496)</i>	Risk Capacity In People <i>(Does not Meet ARC 4496 or Not Yet Surveyed)</i>	Local Planned Usage (reported capacity)	Funding Source: Local (L), State (S), Federal (F), and Program Name	Comments
Crawfordville ES	200	379 Arron Road	Crawfordville	32327	N	G	400	6,711		400	L	
Medart Elementary School		2558 Coastal Highway	Crawfordville	32327			0	0	300			
Mormon Church		US Highway 319 South	Crawfordville	32327			0	0	100			
River of Life		10 Faith Ave	Sopchoppy	32358		G	0	0	0			
Ochlockonee Bay United Methodist Church		45 Warrior Way	Crawfordville	32327			0	0	125			
Shadeville Elementary School		3237 Coastal Highway	Crawfordville	32327			0	0	0			
Sopchoppy School		Surf Road	Panacea	32346			0	0	200			
Wakulla County High School		164 Yellow Jacket Avenue	Sopchoppy	32358			0	0	290			
Riversink Elementary School		530 Lonnie Raker Lane	Crawfordville	32327	N	G	400	6,711		400	L	New School 2008
<b>TOTALS FOR WAKULLA COUNTY</b>							<b>800</b>	<b>13,422</b>	<b>1,015</b>	<b>800</b>		<b>0</b>

Year 2012	Shelter Capacity In People	Shelter Demand In People	Surplus/ Deficit In People	Shelter Capacity (ft2)	Surplus/ Deficit (ft2)	Result
Storm Category 4/5	800	943	-210	13,422	-6,778	

**Special Needs Storm Shelters**

Name	Bldg. #	Address	City	Zip	SpNS Capacity (spaces @ 60sf) (meets ARC 4496)	SpNs Capacity (sf) (meets ARC 4496)	SpNS Capacity (spaces @ 60sf) (does not meet ARC 4496)	Local Planned Usage (reported capacity)	Funding Source: Local (L), State (S), Federal (F), and Program Name	Comments
Uses Regional Shelter						0				
						0				

Year 2012	SpNs Shelter Capacity In Spaces (meets ARC 4496)	SpNs Shelter Demand In Spaces	Surplus/ Deficit In Spaces	SpNs Shelter Capacity (ft2)	Surplus/ Deficit (ft2)	Result

**2012 Statewide Emergency Shelter Plan**

**WALTON**

Name	Bldg. #	Address	City	Zip	Retro fitted (R) or New Const	Gener al (G), PSN (P), Pet - Friend	Total Risk Capacity In People (Meets ARC 4496)	Total Risk Capacity (ft <sup>2</sup> ) (Meets ARC 4496)	Risk Capacity In People (Does not Meet ARC 4496 or Not Yet Surveyed)	Local Planned Usage (reported capacity)	Funding Source: Local (L), State (S), Federal (F), and Program Name	Comments
Freeport HS	1-partial	12615 Hwy 331 South	Freeport	32439	N	G	1,310	28,819	0	2,630	L	per State Study
Freeport HS	1-partial	12615 Hwy 331 South	Freeport	32439	R	G	1,320	30,264			S-1588-2006	portion of bldg updated FISH
OWCC/Chautauqua Neighborhood Center	2	908 US HWY 90 West	DeFuniak Springs	32433	R	G	401	8,020		401	S-1588-2005	
Mossy Head Elementary School	Wing 100-Admin	13270 Hwy 90 West	DeFuniak Springs	32433	N	G	52	1,041		52		Arc 4496 per state study
Mossy Head Elementary School	Wing 200-300	13271 Hwy 90 West	DeFuniak Springs	32434	N	G	708	15,966		708		Ehpa per study
Mossy Head Elementary School	Wing 400	13272 Hwy 90 West	DeFuniak Springs	32435	N	G	296	5,911		296		Arc 4496 per state study
Mossy Head Elementary School	Wing 500	13273 Hwy 90 West	DeFuniak Springs	32436	N	G	337	6,733		337		Arc 4496 per state study
Mossy Head Elementary School	Wing 600	13274 Hwy 90 West	DeFuniak Springs	32437	N	G	91	1,829		91		Arc 4496 per state study
Paxton High School (new)	100-admin	Hwy 331	Paxton	32538	N	G	287	5,743		287		Arc 4496 per state study
Paxton High School (new1)	100-Aud	Hwy 331	Paxton	32538	N	G	199	3,972		199		Arc 4496 per state study
South Walton HS	all	645 Greenway Trail	Santa Rosa Bch	32459	R	G	0	0				
South Walton HS		645 Greenway Trail	Santa Rosa Bch	32459	R	G	953	19,052		1,751	S-1508-2005	per State Study
South Walton HS		645 Greenway Trail	Santa Rosa Bch	32459	N	G	1,507	30,126				per State Study
Walton High School	Auditorium	449 Walton Rd	DeFuniak Springs	32433	N	G	285	5,704		285		per reports
Walton High School	Gym	449 Walton Rd	DeFuniak Springs	32433	N	G	677	13,530		677		per reports
Walton High School	SW-SE Wing	449 Walton Rd	DeFuniak Springs	32433	N	G	626	12,513		626		per reports
Walton High School	Café-South Wing	449 Walton Rd	DeFuniak Springs	32433	N	G	156	3,120				per reports
Walton MS	900	625 Park Avenue	DeFuniak Springs	32435	R	P	0	0		92	S-1508-2005	
West DeFuniak Elementary School			DeFuniak Springs	32435			0	0	0			
<b>TOTALS FOR WALTON COUNTY</b>							<b>9,205</b>	<b>192,343</b>	<b>0</b>	<b>8,432</b>		<b>0</b>

Year 2012	Shelter Capacity In People	Shelter Demand In People	Surplus/ Deficit In People	Shelter Capacity (ft <sup>2</sup> )	Surplus/ Deficit (ft <sup>2</sup> )	Result
Storm Category 4/5	9,205	2,035	7,170	#####	151,643	

**Special Needs Storm Shelters**

Name	Bldg. #	Address	City	Zip	SpNS Capacity (spaces @ 60sf) (meets ARC 4496)	SpNs Capacity (sf) (meets ARC 4496)	SpNS Capacity (spaces @ 60sf) (does not meet ARC 4496)	Local Planned Usage (reported capacity)	Funding Source: Local (L), State (S), Federal (F), and Program Name	Comments
Walton MS (Already Funded)	900	625 Park Avenue	DeFuniak Springs	32435		92	5,502	92		per State Study

Year 2012	SpNs Shelter Capacity In Spaces (meets ARC 4496)	SpNs Shelter Demand In Spaces	Surplus/ Deficit In Spaces	SpNs Shelter Capacity (ft <sup>2</sup> )	Surplus/ Deficit (ft <sup>2</sup> )	Result
Storm Category 4/5	92	56	36	5,520	2,160	

**2012 Statewide Emergency Shelter Plan**

**WASHINGTON**

Name	Bldg. #	Address	City	Zip	Retrofitted (R) or New Construction (N)	General (G), PSN (P), Pet-Friendly (A)	Total Risk Capacity In People <i>(Meets ARC 4496)</i>	Total Risk Capacity (ft <sup>2</sup> ) <i>(Meets ARC 4496)</i>	Risk Capacity In People <i>(Does not Meet ARC 4496)</i>	Local Planned usage (reported capacity)	Funding Source: Local (L), State (S), Federal (F), and Program Name	Comments
Chipley High School/Rouhlac Middle	5	1535 Brickyard Road	Chipley	32428	R	G	154	3,314		154	S-1523	Updated FISH Data
Chipley High School/Rouhlac Middle	6	1535 Brickyard Road	Chipley	32428	R	G	453	10,956		453	S-1523	Updated FISH Data
Chipley High School/Rouhlac Middle	7	1535 Brickyard Road	Chipley	32428	R	G	224	5,600		162	S-1523	Updated FISH Data
Chipley High School/Rouhlac Middle	8	1535 Brickyard Road	Chipley	32428	N	G	153	2,729		153		Updated FISH Data
Chipley High School/Rouhlac Middle	2	1535 Brickyard Road	Chipley	32428	R	G	245	5,619		245	S-1523	Updated FISH Data
Chipley High School/Rouhlac Middle	1	1535 Brickyard Road	Chipley	32428	R	G	69	1,037		132	1588-2006	Updated FISH Data
Chipley High School/Rouhlac Middle	3	1535 Brickyard Road	Chipley	32428	R	G	438	7,086		438	1588-2006	Updated FISH Data
Vernon High School	1	3232 Moss Hill Road	Vernon	32462	R	G	181	3,616	0		L	Updated FISH Data
Vernon High School	2	3232 Moss Hill Road	Vernon	32462	R	G	89	1,775			L	Updated FISH Data
Vernon High School	3	3232 Moss Hill Road	Vernon	32462	N	G	469	9,377			L	Updated FISH Data
Vernon High School	4	3232 Moss Hill Road	Vernon	32462	N	G	239	4,786			L	Updated FISH Data
Vernon High School	5	3232 Moss Hill Road	Vernon	32462	R	G	300	5,996			L	Updated FISH Data
Vernon High School	6	3232 Moss Hill Road	Vernon	32462	N	G	166	3,323			L	Updated FISH Data
Vernon High School	7	3232 Moss Hill Road	Vernon	32462	R	G	136	2,711			L	Updated FISH Data
Vernon High School	8	3232 Moss Hill Road	Vernon	32462	R	G	126	2,527			L	Updated FISH Data
Vernon Middle School	2	3206 Moss Hill Road	Vernon	32462	R	G	208	3,147		208	S-1523	Updated FISH Data
Vernon Middle School	3	3206 Moss Hill Road	Vernon	32462	R	G	405	7,053		405	S-1523	Updated FISH Data
Vernon Middle School	4	3206 Moss Hill Road	Vernon	32462	R	G	301	7,299		301	S-1523	Updated FISH Data
Vernon Middle School	5	3206 Moss Hill Road	Vernon	32462	R	G	280	5,844		280	S-1523	Updated FISH Data
Washington County Ag Center		800 W Washington Avenue	Chipley	32428			0	0	0			

**TOTALS FOR WASHINGTON COUNTY**

<b>4,636</b>	<b>93,795</b>	<b>0</b>	<b>2,931</b>	<b>0</b>
--------------	---------------	----------	--------------	----------

Year 2012	Shelter Capacity In People	Shelter Demand In People	Surplus/ Deficit In People	Shelter Capacity (ft2)	Surplus/ Deficit (ft2)	Result
Storm Category 4/5	4,636	1,476	3,160	93,795	64,275	

**Special Needs Storm Shelters**

Name	Bldg. #	Address	City	Zip	SpNS Capacity (spaces @ 60sf) (meets ARC 4496)	SpNs Capacity (sf) (meets ARC 4496)	SpNS Capacity (spaces @ 60sf) (does not meet ARC 4496)	Local Planned usage (reported capacity)	Funding Source: Local (L), State (S), Federal (F), and Program Name	Comments	
Rouhlac MS	12 (New EHPA 5th Grade)	1535 Brickyard Rd	Chipley	32428		P	144	8,666	0		Updated FISH Data

Year 2012	SpNs Shelter Capacity In Spaces (meets ARC 4496)	SpNs Shelter Demand In Spaces	Surplus/ Deficit In Spaces	SpNs Shelter Capacity (ft2)	Surplus/ Deficit (ft2)	Result
Storm Category 4/5	144	100	44	8,640	2,640	

## **Appendix B**

*2010 Florida Building Code—Building*  
Section 423.25 Public Shelter Design Criteria

## **Public Shelter Design Criteria.**

423.25 Public shelter design criteria.

423.25.1 New facilities. New educational facilities for school boards and Florida college boards, unless specifically exempted by the board with the written concurrence of the applicable local emergency management agency or the Department of Community Affairs (DCA), shall have appropriate areas designed as enhanced hurricane protection areas (EHPAs) in compliance with this section.

Exception: Facilities located, or proposed to be located, in a Category 1, 2, or 3 evacuation zone shall not be subject to these requirements.

423.25.1.1 Enhanced hurricane protection areas (EHPA). The EHPA areas shall provide emergency shelter and protection for people for a period of up to 8 hours during a hurricane.

423.25.1.1.1 The EHPA criteria apply only to the specific portions of (K-12) and Florida college educational facilities that are designated as EHPAs.

423.25.1.2 The EHPAs and related spaces shall serve the primary educational or auxiliary use during non-shelter occupancy.

423.25.2 Site. Factors such as low evacuation demand, size, location, accessibility and storm surge may be considered by the board, with written concurrence of the local emergency management agency or the DCA, in exempting a particular facility.

423.25.2.1 Emergency access. EHPAs shall have at least one route for emergency vehicle access. The emergency route shall be above the 100-year floodplain. This requirement may be waived by the board, with concurrence of the local emergency management agency or the DCA.

423.25.2.2 Landscaping. Landscaping around the EHPAs shall be designed to preserve safety and emergency access. Trees shall not conflict with the functioning of overhead or underground utility lines, or cause laydown or impact hazard to the building envelope.

423.25.2.3 Parking. During an emergency condition, vehicle parking shall be prohibited within 50 feet (15 240 mm) of an EHPA. Designated EHPA parking areas may be unpaved.

423.25.2.4 Signage. Floor plans of the facility, indicating EHPAs, shall be mounted in the emergency manager's office/area.

423.25.3 Design. EHPAs may be above or below ground and may have more than one story, provided the design satisfies the wind load and missile impact criteria. Modular and open-plan buildings may serve as EHPAs provided the design satisfies the wind load and missile impact criteria.

423.25.3.1 Excluded spaces. Spaces such as mechanical and electrical rooms, storage rooms, open corridors, kitchens, science rooms and labs, vocational shop areas and labs, computer rooms, attic and crawl spaces shall not be used as EHPAs.

423.25.3.2 Capacity. Fifty percent of the net square feet of a designated educational facility shall be constructed as EHPAs. The net square feet shall be determined by subtracting from the gross square feet those spaces, such as mechanical and electrical rooms, storage rooms, open corridors, kitchens, science rooms and labs, vocational shop areas and labs, computer rooms, attic and crawl spaces that shall not be used as EHPAs. The board, with concurrence of the applicable local emergency management agency or DCA, may adjust this requirement if it is determined to be in its best interest. The capacity of an EHPA shall be calculated at 20 square feet (2 m<sup>2</sup>) per occupant (adults and children five years or older).

423.25.3.3 Toilets. Toilet and hand washing facilities should be located within the EHPAs and provided at one toilet and one sink per 40 occupants. These required toilet and hand-washing facilities are not in addition to those required for normal school occupancy and shall be included in the overall facility fixture count.

423.25.3.3.1 Support systems for the toilets, e.g., bladders, portable toilets, water storage tanks, etc., shall be capable of supplying water and containing waste, for the designed capacity of the EHPAs.

423.25.3.3.2 Plumbing and valve systems of "normal" toilets within the EHPAs may be designed for conversion to emergency operation to meet the required demand.

423.25.3.4 Food service. Where feasible, include counter tops for food distribution functions in the EHPAs.

423.25.3.5 Manager's office. An administration office normally used by a school administrator shall be identified as the EHPA manager's office and shall be located within the EHPA. The office shall have provisions for standby power, lighting, communications, main fire alarm control panel and storage for the manager's equipment.

423.25.4 Structural standard for wind loads. At a minimum, EHPAs shall be designed for wind loads in accordance with ASCE 7, Minimum Design Loads for Buildings and Other Structures, Risk Category IV-(Essential Buildings) . Openings shall withstand the impact of wind-borne debris missiles in accordance with the impact and cyclic loading criteria per ASTM E-1886 and ASTM E-1996-or SBC/SSTD 12. Based on a research document, Emergency Shelter Design Criteria for Educational Facilities, by the University of Florida for the DOE, it is highly recommended by the department that the shelter be designed using the map wind speed plus 40 mph.

423.25.4.1 Missile impact criteria. The building enclosure, including walls, roofs, glazed openings, louvers and doors, shall not be perforated or penetrated by a flying object. For

walls and roofs, the missile criteria are as provided in ASTM E-1886 and ASTM E-1996 or SBC/SSTD 12.

423.25.4.1.1 Materials used for walls, roofs, windows, louvers, and doors shall be certified for resistance to missile impact criteria.

423.25.4.1.2 The glazed openings or permanent protective systems over glazed openings shall be designed for cyclic loading.

423.25.4.2 Roofs. Roof decks shall be cast-in-place 4-inch (102 mm) or more, normal weight concrete. Concrete decks shall be waterproof. Systems other than cast-in-place concrete shall have adequate bearing, anchorage against wind uplift, diaphragm action, and resistance to rain that are equivalent to a cast-in-place system.

Exception: Structural precast concrete roofs, composite metal decks with normal weight concrete roofs, or other systems and materials that meet the wind load and missile impact criteria may be used.

423.25.4.2.1 Light weight concrete or insulating concrete may be used on roof decks of EHPAs provided the roof decks are at least 4-inch (102 mm) cast-in-place normal weight concrete or other structural systems of equivalent strength.

423.25.4.2.2 Roof openings (e.g., HVAC fans, ducts, skylights) shall be designed to meet the wind load and missile impact criteria.

423.25.4.2.3 Roof coverings shall be specified and designed according to the latest ASTM and Factory Mutual Standards for materials and wind uplift forces. Roofs shall be inspected by a licensed engineer/architect and a representative of the roofing manufacturer.

423.25.4.2.4 Roofs shall have adequate slope and drains sized for normal use and shall have emergency overflow.

423.25.4.2.5 Parapets shall satisfy the wind load and missile impact criteria; roof overhangs shall resist uplift forces.

423.25.4.3 Windows. All unprotected window assemblies and their anchoring systems shall be designed and installed to meet the wind load and missile impact criteria.

423.25.4.3.1 Windows may be provided with permanent protective systems, provided the protective system is designed and installed to meet the wind load and missile impact criteria and completely covers the window assembly and anchoring system.

423.25.4.3.2 EHPAs shall have mechanical ventilation systems. Ventilation shall be provided at a minimum rate of 2 cfm per square foot of EHPA floor area. The mechanical ventilation system shall be connected to the EHPA's emergency power.

423.25.4.4 Doors. All exterior and interior doors subject to possible wind exposure and/or missile impact shall have doors, frames, anchoring devices, and vision panels designed and installed to resist the wind load and missile impact criteria or such doors, frames, anchoring devices, and vision panels shall be covered with permanent protective systems designed and installed to resist the wind load and missile impact criteria.

423.25.4.5 Exterior envelope. The exterior envelope, louvers over air intakes and vents, and gooseneck type intakes and vents of EHPAs shall be designed and installed to meet the wind load and missile impact criteria.

423.25.4.5.1 HVAC equipment mounted on roofs and anchoring systems shall be designed and installed to meet the wind load criteria.

423.25.4.5.2 Roof mounted HVAC equipment shall have a 12-inch-high (305 mm) curb around the roof opening and be designed to prevent the entry of rain water.

423.25.4.6 Foundations and floor slabs. Foundations shall be designed to resist all appropriate loads and load combinations, including overturning moments due to wind. The floor elevation and necessary life safety and other emergency support systems of EHPAs shall be elevated above the maximum storm surge inundation elevation associated with a Category 4 hurricane event. Storm surge elevations shall be identified by the most current edition of the regional Sea Lake and Overland Surges from Hurricanes (SLOSH) studies and atlases.

423.25.5 Electrical and standby emergency power system. The EHPA shall be provided with a standby emergency electrical power system, per Chapter 27, NFPA 70 Articles 700 and 701, which shall have the capability of being connected to a backup generator or other optional power source. Where economically feasible, an equivalent photovoltaic system may be provided. The EHPA's emergency systems includes, but are not limited to: (1) an emergency lighting system, (2) illuminated exit signs, (3) fire protection system(s), alarm (campus wide) and sprinkler, and (4) minimum ventilation for health/safety purposes. The fire alarm panel shall be located in the EHPA manager's office. A remote annunciator panel shall be located in or adjacent to the school administrator's office. When generators are installed, the facility housing the generator, permanent or portable, shall be an enclosed area designed to protect the generators from wind and missile impact. Air intakes and exhausts shall be designed and installed to meet the wind load and missile impact criteria. Generators hardened by the manufacturer to withstand the area's design wind and missile impact criteria shall be exempt from the enclosed area criteria requirement.

423.25.5.1 EHPA lighting. Emergency lighting shall be provided within the EHPA area, EHPA manager's office, toilet rooms, main electrical room and generator spaces and shall be at least 10 footcandles (100 lux) of general illumination, which can be reduced to 1/2 footcandle (5 lux) in the sleeping areas during the night.



423.25.5.2 Optional standby circuits. Additional nonlife safety systems, as defined by Chapter 27, NFPA 70 Article 702 (optional standby circuits), may be supplied power, if available, by the Standby Emergency Power System. These systems shall be connected to the Standby Emergency Power System via an electrical subpanel to the Standby Electrical Power System's main electrical panel. This will allow selective or total load shedding of power if required. The fire alarm, emergency lighting and illuminated exit signs throughout the entire campus shall receive first priority to power provided by the Standby Emergency Power System per Chapter 27, NFPA 70 Article 700. The systems listed are not all encompassing but are in order of priority. Local officials may request additional non-life safety systems they deem necessary for health, welfare and safety of the public during occupancy:

1. Remainder of the school's campus security lighting (building and site).
2. Additional ventilation systems within the EHPA, including heat.
3. Intercom system.
4. Food storage equipment.
5. Additional electric receptacles, other than those required by Section 423.25.5.3.

423.25.5.3 Receptacle outlets. A minimum of four electrical outlets, served with power from the standby circuits, shall be provided in the EHPA manager's office.

423.25.6 Inspections. EHPAs shall be considered "threshold buildings" in accordance with Section 553.71(7), Florida Statutes, and shall comply with Sections 553.79(5), 553.79(7), and 553.79(8), Florida Statutes.

423.25.6.1 Construction of EHPAs shall be inspected during the construction process by certified building code inspectors or the design architect/engineer(s) certified pursuant to Part XII Chapter 468, Florida Statutes and threshold inspectors for compliance with applicable rules and laws.

423.25.6.2 The emergency electrical systems shall be inspected during the construction process by certified electrical inspector or Florida-registered professional engineers certified pursuant to Part XII Chapter 468, Florida Statutes, skilled in electrical design.

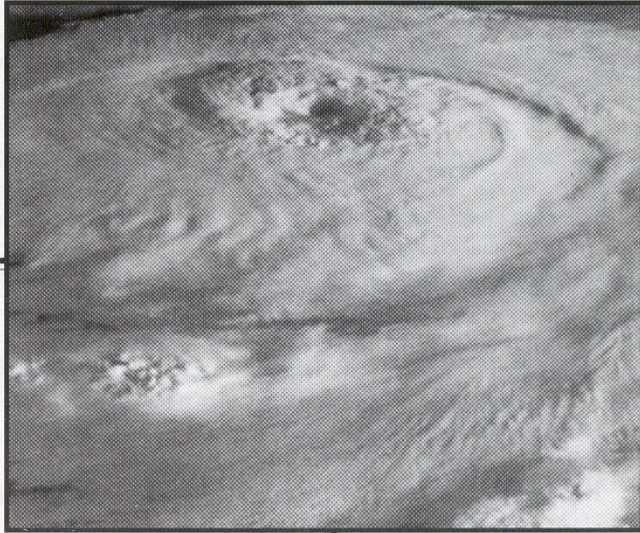
423.25.6.3 EHPAs shall be inspected and recertified for compliance with the structural requirements of this section every five years by a Florida-registered professional engineer skilled in structural design. If any structural system, as specified in this section, is damaged or replaced, the recertification shall be obtained prior to the beginning of the next hurricane season.

423.25.6.4 All shutter systems, roofs, overflow scuppers, and structural systems of EHPAs shall be inspected and maintained annually prior to hurricane season and after a

major event. All emergency generators shall be inspected under load conditions including activation of the fire alarms, emergency lights as per applicable equipment codes and NFPA standards, and including mechanical systems and receptacles connected to the emergency power.

## **Appendix C:**

Standards for Hurricane Evacuation Shelter Selection (ARC 4496, Rev. 2002)



*Standards  
for  
Hurricane  
Evacuation  
Shelter  
Selection*



*Together, we can save a life*



An interagency group comprised of the Federal Emergency Management Agency, the U.S. Army Corps of Engineers, the Environmental Protection Agency and Clemson University, has developed hurricane evacuation shelter selection standards. These standards reflect the application of technical data compiled in hurricane evacuation studies, other hazard information, and research findings related to wind loads and structural problems. These standards are supplemental to information contained in ARC 3041, *Mass Care: Preparedness and Operations* concerning shelter selection.

Planning considerations for hurricane evacuation shelters involve a number of factors and require close coordination with local officials responsible for public safety. Technical information contained in Hurricane Evacuation Studies, storm surge and flood mapping, and other data can now be used to make informed decisions about the suitability of shelters.

In the experience of the American Red Cross, the majority of people evacuating because of a hurricane threat generally provide for themselves or stay with friends and relatives. However, for those who do seek public shelter, safety from the hazards associated with hurricanes must be assured. These hazards include—

- Surge inundation.
- Rainfall flooding.
- High winds.
- Hazardous materials.

**The following standards address the risks associated with each of these hurricane-associated hazards.**

### **Surge Inundation**

In general, hurricane evacuation shelters should not be located in areas vulnerable to hurricane surge inundation. The National Weather Service has developed mathematical models, such as Sea, Lake, and Overland Surges from Hurricanes (SLOSH) and Special Program to List Amplitudes of Surges from Hurricanes (SPLASH), that are critical in determining the potential level of surge inundation in a given area.

- Carefully review inundation maps in order to locate all hurricane evacuation shelters outside of Category 4 storm surge inundation zones.
- Avoid buildings subject to isolation by surge inundation in favor of equally suitable buildings not subject to isolation. Confirm that ground elevations for all potential shelter facilities and access routes obtained from topographic maps are accurate.
- Do not locate hurricane evacuation shelters on barrier islands.

### **Rainfall Flooding**

Rainfall flooding must be considered in the hurricane evacuation shelter selection process. Riverine inundation areas shown on Flood Insurance Rate Maps (FIRMs), as prepared by the National Flood Insurance Program, should be reviewed. FIRMs should also be reviewed in locating shelters in inland counties.

- Locate hurricane evacuation shelters outside the 100-year floodplain.
- Avoid selecting hurricane evacuation shelters located within the 500-year floodplain.
- Avoid selecting hurricane evacuation shelters in areas likely to be isolated due to riverine inundation of roadways.
- Make sure a hurricane evacuation shelter's first floor elevation is on an equal or higher elevation than that of the base flood elevation level for the FIRM area.
- Consider the proximity of shelters to any dams and reservoirs to assess flow upon failure of containment following hurricane-related flooding.



## High Winds

Consideration of any facility for use as a hurricane evacuation shelter must take into account wind hazards. Both design and construction problems may preclude a facility from being used as a shelter. Local building codes are frequently inadequate for higher wind speeds.

- If possible, select buildings that a structural engineer has certified as being capable of withstanding wind loads according to ASCE (**American Society of Engineers**) 7-98 or ANSI (**American National Standards Institute**) A58 (1982) structural design criteria. Buildings must be in compliance with all local building and fire codes.
- Failing a certification (see above), request a structural engineer to rank the proposed hurricane evacuation shelters based on his or her knowledge and the criteria contained in these guidelines.
- Avoid uncertified buildings of the following types:
  - Buildings with long or open roof spans longer than 40 feet.
  - Unreinforced masonry buildings.
  - Pre-engineered (steel pre-fabricated) buildings built before the mid-1980s.
  - Buildings that will be exposed to the full force of hurricane winds.
  - Buildings with flat roofs or built with lightweight materials.
- Give preference to the following:
  - Buildings with 10°-30° pitched, hipped roofs; or with heavy concrete roofs.
  - Buildings no more than 60 feet high.
  - Buildings in sheltered areas (protected from strong winds).
  - Buildings whose access routes are not tree-lined.

## Hazardous Materials

The possible impact from a spill or release of hazardous materials should be taken into account when considering any potential hurricane evacuation shelter.

All facilities manufacturing, using, or storing hazardous materials (in reportable quantities) are required to submit *Material Safety Data Sheets* (emergency and hazardous chemical inventory forms) to the Local Emergency Planning Committee (LEPC) and the local fire department. These sources can help you determine the suitability of a potential hurricane evacuation shelter or determine precautionary zones (safe distances) for facilities near potential shelters that manufacture, use or store hazardous materials.

- Facilities that store certain reportable types or quantities of hazardous materials may be inappropriate for use as hurricane evacuation shelters.
- Hurricane evacuation shelters should not be located within the ten-mile emergency planning zone (EPZ) of a nuclear power plant.
- Chapters must work with local emergency management officials to determine if hazardous materials present a concern for potential hurricane evacuation shelters.

## Interior Building Safety Criteria During Hurricane Conditions

Based on storm data (e.g., arrival of gale-force winds), determine a notification procedure with local emergency managers regarding when to move the shelter population to pre-determined safer areas within the facility. Consider the following:

- Do not use rooms attached to, or immediately adjacent to, unreinforced masonry walls or buildings.
- Do not use gymnasiums, auditoriums, or other large open areas with long roof spans (longer than 40 feet) during hurricane conditions.
- Avoid areas near glass unless an adequate shutter protects the glass surface. Assume that windows and the roof will be damaged and plan accordingly.
- Use interior corridors or rooms.
- In multi-story buildings, use only the lower floors (no higher than 60 feet) and avoid corner rooms.
- Avoid any wall section that has portable or modular classrooms in close proximity, if these are used in your community.
- Avoid basements if there is any chance of flooding.



## Least-Risk Decision Making

Safety is the primary consideration for the American Red Cross in selecting hurricane evacuation shelters. When anticipated demands for hurricane evacuation shelter spaces exceed existing capacity as defined by the preceding standards, there may be a need to utilize less preferred facilities. It is critical that shelter selection decisions be made carefully and in consultation with local emergency management and public safety officials. This process should include the following considerations:

- No hurricane evacuation shelter should be located in an evacuation zone for obvious safety reasons. All hurricane evacuation shelters should be located outside of Category 4 storm surge inundation zones. Certain exceptions may be necessary, but only if there is a high degree of confidence that the level of wind, rain, and surge activities will not surpass established shelter safety margins.
- When a potential hurricane evacuation shelter is located in a flood zone, it is important to consider its viability. By comparing elevations of sites with FIRMs, one can determine if the shelter and a major means of egress are in any danger of flooding. Zone AH (within the 100-year flood plain and puddling of 1-3 feet expected) necessitates a closer look at the use of a particular facility as a sheltering location. Zones B, C, and D may allow some flexibility. It is essential that elevations be carefully checked to avoid unnecessary problems.
- In the absence of certification or review by a structural engineer, any building selected for use as a hurricane evacuation shelter must be in compliance with all local building and fire codes. Certain exceptions may be necessary, but only after evaluation of each facility, using the aforementioned building safety criteria.
- The Red Cross uses the planning guideline of 40-square feet of space per shelter resident. During hurricane conditions, on a short-term basis, shelter space requirements may be reduced. Ideally, this requirement should be determined using no less than 15 square feet per person. Adequate space must be set aside for registration, health services, and safety and fire considerations. Disaster Health Services areas should still be planned using a 40-square feet per person calculation. On a long-term recovery basis, shelter space requirements should follow guidelines established in ARC 3041, *Mass Care: Preparedness and Operations*.

## Hurricane Evacuation Shelter Selection Process

General procedures for investigating the suitability of a building or facility for use as a hurricane evacuation shelter are as follows:

- Identify viable sites. Evacuation and transportation route models must be considered.
- Complete a risk assessment on each viable site. Gather all pertinent data from SLOSH and/or SPLASH (storm surge), FIRM (flood hazard) models; determine the facility base elevation; and obtain hazardous materials information and previous studies concerning each building's suitability.
- Have a structural engineer evaluate the facility and rate its ability to withstand wind loads according to ASCE 7-98 or ANSI A58 (1982) structural design criteria.
- Inspect the facility and complete a *Red Cross Facility Survey* (ARC Form 6564) and a *Self-Inspection Work Sheet/Off Premises Liability Checklist*, in accordance with ARC 3041. Note all potential liabilities and the type of construction. Consider the facility as a whole. One weak section may seriously jeopardize the integrity of the building.

## Increasing Shelter Inventory

An annual review of all approved hurricane evacuation shelters is required. Facility improvements, additions, or deterioration may change the suitability of a selected facility as a hurricane evacuation shelter. Facility enhancements may also enable previously unacceptable facilities to be used as hurricane evacuation shelters.

Work with officials, facility managers, and school districts on mitigation opportunities. Continue to advocate that the building program for new public buildings, such as schools, should include provisions to make them more resilient to possible wind damage. Suggest minor modifications of municipal, community, or school buildings, such as the addition of hurricane shutters, while buildings are being planned. Such modifications will make them useful as hurricane evacuation shelters.

Finally, add any new shelters to chapter shelter system and disaster response plans. Share shelter information with local emergency planning partners and the state lead chapter for Disaster Services for inclusion in state disaster response plans.

Appendix D:  
Acronyms



### **Appendix D: Acronyms**

**ADA** – American Disabilities Act

**AMSL** – Above Mean Sea Level

**ANSI** – American National Standards Institute

**ARC** – American Red Cross

**ARC 3041** – ARC publication *Mass Care - Preparedness and Operations*

**ARC 4496** – ARC publication *Standards for Hurricane Evacuation Shelter Selection*

**ASCE** – American Society of Civil Engineers

**ASCE 7** – ASCE publication *Minimum Design Loads for Buildings and Other Structures*

**ASCE 24** – ASCE publication *Flood Resistant Design and Construction*

**ASTM** – American Society for Testing and Materials

**ASTM E 1886 and E 1996** – ASTM standards for windborne debris impact

**BEBR** – Bureau of Economic and Business Research (University of Florida)

**CFK** – Classroom for Kids (school capital outlay program)

**DEM** – Division of Emergency Management

**DOE** – Department of Energy (U.S.)

**DOE-STD-1020** – U.S. Department of Energy publication – *Natural Phenomena Hazards Design and Evaluation Criteria*

**EHPA** – Enhanced Hurricane Protection Area

**FBC** – Florida Building Code

**FLDOE** – Florida Department of Education

## **Acronyms (Continued)**

**FEMA** – Federal Emergency Management Agency

**FISH** – Florida Inventory of School Houses

**FIRM** – Flood Insurance Rate Map

**Fla.Stat.** – Florida Statutes

**FNSS** – Functional Needs Support Services

**GP** – General Population (Shelter)

**HMG** – Hazard Management Group, Inc.

**HMGP** – Hazard Mitigation Grant Program

**ICF** – Insulated Concrete Form

**ICC** – International Code Council

**K-12 (School)** – Kindergarten to High School Grade 12

**LEPC** - Local Emergency Planning Committee

**LiDAR** – Light Detection and Ranging

**NHC** - National Hurricane Center

**NWS** - National Weather Service

**PC** – Performance Category (DOE-STD-1020)

**PDM** – Pre-Disaster Mitigation grant program

**PECO** – Public Education Construction Outlay

**Acronyms (Continued)**

**PSN** – Persons with Special Needs

**RPC** – Regional Planning Council

**RF** – Reduction Factor

**SIT** – School Infrastructure Thrift Award

**SLOSH** – Sea, Lake, and Overland Surges from Hurricanes

**SpNS** – Special Needs Shelter

**Sq.Ft.** – Square Feet (Area Quantity Dimension)

**SREF** – State Requirements for Educational Facilities

**SREs** – Statewide Regional Evacuation Study

**SSTD 12** – Southern Building Code Congress International - Standard 12 - *Test Standards for Determining Resistance From Windborne Debris*

**TAS** – Testing Application Standard

**VS** – Vulnerability Zone (Hazardous materials)

## **Appendix E:**

### Glossary

## Appendix E: Glossary

**Accessibility:** A site, building, facility, or portion thereof that complies with the *ADA Accessibility Guidelines for Building and Facilities (Code of Federal Regulations 28 CFR Part 36)* and/or the *Florida Accessibility Code for Building Construction (Florida Building Code—Building, Chapter 11)*.

**Barrier Island (Coastal):** Geological features which lie above the line of mean high water and are completely surrounded by open marine waters and that front upon the Gulf of Mexico, Atlantic Ocean, Florida Bay or Straits of Florida; reference §161.54(2), Florida Statutes.

**Board:** Unless otherwise specified, means a district school board, a community college board of trustees, a university board of trustees. The term "board" does not include the State Board of Education.

**Core Area:** Portion(s) within a facility enclosed within one or more layers of walls, partitions, ceilings, roofs, aperture assemblies, screens, barriers or baffling that when analyzed as a unit can protect occupants from specified external hazard(s).

**Critical Support Systems:** Structures, systems and components required to ensure the health, safety and well-being of occupants. Critical support systems include, but not limited to, life-safety systems, potable and waste water systems, electrical power systems and heating, ventilation and air-conditioning (HVAC) systems.

**Educational Facilities:** Means the buildings and equipment, structures, and special educational use areas that are built, installed, or established to serve primarily the educational purposes and secondarily the social and recreational purposes of the community and which may lawfully be used as authorized by the Florida Statutes and approved by boards.

**Enhanced Hurricane Protection Area:** A new educational facility or portion thereof that is designed, constructed and inspected in accordance with the Public Shelter Design Criteria, section 423.25, *Florida Building Code—Building*.

**Evacuation Shelter:** A safe congregate care facility that provides essential support services and is utilized for populations displaced by an emergency or disaster event. Evacuation shelters are typically used for durations of less than 72 hours during and immediately following the emergency or disaster event causing their need. An evacuation shelter may be located either inside or outside of the disaster impact area. See Risk Evacuation Shelter and Host Evacuation Shelter.

**Glossary (continued)**

**Evacuation Zone (Hurricane):** Area(s) designated to be evacuated for particular hurricane scenarios to protect an at-risk population from flooding or high winds. Evacuation zones are developed taking into consideration all populated areas having a serious risk of flooding, areas not subject to flooding but may be cut-off or completely surrounded and isolated by flooded areas, and the need to be easily communicated to the public.

**Excluded Space:** Spaces such as mechanical, plumbing, electrical and telecommunication equipment rooms, storage rooms and closets, exterior/outside circulation and corridors, restrooms and shower areas, kitchen and food preparation rooms, science labs, computer and information technology labs, vocational and industrial technology labs and shops, library and media rooms and labs, administrative office and support areas, record vaults, attics and crawl spaces.

**Functional and Access Needs Population(s):** Groups whose needs are not fully addressed by the traditional service providers. This includes groups that may feel they cannot comfortably or safely access and use the standard resources offered in disaster preparedness, response, and recovery. This includes, but is not limited to: those who have a physical and/or mental disability (blind, cognitive disorders, mobility limitations, deaf and/or hard of hearing, etc); Limited or non-English speaking; medically or chemically dependent; geographically and/or culturally isolated; Frail elderly, and children.

**Functional Needs Support Services:** Services that enable children and adults to maintain their usual level of independence in a general population shelter. FNSS includes reasonable modifications to policies, practices and procedures, durable medical equipment, consumable medical supplies, personal assistance services and other goods and services as needed. Children and adults requiring FNSS may have physical, sensory, mental health, cognitive and/or intellectual disabilities affecting their ability to function independently without assistance.

**Host Evacuation Shelter:** A facility that is relatively safe and provides essential support services. Facilities are designated as Host Shelters when they are located outside the projected path of an approaching hurricane or severe storm. As local conditions are not expected to present hazards such as surge inundation, rainfall flooding, high winds, or hazardous materials which exceed the building codes of the facilities, shelter selection guidelines in ARC 4496 do not have to be considered. For planning purposes, the operational period of a Host Shelter is from 24 hours prior to landfall until 72 hours after landfall of a hurricane or severe storm.

**Included Space:** All rooms and areas not listed in the definition of excluded space.

## Glossary (continued)

**Long Span (Roof):** See Open Span.

**Long-Term Shelter:** A safe congregate care facility that provides essential support services and is utilized for durations typically longer than two (2)-weeks for populations displaced by an emergency or disaster event.

**Mega-Shelter:** An arena, stadium, convention center or similar high-occupancy facility that is used to shelter an exceptionally large population of evacuees from a major disaster. Mega-shelters are often designed, planned or designated to accommodate more than 5,000 evacuees in dormitory areas at the same time. A mega-shelter may be used at any time in the emergency cycle (evacuation, response and recovery), and may be located inside or outside of the disaster impact area.

**Mitigation:** Actions taken to prevent or reduce the risk to life, property, social, economic activities, and natural resources from natural or technological hazards.

**Net Usable Floor Area:** The floor area of included spaces reduced to account for partitions and walls, columns, fixed or movable objects, furniture, equipment or other features that under probable conditions cannot be removed or stored during use as a shelter.

**New Construction:** Means any construction of a building or unit of a building in which the entire work is new or an entirely new addition connected to an existing building or which adds additional square footage to the space inventory.

**On-site:** Means either inside, immediately adjacent to, or on the same site and under the control of the owner or lawful tenant.

**Open Span (Roof):** An area in a structure where the clear distance between supporting elements (beams, columns, etc.) in the shortest direction is 40 feet or more.

**Person with Special Needs:** Someone, who during periods of evacuation or emergency, requires sheltering assistance, due to physical impairment, mental impairment, cognitive impairment, or sensory disabilities. See Rule 64-3.010(1), Florida Administrative Code.

**Reduction Factor:** Factors used to reduce the net floor area in order to accommodate presence of exterior and interior walls, furnishings, equipment, walkways, etc., resulting in the net usable floor area.

**Glossary (continued)**

**Remodeling:** Means the changing of existing facilities by rearrangement of spaces and their use and includes, but is not limited to, the conversion of two classrooms to a science laboratory or the conversion of a closed plan arrangement to an open plan configuration.

**Renovation:** Means the rejuvenating or upgrading of existing facilities by installation or replacement of materials and equipment and includes, but is not limited to, interior or exterior reconditioning of facilities and spaces; air-conditioning, heating, or ventilating equipment; fire alarm systems; emergency lighting; electrical systems; and complete roofing or roof replacement, including replacement of membrane or structure.

**Retrofit:** Modifications performed upon an existing structure or infrastructure with the goal of significantly reducing or eliminating potential damage due to a specific hazard.

**Risk Evacuation Shelter:** A facility that is relatively safe and provides essential support services. Facilities designated as Risk Evacuation Shelters lie within or near the forecast path and associated error cone of an approaching hurricane or severe storm. As local conditions may present hazards such as storm surge inundation, rainfall flooding, high winds, or hazardous materials which may exceed the building codes of the facility, shelter selection guidelines in ARC 4496 do need to be considered. The designation does not imply that a facility is capable of affording complete protection or is free from hazards but only that it meets established minimum safety criteria.

**Saffir-Simpson Hurricane Scale:** The current prevalent system of classifying hurricanes based on five categories that relate hurricane strength and, therefore, damage potential, with the central pressure, wind velocity, and storm surge.

**Short-Term Shelter:** A safe congregate care facility that provides essential support services and is utilized for durations of less than two (2) weeks for populations displaced by an emergency or disaster event. Also referred to as Standard Shelter.

**Shelter:** A designated place or building of relative safety that temporarily provides essential support services with the goal of preserving life and reducing human suffering.

**Shelter Envelope:** Vertical and horizontal materials and assemblies that enclose a shelter area and serve as protective barriers from hurricane wind and debris hazards. The shelter envelope includes roof coverings, roof assembly, roof top vent & equipment penetrations for assemblies, exterior walls, door and window assemblies, glazing, skylight assemblies, louvers and where applicable floor and interior wall assemblies that separate the shelter from unprotected areas of a host building.



## **Glossary (continued)**

**Shutters:** Permanent or temporary closures or shields and assemblies that serve as a structural barrier to resist wind induced loads that act on their surface(s) to include aerodynamic and wind-borne debris impact loads.

**Site:** The spatial location of existing or planned facility(s), ancillary structures and utilities, improvements and surrounding environment. A space of ground occupied or to be occupied by a facility or program.

**SLOSH modeling:** A modeling methodology developed by the National Weather Service/ National Hurricane Center that predicts the maximum envelope and depth of coastal and inland storm surge inundation with respect to categories of hurricane intensity.

**Special Needs Clients:** See Person with Special Needs.

**Special Needs Shelters (SpNS):** Locations that are, in whole or in part, designated under Chapter 252, F.S., to provide shelter and services to persons with special needs who have no other option for sheltering. These shelters are designated to have back-up generator power. Special needs shelter services are to minimize deterioration of pre-event levels of health. See Rule 64-3.010(10), Florida Administrative Code.

**Storm Surge:** An abnormal rise in water level at the shoreline of a large body of water caused by wind and pressure forces of a storm or hurricane.

**Standard Shelter:** See Short-Term Shelter.

**Appendix F:**

Mass Care Standards and Indicators, Version 011-072209

# Mass Care Standards and Indicators

## Purpose

Normally the first assistance to be provided in a disaster is mass care services, which are intended to minimize the immediate, disaster-caused suffering of people through the provision of food, clothing, shelters and supplies. Based on the community, culture, economy and geography of the affected region and the scope of the disaster relief operation, service providers will determine the most effective service delivery strategies for meeting the needs of those affected. This service is provided regardless of ethnicity, religion, citizenship, age, gender, disability, economic status, or sexual orientation. Fundamental to the responsibilities of providing assistance is listening to and observing the needs of individuals and families and facilitating referrals for other activities such as health services and mental health services.

## Services

Service provision is made available through one or more of five integrated elements:

- (1) individual or congregate temporary shelters
- (2) fixed or mobile feeding operations
- (3) distribution of relief supplies
- (4) health and / or mental health services
- (5) information on recovery assistance

## Process

Immediate needs are characterized as physical, emotional and informational. The first priority is to determine when and where mass care services are to be provided. The first stage of the response usually begins at the community level. At a minimum, those involved undertake the necessary activities to accommodate the immediate needs in the earliest hours and days until additional help arrives. This requires coordination at all levels, and a concerted effort is needed to maintain communication prior to, in the event of and post disaster. These immediate needs may include any or all of the following:

### *Physical needs*

- shelter (protection from harm and physical safety)
- space and materials for sleep
- food
- water
- health assessments and first aid
- durable medical equipment/medical supplies
- dietary needs
- recovery and clean-up supplies
- toiletries
- baby supplies

### *Emotional needs*

- emotional support and psychological first aid from staff
- establishment of structured routines
- opportunities for children and families to participate in their own recovery
- assistance from concerned staff
- opportunity to communicate their situation

### *Informational needs*

- status of disaster and relief efforts

- status of family members
- types of available assistance
- process of obtaining assistance
- accessible formats

## **Methods of Mass Care Service Delivery:**

### *Sheltering*

Shelters provide temporary housing for people displaced by disaster; in addition to temporary housing, residents may be supplied with emergency provisions, receive meals, and gather information on assistance and recovery. Shelter residents may also have access to health and mental health professionals.

### *Fixed sites*

Organizations determine at the time of the disaster, considering safety and accessibility, sites in the community where individuals and families affected by the disaster may receive food, distribution items, psychological first aid, health assessments including emergency first aid and/or welfare and recovery information.

### *Mobile units*

Organizations go out into communities affected by disaster to provide individuals and families with food, distribution items, emergency first aid, psychological first aid and/or welfare and recovery information, depending on the type of mobile unit being utilized.

The purpose of this section of the document is to provide benchmarks for organizations and common goals for service delivery. The standards and indicators defined below were developed in coordination with experienced practitioners from a wide range of organizations. This information is meant to be used as a tool and should not prevent an organization from providing Mass Care services. As a result of inter-agency collaboration, new tools are being developed to help organizations meet the needs of those affected by disaster.

### **Mass Care Standards and Indicators**

#### ***Sheltering:***

Shelters provide a safe place for individuals and families affected by a disaster and may offer, among other things, food, snacks, beverages, cots, blankets, sanitation facilities, safety and information on recovery efforts.

No persons seeking shelter will be denied services. Shelter workers will strive to accommodate those with disabilities. If a shelter is unable to provide accommodation, the shelter manager will assist in identifying alternatives and a referral will be made.

Shelter staff members abide by principles of confidentiality.

Shelters strive to be safe, secure spaces. Shelter management takes active measures to ensure the safety of those being assisted.

Shelters strive to protect the family unit by keeping family members together.

Shelters strive to accommodate the varying cultural and faith-based requirements of the residents. Such requirements could include variations in sleeping, eating and living spaces, and providing spaces to meet and honor spiritual needs.

Shelter facilities are selected, (pre-disaster, whenever possible) using the following standards and indicators:

Twenty square feet of personal sleeping space per person is designated for emergency short term (24-48 hrs) evacuation shelters and 40-60+ square feet of usable space per person for post disaster shelters.

Potable water is supplied in a sufficient amount to meet the needs of the shelter operations. Consideration should be given to additional supply demands created by cleaning, food service operations, laundry, drinking, bathing, and other hygiene purposes.

Toilets are provided at a number that prevents excessive wait times. In addition, sanitation and health considerations must be made to ensure that the facilities are fit for use. Supplement existing facilities with portable

units as necessary. On average one toilet for every 20 persons will meet the needs of the shelter population.

Adequate hand washing stations must be available to meet the health and sanitation needs of the shelter population. Hand washing stations should be located near toilet areas and equipped with soap, disposable towels and warm water if possible. Supplement existing facilities with portable units as necessary. On average one hand washing lavatory for every 20 persons will meet the needs of the shelter population.

Each shelter resident should have an opportunity to have a 15 minute shower once per day. Adequate facilities should be maintained to meet the demand. If showers are not available, provide transportation to another facility on a regular basis or supplement existing facilities with portable units as necessary. An approximate ratio of 1 shower for every 25 persons will meet this need.

Separate restroom facilities for each gender, which are well lit to ensure security.

Sewage or other disposal systems that can process at least 1.5 gallons of human waste per person per day.

Storage and removal of solid waste in the amount of 5 lbs per person, per day.

In extended sheltering situations, laundry services are made available to residents through onsite or offsite facilities.

Shelter facilities that are in compliance with Americans with Disabilities Act Accessibility Guidelines should be identified and used whenever feasible.

Accommodations for persons with disabilities, with health or mental health conditions, or who are elderly, are made whenever possible. Other resources might need to be identified to accommodate individuals who require additional assistance.

Availability of an alternative power supply is recommended.

Additional considerations of structural integrity, location, parking and back up energy supply should always be made when selecting a facility to be used as a disaster shelter.

Shelters are opened either pre-disaster or within two hours of notification or occurrence of a disaster event.

All shelter staff have received training and possess appropriate qualifications.

The ratio of staff to residents is appropriate to the size of the shelter. The minimum number of staff to open a shelter is four persons.

To meet the health needs, a shelter should be staffed with health professionals at a rate of one health and one mental health professional to 100 shelter residents. Adjustments may be made at night with consideration of the needs of the shelter population.

Signage is posted clearly throughout the facility indicating the rules of the shelter and assistance information such as essential phone numbers, location of exits, etc. Information should be posted in appropriate languages and accessible formats to ensure effective communication.

When a client enters a shelter, a process is used to determine if there are acute emergency medical needs or if special accommodations or referrals are required.

Shelter residents and staff are monitored for signs of illness and injury. Illnesses must be reported to the appropriate health professional in the shelter. If multiple shelter residents exhibit similar symptoms, local public health authorities shall be notified immediately.

Service animals are permitted in shelters.

The privacy of shelter residents is respected. Any personal information is kept secure and access is limited to those staff members who need information to provide service.

If children are present, a safe space for them to play and interact should be provided. This area should be staffed with trained, background checked personnel or children should be supervised directly by their parent or guardian

A hygienic environment is promoted throughout the shelter.

Waste receptacles are adequately spaced to allow for proper collection and emptied regularly to prevent overflow. Provide one 30 gallon container with lid and plastic bag for every 10 persons.

A contingency plan is established in the event of a loss of electrical power, loss of potable water or loss of plumbing.

Shelter kitchens follow local sanitation codes and personnel follow safe food handling procedures.



Snacks and beverages are available at shelters as soon as they are open or is practical and safe. A meal should be served within 4 hours or within the next traditional meal time (e.g. 6-8am; 11am-1pm, 5-7pm). A hot meal should be provided within 24 hours of opening.

Snacks are made available to shelter residents 24 hours per day.

Meals conform to cultural, ethnic, religious and dietary needs customary to the population being served within 36 hours provided the extent of the emergency allows.

A designated dining area is established. Food is not permitted outside this area.

Considerations as to the transition of shelter residents to more permanent housing are made at the onset of the sheltering operation.

Shelters have pre-established evacuation plans and shelter management is prepared to execute them if the need arises.

Advanced closing notification is required. In longer term shelters, it is appropriate to give notice at least 48 hours prior to closure. For those shelters that are open for a very short time period, less time is required. However, consideration of the shelter residents should be made in such cases.

### ***Feeding:***

All persons in want of food provisions are served without distinction of any kind.

Forecast the projected demand following the initial 24-48 hours.

Food distribution is responsive, transparent and equitable.

Provide meals in shelters as well as emergency community feeding through mobile distribution and / or fixed sites for affected individuals and families, emergency workers or other groups providing disaster relief. Provide meals to other agency shelters when the ability to do so exists.

Initiate mobile feeding, within six hours of safe access for staff, to affected individuals and families and relief workers returning to and cleaning up disaster-damaged homes. Provide meals in instances of severe disruption to electrical power and other utilities.

Establish fixed feeding sites when there is a high concentration of disaster affected individuals and families at specific locations. Such sites may include:

- Community or civic centers
- Search and rescue sites
- Emergency services command centers

- Apartment buildings
- Levee worker crew sites
- Site of a mass casualty incident
- At the kitchen site where food is prepared.

All staff have received requisite training, including safe food handling, and possess appropriate qualifications to deliver feeding services.

Food donated by individuals is not accepted. All in-kind donations of prepared (cooked) food must be from commercial vendors or recognized partner agencies, in appropriate sizes and quantities.

All kitchen units abide by local, state and federal sanitation codes.

All food preparation and service meet the guidelines of the local health department on safe food handling.

Adequate restrooms and hand washing stations are provided at feeding sites.

Food temperatures are kept within the appropriate range to preserve food quality. Store and maintain food outside the temperature danger zone (TDZ) of 41° F and 135° F. Prepared food held within the TDZ longer than 4 hours must be discarded. Ensure that hot foods stay hot (above 135° F) and cold foods stay cold (below 41° F).

All modes of transportation for mobile feeding units are equipped to maintain proper food temperatures and safe handling.

Consistent with individual needs and dietary recommendations, provide a daily diet of at least 2,000 calories with sufficient amounts of vitamins and nutrients (based on federal nutrition guidelines).<sup>1</sup>

Standard serving sizes for meals are 8 oz. entrees, 6 oz. side dishes and 6 oz. dessert, measured in volume.

To identify food waste use the difference between meals prepared and meals served. If the difference is greater than ten percent it is considered wasteful.

Ensure that meals served meet the cultural, ethnic, religious and dietary needs of the affected individuals within 36 hours in shelters and as soon as practical at other locations.

---

<sup>1</sup> USDA Dietary Guidance, [http://riley.nal.usda.gov/nal\\_display/index.php?info\\_center=4&tax\\_level=3&tax\\_subject=256&topic\\_id=1342&level3\\_id=5140&level4\\_id=0&level5\\_id=0&placement\\_default=0](http://riley.nal.usda.gov/nal_display/index.php?info_center=4&tax_level=3&tax_subject=256&topic_id=1342&level3_id=5140&level4_id=0&level5_id=0&placement_default=0)  
DRI: Recommended Intakes for Individuals, <http://www.iom.edu/Object.File/Master/21/372/0.pdf>

Advanced notice is given to the affected community prior to food delivery shutdown.

***Water:***

In the event that the normal supply of water is contaminated or interrupted, organizations may initiate distribution of bottled water, the quality of which meets all applicable health standards.

Water may be distributed at shelters, fixed distribution sites and/or by mobile distribution.

Potable water is supplied in a sufficient amount to meet the needs of the shelter operations. Consideration should be given to additional supply demands created by cleaning, food service operations, laundry, drinking, bathing, and other hygiene purposes.

Water quality must meet all applicable federal, state and local sanitation standards.

Bottled water is provided in sealed containers that meets federal, state and local sanitation standards.

Hauled or Bulk water is delivered in approved containers from a safe source that meets federal, state and local sanitation standards.

Water distribution is responsive, transparent and equitable and takes into consideration the dignity of the individual.

***Bulk Distribution:***

Bulk distribution items are determined by the disaster caused needs of the community, including the following:

- Type of damage
- What infrastructure is affected (are stores open, stocked with food, baby items, etc.)?
- Perimeter of the disaster affected area.
- Special needs of vulnerable populations.
- Approximate number of families affected.
- General extent of damage to homes.
- If the disaster event is over or continuing.
- Projected escalation of the event.
- Status of utilities.
- Access to disaster affected areas and populations.
- Road conditions.

- Services provided by other agencies.
- Percentage of population that will remain in or return to homes.
- Percentage of population that currently have access to homes for clean-up and salvage efforts and a timeline for remainder of population to gain access to their homes.
- Specific items needed.

Trigger points to initiate Bulk Distribution include:

- Specific community needs for products to assist in relief and/or recovery during or after a disaster are identified.
- Percentage of population isolated, making Bulk Distribution the most reasonable method of service delivery.
- Infrastructure of regular supply routes to local vendors severely hindered.
- Feeding requirements beyond Red Cross capacity and indications that this will continue.
- Extreme weather conditions that create an unusually high demand for items such as water, blankets and other essentials.

Distribution of items essential to basic survival, health and sanitation are prioritized before items for clean-up and recovery.

Several considerations are made in determining the amount, type and size of product selected for distribution, including:

- Immediacy of need
- Supply chain
- The number of times clients will need to return to obtain the supplies
- The number of different products offered at one time
- How much clients can be expected to carry
- The ratio of clients in vehicles versus on foot
- How much product is available to be issued
- How much is immediately available versus on order

Duplication of services is minimized.

Distribution is carried out in a timely manner.

Items are distributed equitably and are made accessible to all. This may necessitate mobile distribution and/or fixed sites. Examples of fixed sites include:

- Service delivery sites
- Service centers
- Community centers
- Churches
- Fire stations
- Government offices
- Respite centers

- Parking lots

Food items are stored off the ground and are protected from pests and the environment.

Advanced notice is given prior to distribution shutdown.

### ***On-Site Donations Management***

It is best to separate donation sites from bulk distribution sites for logistical reasons. However, there may be times when donation sites may be co-located with bulk distribution points. If this occurs, the two areas must be distinctly separated with different access.

Accepting donations of goods instead of buying products can be a useful way to save money on needed disaster supplies and to provide a positive experience for donors who can then feel that they are contributing to the relief effort. However, there are certain conditions donations must meet in order to be appropriate for relief efforts.

- Must meet an identified need
- Large, bulk donations of products to match specific quantities: To provide an equitable distribution of disaster supplies, attempt to only accept products donated in quantities large enough to support the needs of all or most of the affected population.
- Packaging: Whenever possible, product should be received on pallets and shrink-wrapped to facilitate sorting and ensure fast equitable distribution.
- Condition: Only accept products that are in good condition and that are not expired. Be careful about accepting used items because it is difficult to ensure their quality.
- Appropriateness: Do not accept products that are not familiar to the affected population, or products that are not appropriate due to cultural or religious considerations. Certain items can also be inappropriate for particular climates.

## **Standards and Indicators for Disaster Shelter Care for Children**

### **Purpose**

To provide guidance to shelter managers and staff that ensures children have a safe, secure environment during and after a disaster – including appropriate support and access to essential resources.

### **Standards and Indicators for All Shelters**

Under most circumstances a parent, guardian or caregiver is expected to be the primary resource for their children, age 18 and younger.

In cases where parents or guardians are not with their children, local law enforcement personnel must be contacted to assist with reunification. In many cases, local law enforcement will also contact local child protective/child welfare services for their expertise.

Children are sheltered together with their families or caregivers.

Every effort is made to designate an area for families away from the general shelter population.

Family areas should have direct access to bathrooms.

Parents, guardians, and caregivers are notified that they are expected to accompany their children when they use the bathrooms.

Every effort is made to set aside space for family interaction:

This space is free from outside news sources thereby reducing a child's repeated exposure to coverage of the disaster.

If age-appropriate toys are available they will be in this space, with play supervised by parents, guardians or caregivers.

Shared environmental surfaces in shelters that are frequently touched by children's hands or other body parts should be cleaned and disinfected on a regular basis. High contact areas may include diaper changing surfaces, communal toys, sinks, toilets, doorknobs and floors. These surfaces should be cleaned daily with a 1:10 bleach solution or a commercial equivalent disinfectant based on the manufacturer's cleaning instructions. Local health department authorities may be consulted for further infection control guidance.

When children exhibit signs of illness, staff will refer children to on-site or local health services personnel for evaluation and will obtain consent from a parent, guardian or caretaker whenever possible.

When children exhibit signs of emotional stress, staff will refer children to on-site or local disaster mental health personnel and will obtain consent from a parent, guardian or caretaker whenever possible.

Children in the shelters come in all ages and with unique needs. Age appropriate and nutritious food (including baby formula and baby food) and snacks are available, as soon as possible after needs are identified.

Diapers are available for infants and children as soon as possible after needs are identified. General guidelines suggest that infants and toddlers need up to 12 diapers a day.

Blankets, for all appropriate ages, are also available.

A safe space for breastfeeding women is provided so they may have privacy and a sense of security and support (this can include a curtained off area or providing blankets for privacy).

Basins and supplies for bathing infants are provided as soon as possible after needs are identified.

## **Standards and Indicators for Temporary Respite Care for Children**

Temporary Respite Care for Children provides temporary relief for children, parents, guardians or caregivers. It is a secure, supervised and supportive play experience for children in a Disaster Recovery Center, assistance center, shelter or other service delivery site. When placing their child or children in this area, parents, guardians or caregivers are required to stay on-site in the disaster recovery center, assistance center or shelter or designate a person to be responsible for their child or children, who shall also be required to stay on-site.

In cases where temporary respite care for children is provided in a Disaster Recovery Center, assistance center, shelter and other service delivery site, the following Standards and Indicators shall apply:

Temporary respite care for children is provided in a safe, secure environment following a disaster.

Temporary respite care for children is responsive and equitable. Location, hours of operation and other information about temporary respite care for children is provided and easy for parents, guardians and caregivers to understand.

All local, state and federal laws, regulations and codes that relate to temporary respite care for children are followed.

The temporary respite care for children area is free from significant physical hazards and/or architectural barriers and remains fully accessible to all children.

The temporary respite care for children area has enclosures or dividers to protect children and ensure that children are supervised in a secure environment.

The temporary respite care for children area is placed close to restrooms and a drinking water source; hand washing and or hand sanitizer stations are available in the temporary respite care for children area.

Procedures are in place to sign children in and out of the temporary respite care for children area and to ensure children are only released to the parent(s), guardian(s), caregiver(s) or designee(s) listed on the registration form.

All documents---such as attendance records and registration forms (which include identifying information, parent, guardian or caregiver names and contact information), information about allergies and other special needs, injury and/or incident report forms---are provided, maintained, and available to staff at all times.

Toys and materials in the temporary respite area are safe and age appropriate.

Prior to working in the temporary respite care for children area, all shelter staff members must receive training and orientation. In addition, such staff must successfully complete a criminal and sexual offender background check. Spontaneous volunteers are not permitted. When inside the temporary respite area, staff shall visibly display proper credentials above the waist at all times.

When children are present, at least two adults are to be present at all times. No child should be left alone with one adult who is not their parent, guardian or caregiver.

All staff members must be 18 years or older. Supervision of the temporary respite care for children area is provided by a staff person at least 21 years of age.

An evacuation plan will be developed with a designated meeting place outside the center. The evacuation plan will be posted and communicated to parent(s), caregiver(s), and guardian(s) when registering their child.

The child to staff ratio is appropriate to the space available and to the ages and needs of the children in the temporary respite care for children area at any time.



## **Appendix G:**

Guidance for Implementation of  
Public Shelter Design Criteria

## **Appendix G –Guidance for Implementation of Public Shelter Design Criteria**

### **G.0 PUBLIC SHELTER DESIGN CRITERIA**

The public shelter design criteria, which are also known as the EHPA criteria, were developed to ensure that appropriate new educational facilities can serve as public hurricane evacuation shelters. The EHPA criteria provide supplemental code provisions to existing applicable codes and standards. The EHPA criteria are performance-based, with limited prescriptive options provided to serve as a guide toward achieving the required level of performance.

The SREF public shelter design criteria are promulgated in section 423.25, *Florida Building Code—Building* (FBC). This section of the code applies to public schools (K-12) and community colleges. The Division also recommends use of the EHPA criteria for new state university, and other state, local and privately-owned facilities that are suitable to serve as public hurricane evacuation shelters.

The EHPA criteria were also prepared to ensure that new educational facilities could meet or exceed applicable national design and construction standards, guidelines and “best practices.” In particular, the American Red Cross’ ARC 4496 should be consulted during the planning and design process for an EHPA; see Appendix C. ARC 4496 is the minimum hurricane shelter criteria used by the Division, American Red Cross and local emergency management officials for surveying, ranking and designating public hurricane evacuation shelters.

ARC 4496 can also be viewed at the following web address:

<http://www.floridadisaster.org/Response/engineers/documents/newarc4496.pdf>

Limited guidance is also provided to assist with design of EHPA’s when pre-designated as Special Needs Shelters (SpNS). There currently aren’t any consensus codes and standards published specifically for SpNSs. However, the guidance included in this Plan is consistent with policies and recommendations distributed by the Department of Health.

### **G.1 EHPA Occupancy Period**

For planning purposes, the EHPA is assumed to be occupied at its maximum occupant capacity for, at a minimum, a continuous eight (8) hour period of exposure to major hurricane conditions (i.e., Category 3 or higher). Off-site and unprotected on-site structures and utilities should be assumed to be inoperable, damaged or destroyed.

Though the EHPA criteria assume an 8-hour design occupancy period, hurricane evacuation shelters may be occupied for about 24 to 36 hours in advance of arrival of hurricane force winds, 8 to 24 hours during hurricane conditions, and 24 to 72 hours (or longer) after hurricane force winds subside. Boards, design professionals and emergency

managers should consider this fact during the design of an EHPA. A design planning guide of 24 hours of self-sufficient operations at maximum occupant capacity may be more appropriate. A design occupancy minimum duration of 24 hours is also consistent with the International Code Council's *Standard on the Design and Construction of Storm Shelters* (ICC 500).

## **G.2 Structural Requirements**

The wind load performance objective of modern building codes and standards is to prevent or reduce deaths and injuries within the built environment. This is achieved through design and construction of buildings such that, under design loads, primary load carrying systems remain stable and do not collapse. Survival without collapse implies that occupants should be able to find an area of relative safety inside the structure during a severe wind event. Localized damage, breach of the structural envelope and flow of wind through the structure and water damage are acceptable. However, this design philosophy is not necessarily acceptable for public hurricane evacuation shelters (and certain other essential facilities).

Hurricane Andrew (1992) and other subsequent major hurricanes demonstrated that the potential exists for hundreds of shelter occupants to find themselves scrambling for safety as the structural envelope of a designated public shelter progressively disintegrates. This scenario is unacceptable to emergency management and other public officials. The EHPA criteria were developed to significantly enhance the safety of public hurricane evacuation shelters, and enhance their ability to survive and continue to serve the public after exposure to a major hurricane. Therefore, the performance expectation for EHPA's is that not only the structural frame resist collapse in a Category 3 or greater hurricane, but that the exterior envelope components, cladding materials and assemblies must also remain sufficiently intact to protect building occupants and preserve the mass care function.

**G.2.1 Wind Loads.** EHPA's are required to be designed and constructed in accordance with the wind load provisions of the American Society of Civil Engineers Standard 7, *Minimum Design Loads for Buildings and Other Structures* (ASCE 7). The minimum design wind speed is per ASCE 7's Risk Category IV (essential facility). Also, to ensure that the EHPA remains an enclosed structure (and avoid a partially enclosed condition, which would invalidate the design), building openings are also required to withstand impact by large windborne debris in accordance with ASTM E-1886 and ASTM E-1996 or SSTD 12.

The selection of an appropriate design wind speed is critical to the performance of public hurricane evacuation shelters. ASCE 7-2010's design wind speed maps are based upon approximately a 700-year recurrence for Risk Category II (ordinary risk), and a 1,700-year recurrence for Risk Categories III (substantial risk) and IV (essential facilities). The ASCE 7-2010 and 2010 FBC—Building design wind speed map for Risk Categories II can be seen on Figure G-1 and Risk Categories III and IV can be seen on Figure G-2. The increase in recurrence interval for Risk Categories III and IV accounts

for a greater degree of hazard to human life or the community due to the nature of a facility's occupancy or use. Risk Category IV is the minimum wind design and construction requirement for EHPA's, and reflects the **minimum** state and national design standard.

However, the EHPA code provisions highly recommend that the ASCE 7 map wind speed be increased by 40 miles per hour. The Division also highly recommends the 40 mile per hour increase in base wind speed. The 40 mile per hour increase translates into wind designs of as high as 220 miles per hour in south Florida and 240 mph in the Florida Keys, to as low as 165 miles per hour in inland north-central Florida. The increase in design wind speed improves consistency of the EHPA wind load design provisions with those of the Department of Energy's (DOE) high wind design criteria, the national storm shelter standard ICC 500's hurricane provisions and the Federal Emergency Management Agency's (FEMA) publication *Design and Construction Guidance for Community Safe Rooms* (FEMA 361).

FEMA 361 can be viewed at the following web address:

<http://www.fema.gov/library/viewRecord.do?id=1657>

The Department of Energy's enhanced performance expectations are that its facilities not only resist collapse, but that occupants, critical equipment and contents be protected from wind, windborne and falling debris, rainwater intrusion, and continue to maintain operation as an essential facility. The Department of Energy's enhanced performance expectations are more consistent with public hurricane evacuation shelter design and construction performance expectations than ASCE 7's minimum design standard.

DOE-STD-1020-2002 can be viewed at the following web address:

<http://www.floridadisaster.org/Response/engineers/documents/STD-10202002.pdf>

The Division also recommends use of exposure C (open unsheltered terrain) when calculating design wind load, regardless of the design wind speed selected or the environmental conditions surrounding the proposed facility. Both ASCE 7 and the FBC permit use of exposure B (sheltered terrain) in areas more than a mile from the coast, which can significantly reduce the needed design capacity of a facility. Severe hurricanes, like Hurricane Andrew, tend to scour the environment by blowing over trees and flattening lightweight or poorly constructed structures. This scouring reduces the sheltering effect of a facility's normal environment. Severe hurricanes can also produce "micro-burst" and weak to moderate tornado-type damage, which can devastate a small area and negate the influence of any local environmental sheltering. Therefore, for consistency with ICC 500 and FEMA 361, the Division recommends use of exposure C when calculating design wind load.

The EHPA code recommended 40 mile per hour increase in design wind speed doesn't achieve a near-ultimate (or "near-absolute") level of protection for building

occupants. However, it does provide an “enhanced” (or intermediate) level of protection between minimum ASCE 7 design requirements and near-ultimate levels of protection. ICC 500, DOE-STD-1020 (Performance Category-4) and FEMA 361 are intended to provide near-ultimate protection for shelter occupants. They base their respective hurricane wind designs on 10,000-year recurrence interval events; i.e., a one (1) percent or less chance of occurrence during the life of a structure. Figure G-3 shows the design wind speed map for the hurricane provisions of ICC 500 and FEMA 361. Figure G-4 illustrates a 10,000-year recurrence interval wind speed map for Florida.

The EHPA criteria also require that roof assemblies remain waterproof (i.e., rain tight) to preserve the emergency management function. Therefore, roof weather membranes (or secondary rain barriers) must meet the wind load requirements.

The Division also strongly recommends the addition of 40 miles-per-hour to the Risk Category IV map wind speed due to reductions in design wind loads between the predecessor ASCE 7-2002 and 2004 FBC—Building EHPA design procedures and their respective 2010 design procedures. Based on a review of design wind loads at representative locations across the state, ASCE 7-2002 and 2004 FBC—Building minimum EHPA averaged about 70 percent less than ICC 500 design wind loads. However, the addition of 40 mph to the map wind speed (Importance Factor I=1.00) provided an average of about 16 percent higher design wind loads than ICC 500. ASCE 7-2010 and 2010 FBC—Building minimum EHPA (Risk Category IV) averaged about 130 percent less than ICC 500 design wind loads, and the EHPA (Risk Category IV) recommended addition of 40 miles per hour averaged 44 percent less than ICC 500 design wind loads.

Table G-1 provides a comparison of key design factors that influenced the results of the design wind load review. The single biggest change was reduction of ASCE 7 and FBC’s wind load combination factor from 1.6 to 1.0. All other design criteria being equal, the increase in design wind speeds given in the 2010 basic wind speed maps was insufficient to offset this reduction.

<b>Table G-1 Wind Design Factor Comparisons for ICC 500, 2004 EHPA and 2010 EHPA</b>					
<b>Design Criteria</b>	<b>ICC 500</b>	<b>2004 FBC EHPA, minimum</b>	<b>2004 FBC EHPA, map+40 mph</b>	<b>2010 FBC EHPA, minimum*</b>	<b>2010 FBC EHPA, map*+40 mph</b>
Design Wind Speed Map	ICC 500 (160-225 mph)	ASCE 7 (100-150 mph)	ASCE 7 (140-190 mph)	ASCE 7 (125-200 mph)	ASCE 7 (165-240 mph)
Map Wind Speed Increase, mph	N/A	0	40	0	40
Importance Factor, I	1.00	1.15	1.00	N/A	N/A
Directionality Factor, <i>K<sub>d</sub></i>	1.00	0.85	0.85	0.85	0.85
Exposure Category	C	C	C	C	C
Internal Pressure Coefficient, <i>GC<sub>pi</sub></i>	+/- 0.55	+/- 0.18	+/- 0.18	+/- 0.18	+/- 0.18
Wind Load Combination Factor	1.00	1.60	1.60	1.00	1.00
* – Risk Category IV; N/A – Not Applicable					

Though the increase in map wind speeds appear to reduce the gap in hurricane wind design criteria between ASCE 7 and EHPA with that of ICC 500, the results do not support the improvement. To maintain the EHPA’s performance expectations as an

enhanced” or intermediate level of protection, the Division strongly recommends the addition of 40 mph to the Risk Category IV map wind speed.

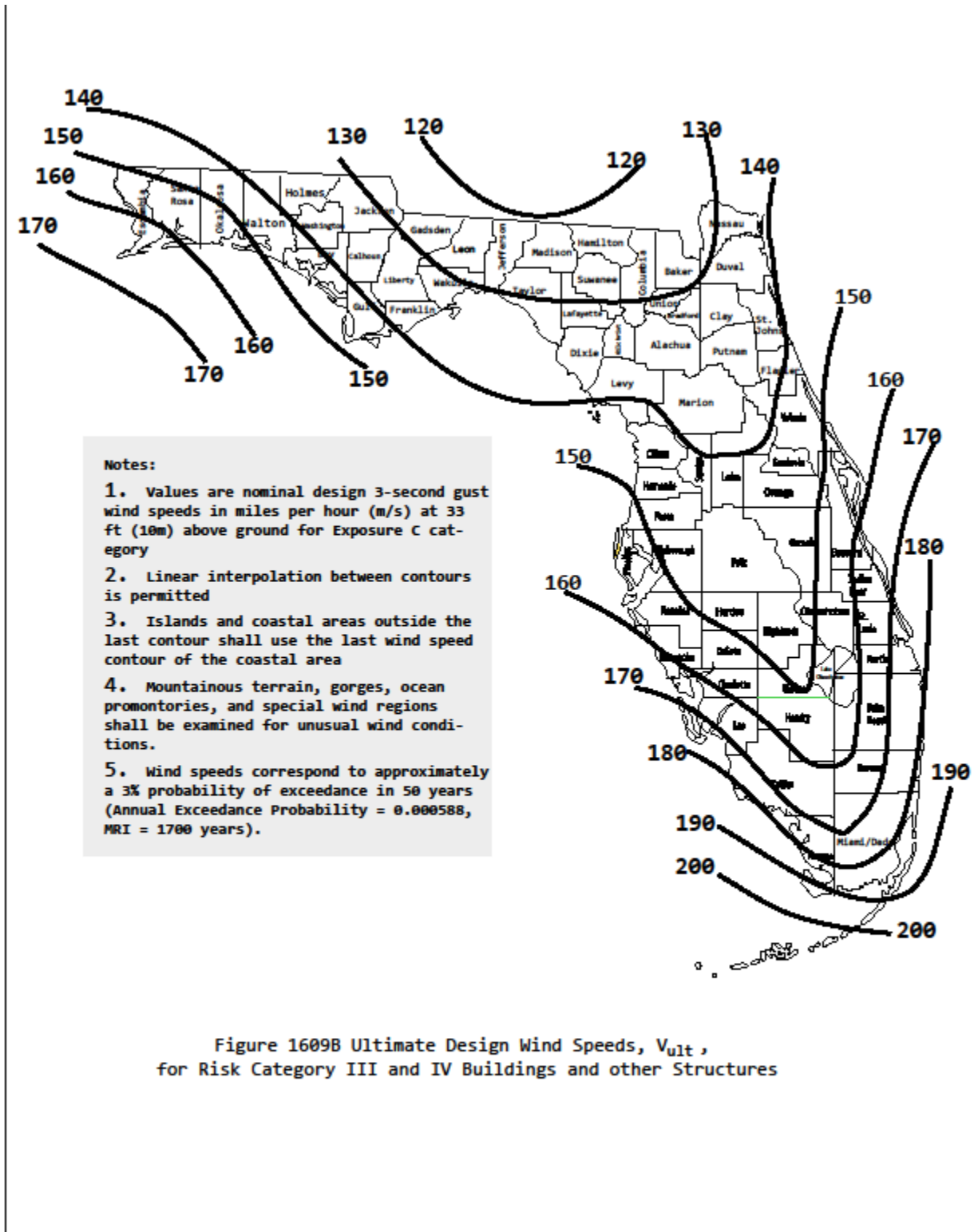
Another consideration when selecting a design wind speed is differences between ASCE 7 and hurricane intensity wind speed measurements. ASCE 7’s basic wind speed map uses a 3-second gust wind measurement method. However, the National Hurricane Center (NHC) and National Weather Service (NWS) categorize hurricanes using the Saffir-Simpson Hurricane Intensity Scale, which uses a one-minute sustained wind measurement method. Table G-2 provides a comparison of common wind measurement methods. For comparison purposes, visualize an anemometer (measures wind velocity) with Table G-2 representing concurrent scales on its wind speed display, similar to a vehicle speedometer that registers vehicle speed in both miles per hour and kilometers per hour. The anemometer will read about 135 miles per hour on the 3-second gust scale when the 1-minute sustained scale reads 111 miles per hour.

<b>TABLE G-2. Equivalent Basic Wind Speeds</b>						
Wind Speed Conversion						
3-second gust, fastest-mile and 1-minute sustained velocities (mph)						
<b>Wind Measurement Method</b>	<b>Saffir-Simpson Hurricane Intensity Scale</b>					
	<b>Category 1</b>	<b>Category 2</b>	<b>Category 3</b>	<b>Category 4</b>	<b>Category 5</b>	<b>Extreme Category 5</b>
<b>3-second Gust</b> (ASCE 7 and 2004 Florida Building Code)	90	117	135	160	190	230
<b>Fastest-Mile</b> (Standard Building Code)	75	100	117	141	170	209
<b>1-minute Sustained</b> (National Hurricane Center)	74	96	111	131	156	188

The NHC defines a major hurricane as one that achieves Category 3 or higher intensity on the Saffir-Simpson Scale. National guidance also indicates that all of Florida is subject to exposure to major hurricane conditions, with some locations in South Florida and the panhandle regions especially susceptible to severe hurricanes. Therefore, to ensure that public hurricane evacuation shelters are designed and constructed to resist major hurricanes, the 40 mile per hour increase in base wind speed is critical to achieve the EHPA performance expectation.

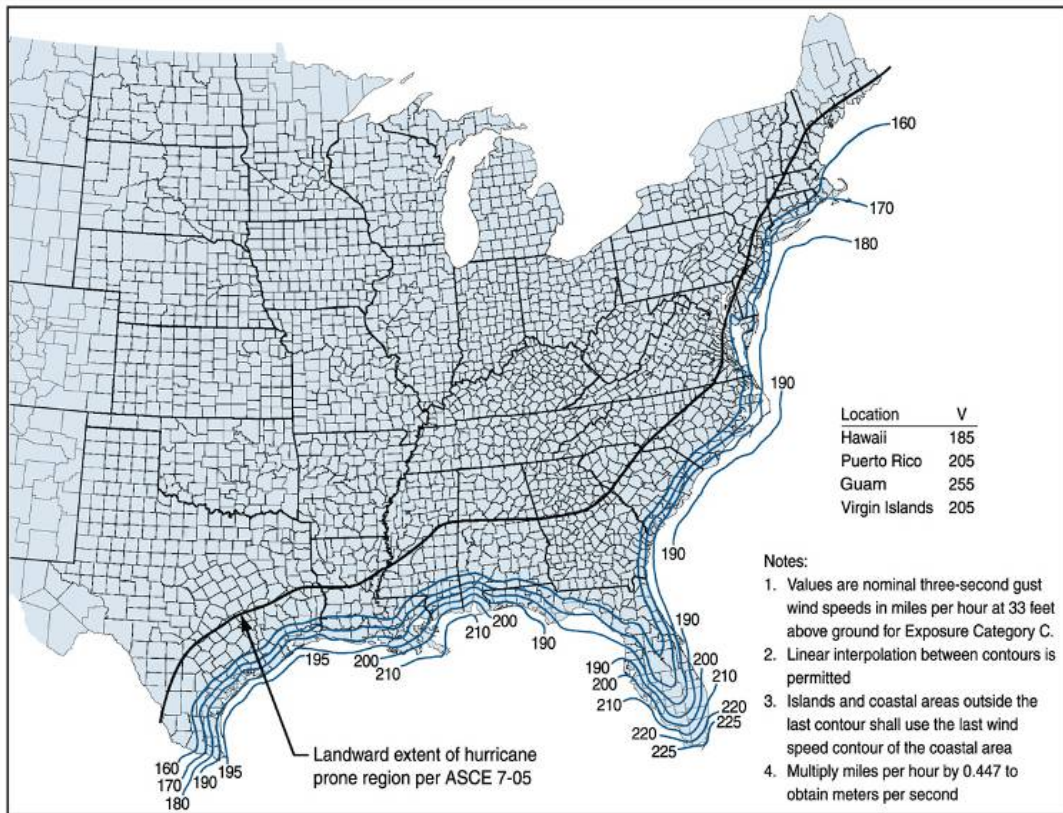


**Figure G-2. ASCE 7-2010 and 2010 Florida Building Code—Building, Risk Category IV Design Wind Speed Map**



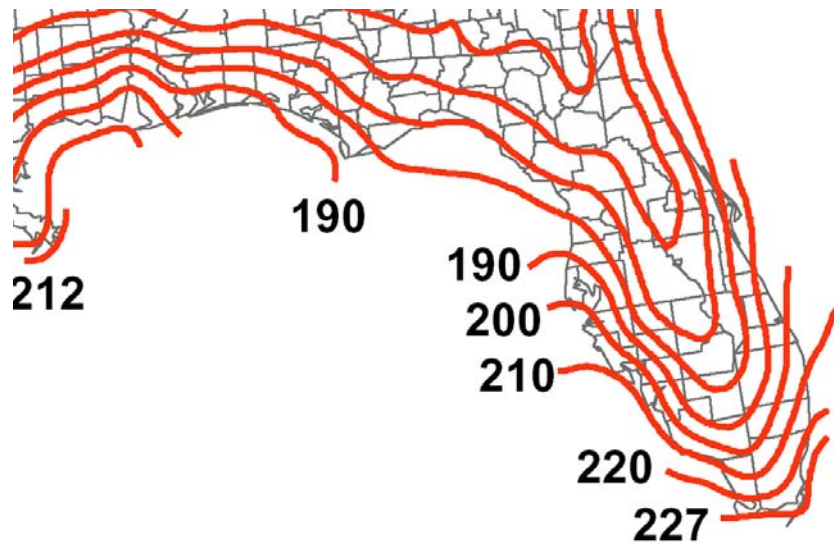


**Figure G-3. ICC 500 Hurricane Design Wind Speed Map**  
**Source: International Code Council**



SOURCE: ICC/INSSA STANDARD FOR THE DESIGN AND CONSTRUCTION OF STORM SHELTERS (ICC-500). COPYRIGHT 2008, WASHINGTON, DC: INTERNATIONAL CODE COUNCIL. REPRODUCED WITH PERMISSION. ALL RIGHTS RESERVED. WWW.ICCSAFE.ORG < HTTP://WWW.ICCSAFE.ORG >.

**Figure G-4. 10,000-year High Wind Recurrence Map for Florida**  
**Source: International Code Council**



**G.2.2 Windborne Debris Impact.** All exterior surface components and cladding materials of EHPA's, and their supporting assemblies, are required to resist windborne debris impact. This includes walls, roofs, windows, skylights, glass block, doors, louvers, etc. This requirement is applicable to all EHPA's, regardless of proposed siting in a location outside of the normal windborne debris regions prescribed in ASCE 7 or the FBC. The minimum debris impact standards are ASTM E 1886 and ASTM E 1996 or SSTD 12. That is, the pertinent cladding materials and assemblies must, at a minimum, resist penetration by a nominal 2"x4" lumber plank weighing nine (9) pounds propelled at 34 miles per hour (50 feet per second) and striking "end-on" and perpendicular to the assembly. Though not specifically cited in section 423.25.4.1, FBC, windborne debris impact resistant assemblies meeting the requirements of section 1609.1.4, FBC (including Miami-Dade TAS 201, 202 and 203) are recognized by the Division as suitable minimum alternatives. Construction assemblies that are "deemed to comply" with section 1626, FBC--Building, are also considered suitable. For guidance on additional types of assemblies that have been tested and passed large missile performance criteria, please see Appendix K.

However, please note that the Department of Education has stated that roof assemblies must be tested and certified to meet ASTM E 1886 and ASTM E 1996 or SSTD 12 as an assembly. This applies to district school board and community college facilities. With the exception of code prescribed concrete deck assemblies, "deemed to comply" assemblies will not be approved by the Department of Education. Therefore, "deemed to comply" assemblies are only applicable to other state and local agency facilities.

The Florida Department of Education's list of approved roof decks can be found at the following web address:

<http://www.fldoe.org/edfacil/formsplanreview.asp>

The Division recommends that facilities that may be subjected to an unusual barrage of heavy debris and building wreckage incorporate a more rigorous debris impact standard. This includes facilities that are located within 300 feet of significant exposure to unanchored large object debris sources or poorly constructed/partially engineered buildings. An example is an EHPA facility proposed to be located adjacent to a partially engineered unreinforced masonry building; portions of roof and wall materials, roof top equipment and building contents may be entrained into the wind field as the weak building disintegrates under severe wind loads. This heavy debris can have devastating impacts upon inadequate roof and wall components, cladding materials and assemblies, and potentially create significant breaches in the shelter building's structural envelope. Also, intrusion of heavy debris through the shelter building's envelope can present a hazard to building occupants.

For unusual windborne debris hazard exposure, the Division, at a minimum, recommends the hurricane wind hazard debris impact resistance criteria published in ICC 500 or DOE-STD-1020, or similar performance standards. DOE-STD-1020 requires that

the facility's exterior envelope components, cladding materials and assemblies resist penetration by a nominal 2"x4" sawn lumber plank weighing 15 pounds propelled at 50 miles per hour (73.4 feet per second) and striking "end-on" and perpendicular to the assembly. ICC 500 provides a similar performance alternative of a nine (9) pound 2"x4" propelled at about 90 miles per hour (132.0 feet per second). This is about a 165 percent increase in impact momentum over SSTD 12's basic large missile impact standard. There are products on the market that have been (or could be) certified to this level of performance, and DOE-STD-1020 provides "deemed to comply" type guidance for roof and wall assemblies. FEMA 361 also provides debris impact design criteria for facilities located in areas potentially exposed to extreme intensity wind events and debris impact loadings.

The design professionals-of-record should consider the fact that occupants of EHPA's may open doors and windows during hurricane conditions. This human behavior was often reported during the 2004 hurricane season; see section G.2.5 for additional information. The basic design criteria for essential facilities, including EHPA's, assumes a substantially enclosed structure with controlled air movement and pressure changes (positive and negative). Though it is not known if occupants would purposely open fenestrations during a near design-level-event, designers should consider the effect that opening of the largest operable door or window would have on an EHPA's enclosure classification. If the enclosure classification changes due to the opening, the designer should consider possible mitigation measures (e.g., partially enclosed design classification, construction of air-trap/air-lock vestibules, access-limiting measures, etc.)

**G.2.3 Foundations and Floor Slabs.** The finished floor elevation of EHPA's and their essential life safety and emergency support systems are required to be elevated above the maximum storm surge inundation elevation associated with a Category 4 hurricane event. In multistory or elevated buildings, this applies to the lowest EHPA floor. The storm surge elevations are identified by reviewing the most current Sea, Lake and Overland Surges from Hurricanes (SLOSH) studies and atlases.

Some computer-based SLOSH models are also available, such as SLOSH Display Program version 1.63. These models list several elevations based upon "hurricane scenario," which includes storm intensity, forward speed and track. It is not uncommon for a site located in a Category 4 or 5 storm surge zone to be listed as "dry" for all but a few scenarios, and could possibly be dry for all scenarios due to elevation of local grade. The EHPA design requirement is the highest elevation listed for a Category 4 hurricane event.

The Division's minimum recommendation for rainfall flood design elevation for EHPA's is ASCE *Flood Resistant Design and Construction* (ASCE 24) Classification Category IV, Essential Facility. That is, the minimum elevation must be at least two (2) feet above base flood elevation (BFE) or a community's Design Flood Elevation, whichever is greater. However, where determined, the lowest habitable EHPA floor elevation should be at or above the 500-year flood elevation.

**G.2.4 Certifications.** Board and emergency management agencies have often found that it is difficult, if not impossible, to document that a facility was designed and constructed to the EHPA criteria after the passage of time. Construction drawing notes often do not provide the required information, and building officials, design professionals-of-record, constructors, product manufacturers and providers, and other relevant agents move on to other projects. Maintaining a viable record to certify that a facility has been designed and constructed to meet the EHPA criteria is critical.

The following information is needed by emergency managers to document that a facility is an EHPA:

1. Statement that the wind design conforms to the provisions of the Public Shelter Design Criteria, Section 423.25, Florida Building Code with year of revision specified
2. Statement that the building or EHPA, as applicable, is capable of withstanding or exceeding wind loads according to ASCE 7 structural design criteria (this statement is essential for ARC planners)
3. Basic Wind Speed, mph
4. Wind Importance Factor ( $I$ ); if applicable by standard or code in effect
5. Wind Exposure
6. Wind Directionality Factor ( $K_d$ )
7. Internal Pressure Coefficient ( $GC_{pi}$ )
8. Provide documentation that walls, windows, doors, louvers, roofs, skylights, exhaust fans, rooftop air-conditioning equipment and other exterior components comply with ASTM E 1886 and E 1996, SSTD 12 or other applicable performance standards (e.g., FBC High Velocity Hurricane Zone testing protocols TAS 201, 202 and 203, etc.); documentation may include large missile impact product approval notice(s), certified lab test results, etc.
9. Floor plan drawing or image indicating location of EHPA portions of the facility; includes drawing or image indicating the entire facility when applicable

The documentation can be provided in the form of a certification statement letter or memorandum, or as a note page within the construction drawings of record. It is requested that the design professionals-of-record sign and seal the certification document(s), and forward the certification to the board, local emergency management agency and Division.

**G.2.5 Observations from the 2004 and 2005 Hurricane Seasons.** Following the 2004 and 2005 hurricane seasons, federal, state and local building code and mitigation assessment teams observed the types of damages found in the most heavily impacted areas of Florida. In general, the impacted EHPA's performed in a manner similar to other recently constructed light commercial facilities. That is, there were no observed structural failures but improvements were recommended for cladding integrity and weather protection. In particular, roof coverings, light metal exterior wall coverings, soffits and door hardware damage led to rainwater intrusion.

The following is a summary of selected recommendations from the federal Mitigation Assessment Team for critical/essential facilities (which includes shelters):

1. To better ensure adequate performance of shelters, the 40 mile per hour increase in base wind speed should be required and not just “highly recommended.”
2. Ensure that appropriate ASCE 7 Exposure Categories are selected during the design process; ensure full wind loads are calculated in open areas (Exposure C) where reductions are not appropriate.
3. The minimum windborne debris impact criteria should be increased from the current SSTD 12/ASTM E 1996 Level D (9 lb 2”x4” @ 34 mph) basic protection to the essential facility Level E (9 lb 2”x4” @ 55 mph) enhanced protection.
4. Assure code compliance through increased enforcement of construction inspection requirements, such as the Threshold Inspection Law.
5. It was recommended that designers calculate loads on building envelope cladding and components (including soffits), roof coverings and roof top equipment and specify/detail adequate attachments to resist the loads. A minimum safety factor of 2.0 is typically recommended. Note that industry or manufacturers’ recommendations may be higher than 2.0.
6. For roof coverings, a secondary weather-resistant underlayment is recommended to improve rainwater intrusion protection.
7. Designers should clearly indicate on the construction drawings the area of the facility that was designed to function as the high wind shelter or hardened core area.
8. Perform follow-up inspections every five years or after a hurricane to identify interior moisture damage that may affect the structure or building envelope.
9. It was recommended that designers consider and use guidance found in FEMA 361 and *Design Guide for Improving School Safety in Earthquakes, Floods and High Winds* (FEMA 424).

To view the full Hurricane Charley and Hurricane Ivan Mitigation Assessment Team Reports, please see FEMA 488 and 489 at the following web addresses:

[http://www.fema.gov/rebuild/mat/mat\\_fema488.shtm](http://www.fema.gov/rebuild/mat/mat_fema488.shtm)

[http://www.fema.gov/rebuild/mat/mat\\_fema489.shtm](http://www.fema.gov/rebuild/mat/mat_fema489.shtm)

Also, FEMA 424 can be viewed at the following web address:

<http://www.fema.gov/library/viewRecord.do?id=1986>

There was one finding during the 2004 hurricane season that is related to human behavior that could increase the vulnerability of shelters. About forty (40) percent of the sites reported that persons (evacuees, shelter staff and managers, and public safety officials) purposely opened windows and doors during hurricane conditions. The reasons

for the openings varied from admittance of late arrivals, to smoking, distribution of food and other supplies, fresh air ventilation, and equipment repairs or maintenance. Buildings are designed to be enclosed structures, and openings of possibly as small as one (1) percent of a building's exterior envelope can cause internal pressures that exceed original design loads. This essentially negates the benefits of any added window protection.

In less intense storms, such as the conditions experienced by most of the shelters in 2004, the effects caused by the openings were minimal, with occupants experiencing only minor atmospheric pressure changes and a temporary, but exaggerated, creaking of lightweight roof decks (e.g., metal). However, when doors were opened on building sides perpendicular to or opposite the windward facing walls, the doors occasionally were pulled open violently by suction forces. This may have damaged some doors making them impossible to re-close, and in one case may have broken a door window pane. For additional findings specific to occupied hurricane evacuation shelters during the 2004 season, please see Chapter 5, Performance of Public Shelters during the 2004 Hurricane Season, of the *2005 Shelter Retrofit Report*. The *2005 Shelter Retrofit Report* can be viewed at the following web address:

<http://floridadisaster.org/documents/SRR05.pdf>

**G.2.6 Roof and Utility Enclosure Rainfall Drainage.** The EHPA criteria requires that roof drain systems be sized for normal use (i.e., 100-year, 1-hour rainfall design per FBC—Plumbing, Figure 1106.1), and when applicable also required to have additional emergency overflow capacity. The Division recommends that where drainage confining roof perimeter construction or parapet are present, that at a minimum the secondary (emergency) roof drains or scuppers be designed for a minimum of an eight (8) inch, 1-hour rainfall rate. This is approximately a 2,000-year, 1-hour recurrence rainfall rate for Florida, so a low probability event. A rainfall design rate of 8 inches per hour is also consistent with ICC 500 standards.

The Division also recommends that utility, mechanical, electric and plumbing equipment enclosures with open or screen roofs provide similar emergency rainfall drainage capacity at or near floor or ground level.

### **G.3 Location and Site Requirements**

**G.3.1 Emergency Access.** EHPA's are required to have at least one major means of access for emergency vehicles that is above the 100-year floodplain. However, this requirement may be impractical in some areas due to generally low-lying topography. Therefore, this requirement can be waived by the board with concurrence of the local emergency management agency or the Division. A potential EHPA with access routes below the 100-year floodplain may be subject to isolation due to hurricane rainfall flooding, and should be reviewed as a potential exemption request per section 2.2.1 of this Plan.

**G.3.2 Landscaping and Parking.** Landscaping around the EHPA must be designed to preserve safety and emergency access. Trees must not conflict with overhead or underground utilities, including electricity, telecommunications, potable and wastewater, natural gas, etc. Trees, utility poles or other tall structures are required to be located to avoid lay-down or impact hazard for the EHPA and its occupants. The Division recommends that trees located within 50 feet of an EHPA be limited to trunk diameters that do not exceed about six (6) inches at maturity. This recommended standoff distance will prevent medium-size trees from inflicting battering damage to EHPA roofs, walls, windows and doors and reduce the potential for entry and egress door blockage.

Trees that exceed 12 inch trunk diameters may cause most of the lay-down impact damage to buildings. Therefore, the Division recommends that trees that typically exceed 12 inches in diameter at maturity should be located with a standoff distance of more than 100 feet from their base to the closest potential impact point of an EHPA's outside perimeter wall; preferably a standoff distance of more than 115 feet. However, due to their relatively greater height potential, pine trees (e.g., Slash, Spruce, Shortleaf, Longleaf, Loblolly, etc.) should be located with a standoff distance of more than 125 feet from the EHPA; preferably a standoff distance of more than 140 feet.

Tall tree species in Florida typically have trunk diameters at breast height (about four-and-a-half feet above the ground) of 12 to 36 inches and trunk heights of about 60 to 140 feet. Some species with continued growth may significantly exceed a trunk diameter of 36 inches, but seldom exceed heights of 140 feet. For planning purposes, with the exception of pine trees, the ratio of maximum expected (mature) tree diameter in inches to the total tree height in feet is about 1:3.5 (+/- 15%). As an example, for planning purposes, trees that can grow to a trunk diameter of 24 inches will reach a height of about 84 feet (+/- 13 feet). Pine trees have a greater height to diameter ratio than other tree species, which is closer to 1:4 (+/- 15%). These planning guides are useful for most tall trees (e.g., pine, oak, hickory, magnolia, maple, pecan, sycamore, etc.) that may pose a lay-down hazard to an EHPA during its expected life.

Structures, equipment and other objects within 300 feet of the EHPA's perimeter should be anchored to avoid generating large windborne, falling or roll-over debris. Vehicles must be parked more than 50 feet from the perimeter of the EHPA during hurricane conditions.

**G.3.3 Rainfall Drainage.** The civil designer may also want to consider the potential for exceptionally high rainfall rates that will exceed normal site drainage design standards. The following are select maximum single-day (24 hour) rainfall records for locations in Florida:

- Pensacola – 11.68 inches
- Crestview – 11.44 inches
- Apalachicola – 10.67 inches
- Tallahassee – 8.86 inches
- Jacksonville – 6.33 inches
- Yankeetown – 38.7 inches (Florida Record)
- St. Petersburg – 15.45 inches
- Tampa – 11.45 inches

Orlando – 8.19 inches  
Melbourne – 27.65 inches  
Fort Myers – 9.92 inches  
West Palm Beach – 15.22 inches  
Miami – 12.56 inches  
Key West – 22.75 inches

Other extreme rainfall events of note for the United States:

Alvin, TX (1979) – 43 inches (NWS national record)  
Dauphin Island, AL (1997) – 32.5 inches  
Hackberry, LA (1962) – 22.0 inches  
Americus, GA (1994) – 21.1 inches

During slow-moving large “wet” hurricanes, a 10 to 20 inch or greater rainfall event is quite possible. The designer should consider the impact that flooded parking lots, overwhelmed storm drains and retention ponds, closed basin ponding, riverine and sheetflow flooding, and dam or reservoir containment failure may have on an occupied EHPA.

An essential performance requirement of hurricane evacuation shelters is that they not be inundated by rainfall flooding. For design purposes, the Division recommends that the EHPA’s civil designer consider the effects of an extraordinary event on the site drainage design. The designer should assume pre-hurricane saturated soil conditions and at-capacity drainage retention structures, then apply a hurricane-caused single-day rainfall event of about 30 inches. This is approximately a point maximum 2,000-year, 24-hour recurrence rainfall rate (1 sq.mi. basin) for most of Florida, so a low probability event.

#### **G.4 Hurricane evacuation shelter Capacity**

A minimum of fifty percent of the net square feet of certain types of rooms and spaces (referred to as “included spaces”) of new educational facilities are required to be constructed to meet the EHPA criteria. The calculated EHPA capacity is used by board staff, emergency managers and design professionals to determine the shelter occupant capacity and infrastructure-related requirements (potable water, toilets, sinks, parking, etc.) EHPA’s may be located in a single large room or a combination of rooms, located on one or more stories, and possibly in more than one building. To begin the EHPA capacity calculation process, identify those rooms or spaces that are to be excluded. Section 423.25.3.1, FBC and s. 252.385(4)(b), F.S. serve as guides for identifying excluded space.

The following is a summary of the excluded spaces:

**Excluded Spaces.** Spaces such as mechanical, plumbing, electrical, telecommunication and information technology utility equipment rooms, storage rooms and closets, exterior/outside circulation and corridors, restrooms and



shower areas, kitchen and food preparation rooms, science labs, computer and information technology labs, vocational and industrial technology labs and shops, library and media rooms and labs, administrative office and support areas, record vaults, attics and crawl spaces.

**Included Spaces.** All other rooms and areas not listed as an excluded space.

To determine the net square feet of EHPA floor area, subtract the floor area square feet of excluded spaces from the gross square feet of the facility. The board, with the concurrence of the local emergency management agency or the Division may adjust the list of excluded/included spaces or the formula for calculation of design capacity.

To be consistent with the Division's statewide hurricane evacuation shelter survey and retrofit program, the capacity of an EHPA may be based upon "net usable floor area" in-lieu of net floor area. Net usable floor area is defined as follows:

**Net Usable Floor Area.** Floor area of included spaces reduced to account for partitions and walls, columns, fixed or movable objects, furniture, equipment or other features that under probable conditions cannot be removed or stored during use as a hurricane evacuation shelter.

The following empirical reduction factors can be used to determine net usable floor area:

1. Reduce the gross floor area of assembly areas with concentrated furnishings or fixed seating by 50 percent. Examples are auditoriums, amphitheater classrooms, etc. To calculate a room's net usable floor area, multiply gross floor area by a **reduction factor (RF)** of 0.50.
2. Reduce the gross floor area of assembly areas with unconcentrated furnishings and without fixed seating by 35 percent. Examples are conference rooms, educational classrooms and skills labs, dining areas, band and music rooms, etc. To calculate a room's net usable floor area, multiply gross floor area by a RF of 0.65.
3. Reduce the gross floor area of assembly areas with open floors and without fixed seating by 15 percent. Examples are gymnasiums, dance floors, exhibition galleries, open multipurpose rooms, interior/inside circulation corridors and areas, etc. Retractable seating is not considered fixed seating. To calculate a room's net usable floor area, multiply gross floor area by a RF of 0.85.

A more comprehensive list of Department of Education room design codes, descriptions and RFs is available in Appendix H. Reduction values listed are empirical in that they are based upon large-scale typical conditions. Boards, local emergency management agencies and design professionals may adjust the empirical reduction factors to address site-specific conditions.

The capacity of an EHPA is calculated using 20 square feet per occupant. The FBC formula is as follows:

$$\text{(Gross Floor Area, sq.ft. - } \Sigma \text{ Excluded Floor Areas, sq.ft.)} / 20 = \text{Occupant Capacity}$$

To calculate occupant capacity based upon net usable floor area, the formula is:

$$\Sigma \text{(Included Gross Floor Areas, sq.ft. x RF)} / 20 = \text{Usable Occupant Capacity}$$

The designer should be aware that SpNS “client” occupant capacity is based upon 60 square feet per client. The 60 square feet includes an allowance for care-givers, medical staff, medical equipment and supplies, and a cot or bed. Therefore, no additional space allowance is required for these personnel, equipment or material.

It should be noted that in an emergency, on a short-term basis during hurricane conditions, the American Red Cross and emergency management officials may temporarily reduce the occupant floor area requirement to 15 square feet per occupant. This emergency contingency measure does not affect the EHPA criteria’s requirement to use 20 square feet per occupant to calculate design capacity.

The designer should be aware that for adults and children with certain functional or access needs support services (FNSS), such as persons that need wheelchairs or scooters, lift equipment, service animal and/or personal assistance services, FEMA recommends a floor space allocation of 100 sq.ft. For design or planning purposes, the larger accessibility accommodation space may apply to one (1) of every 10 occupants. In some cases the 100 sq.ft. may be shared with a caregiver (i.e., 50 sq.ft. for two of 10 occupant spaces). Additional guidance on space layout considerations can be found in Appendix F and at the following web address:

[www.ct.gov/demhs/lib/demhs/space\\_\\_layout\\_considerations.pdf](http://www.ct.gov/demhs/lib/demhs/space__layout_considerations.pdf)

To estimate the number of design occupants assuming one (1) FNSS space per 10 occupants, the designer can replace the 20 sq.ft. allowance of the EHPA criteria with 28 sq.ft. Assuming that FNSS space is shared by a caregiver, replace 20 sq.ft. with 26 sq.ft. These will reduce the facility’s occupant capacity to account for the additional functional needs space. However, the EHPA code provisions do not permit use of the larger design occupant allowance. Therefore, 20 sq.ft. should be used to calculate mechanical, electrical and plumbing related design features.

The EHPA design provisions focus on a facility’s use as a public hurricane evacuation shelter. Evacuation shelters are typically occupied for a period beginning about 24 to 36 hours prior to landfall (H-24 hours) of a tropical storm or hurricane through about 72 hours after landfall (H+72 hours). Given the relatively limited time the facility is occupied for the evacuation and immediate response phase of emergency operations, floor area allowances can be minimized to that used in the EHPA design criteria (20 net usable sq.ft. per design occupant).

For planning and guidance purposes only, Table G-3 provides the Division's recommendations for calculating the number of occupants of both evacuation and extended duration shelter types. The floor area allowances apply to all sizes of shelters from small with design occupants of less than 50 to mega-shelters with thousands of occupants. The allowances also include additional accommodation space for persons needing FNSS. The definitions for the shelter types can be found in Appendix E, Glossary. To use Table G-3 (below), replace the code value of "20" in the Occupant Capacity formula(s) given previously with values shown in Table G-3. The calculated occupant capacity will provide the number of occupants with a reduction for FNSS spaces. As an example, a risk evacuation shelter with a total of 10,000 gross sq.ft. of floor area and 0.85 reduction factor, replace the "20" with "26" as follows:

$$(10,000 \times 0.85) / 26 = 326 \text{ occupant spaces}$$

Of the 326 total occupant spaces, two of 10 (or 2:10) are based on 50 sq.ft. each (65 FNSS spaces), and the remaining eight of 10 (8:10) are based on 20 sq.ft. each (261 code minimum/standard spaces).

<b>Table G-3. Florida Shelter Occupant Space Calculation Recommendations with FNSS for Dormitory Areas</b>		
<b>Type of Shelter (Duration of Shelter Occupancy)</b>	<b>Floor Area Minimum Recommendation, net usable sq.ft.</b>	<b>Floor Area Range, net usable sq.ft.</b>
<b>General Population</b>		
Risk Evacuation Shelter (0-72 hours)	26	22-46
Host Evacuation Shelter (0-72 hours)	26	26-46
Standard/Short Term Shelter (72 hours - 2 weeks)	42	42-64
Long Term Shelter (more than 2 weeks)	60	60-82
<b>Special Needs Population</b>		
Risk Evacuation Shelter (0-72 hours)	60	60-82
Host Evacuation Shelter (0-72 hours)	60	60-82
Standard/Short Term Shelter (72 hours - 2 weeks)	80	80-100
Long Term Shelter (more than 2 weeks)	100	100-120

### **G.5 Plumbing and Sanitation**

It is essential that the EHPA remain a safe and sanitary environment. The plumbing and sanitary provisions of the EHPA criteria are primarily based upon the American Red Cross's publication *Mass Care Standards and Indicators, Version 011-072209* (Mass Care Standards). Mass care Standards requires that emergency shelters, regardless of cause(s) necessitating their need, provide a minimum level of service.

In general, support systems for toilets, sinks and other essential water distribution and disposal systems are required to be capable of supplying water and containing waste for the design capacity of the EHPA. Plumbing and valve systems of toilets and sinks

within the EHPA may be designed for conversion to emergency operation to meet the required demand. The method selected to achieve the required level of performance is at the discretion of the board, design professionals and emergency management agencies.

It should be noted that EHPA plumbing and sanitation design requirements should not be reduced for pre-designated SpNS facilities. SpNS client capacity is calculated based on 60 sq.ft. per client instead of the 20 sq.ft. used for the general population. This may give the appearance of a reduced design load for critical support systems. However, the 60 sq.ft. includes an allowance for care-givers and the additional medical service staff necessary for operating the shelter. Therefore the plumbing and sanitary systems must be designed to accommodate a loading condition similar to that found in general population shelters.

**G.5.1 Potable Water.** Neither the EHPA criteria nor Mass Care Standards specify a minimum potable water requirement. ICC 500 design standards require a minimum of one (1) gallon of potable water per person for all uses (i.e., drinking water, hygiene, food preparation, etc.) The Division doesn't recommend a potable water design of less than one (1) gallon (3.8 liters or 0.133 cubic feet) per person for all uses. A minimum of two quarts (1/2 gallon or 2 liters) per person should be for drinking water purposes. As an example, an EHPA with a design occupant capacity of 250 persons (includes both evacuees and management staff) will require a minimum of 250 gallons (950 liters or 33.3 cubic feet) of potable water. This is a relatively small quantity of water if it must be extended for more than 24 hours, so conservation measures are recommended (i.e., identify and provide access to sources for clean non-potable water for toilet flushing and certain other hygiene activities, etc.)

It should be noted that both the shelter environment (temperature and humidity) and physical condition/health of evacuees (e.g., age, diet, medications, pregnancy/nursing, etc.) can significantly affect drinking water needs. Table G-4 can be used as a guide to estimating minimum drinking water needs as shelter temperatures rise. A potable water design of 3 to 5 gallons per occupant per day may be more appropriate.

<b>Table G-4. Estimate of Minimum Daily Drinking Water Needs in Unconditioned Shelters</b>			
<b>Shelter's Daily Mean Temperature, °F</b>	<b>Daily Drinking Water Needs<sup>1</sup>, quarts (liters)</b>		
	<b>Normal Demand (normal activity or at rest)</b>	<b>Moderate Demand (moderate work load)</b>	<b>High Demand (hard work load)</b>
<b>70 °F</b>	2 (1.9)	3 (2.8)	5 (4.7)
<b>80 °F<sup>2</sup></b>	3.5 (3.3)	5 (4.7)	7.5 (7.1)
<b>90 °F<sup>3</sup></b>	6 (5.7)	8.5 (8.0)	11.5 (10.9)
<b>100 °F<sup>4</sup></b>	8.5 (8.0)	12 (11.4)	15 (14.2)

<sup>1</sup> - Source: *Medical Aspects of Harsh Environments, Volume 1*, 2001, Chapter 1 Introduction to Heat-related Problems in Military Operations, Figure 1-3  
<sup>2</sup> - Caution: 80 - 90°F Fatigue possible with prolonged exposure  
<sup>3</sup> - Extreme Caution: 90 - 105°F Heat exhaustion possible with prolonged exposure  
<sup>4</sup> - Danger: 105°F or higher; Heat stroke possible with prolonged exposure

The potable water can be provided by on-site wells or water treatment package plants, stored in a permanent flow-through tank, or less preferably, stored in temporary containers or bladders. Temporary systems will be infrequently used (possibly less than once a year), they will require regular maintenance to ensure operational viability. Large volume tanks must also be monitored to assure sufficient chlorine residual. Systems that rely on pumps or other electro-mechanical equipment or devices will require a back-up power supply.

In some circumstances, an alternative to large volume tank storage, and its associated plumbing and valve systems, is on-demand delivery of potable water. If this approach is used, the EHPA will need a delivery and protected storage area for the bulk water. This approach has significant benefits and drawbacks. The benefits are minimal (or no) construction costs associated with this approach, and there are no recurring maintenance or contamination concerns. The drawbacks are logistical and financial: who is going to be responsible for ordering, receiving, distributing, paying for, and if necessary, disposing of the water in time of need? These issues are not show-stoppers, but require a written agreement to assure operational viability.

**G.5.2 Toilets and Sinks.** The EHPA criteria require one (1) toilet and one (1) sink per 40 occupants of design capacity. The toilets and sinks can be fixed units incorporated into the EHPA during design and construction, or less preferably portable/temporary toilets and hand washing facilities. The EHPA required toilets and sinks are not in addition to those required for normal school occupancy, and are to be included in the overall facility fixture count. Generally there are sufficient quantities of toilets and sinks required for normal school occupancy capacity to meet the EHPA requirement. The designer will need to consider placement of the fixtures such that the needs of both the normal school occupancy and the EHPA requirements are served.

EHPA required toilets and sinks must be available (or reachable) from within the protected area, or must be available via a protected passageway that meets the EHPA criteria. Portable chemical toilets may also require separation from occupied spaces and circulation of fresh air. Also, consider how a portable toilet will be delivered, serviced and removed from the facility. This may require a larger door opening than normal and the use of removable door frame mullions.

For adults with certain functional or access needs, low-profile toilets, sinks and grab bars installed in elementary classroom water closets and toilet rooms may be inadequate. The Division recommends that the designer incorporate permanent or adaptive structural and fixture size elements that can safely and expediently accommodate adults with functional or access needs. The adult toilets may also be incorporated into the design by adding adult restrooms into EHPA floor plan.

It should be noted that Mass Care Standards recommends that on average there be one toilet and hand washing sink per 20 persons.

**G.5.3 Showers.** Given that the EHPA criteria assume only an 8-hour occupancy, Mass Care Standards' normal shower requirement can be relaxed. Therefore, showers are not an EHPA code requirement. However, boards and design professionals should consider that in a post-hurricane recovery environment, Mass Care Standards normally require one (1) shower per 25 occupants.

**G.5.4 Wastewater.** The EHPA criteria require that the plumbing system be capable of containing (or otherwise disposing of) the wastewater generated by the design capacity occupant load. During the 2004 and 2005 hurricane seasons, about 30 percent of occupied hurricane evacuation shelters experienced wastewater/sewage back-up into the facility. It is critical that wastewater be prevented from backing up into the EHPA. This can be accomplished through installation of storage tanks, a wastewater treatment package plant, or other suitable measure.

For those facilities with an on-site wastewater lift station, the lift station reservoir can be sized to meet the storage requirement. The lift station reservoir must be set at a lower elevation than the EHPA to prevent back-up of wastewater into the shelter area. The lift station should also be equipped with an emergency back-up power system to support drainage into the local utility system. As a contingency, the stored wastewater can be drained and properly disposed of by a mobile pump unit.

Instead of a tank, an alternative is to utilize the waste drain pipe as the storage container. In this method, the pipe is over-sized to accommodate the required volume of waste on the facility side of the back-flow preventer. Wastewater and sewage back-up is normally caused by continued disposal (or flushing) of wastewater into the drain pipe system after the utility side back-flow preventer has closed; the drain pipe has insufficient capacity for continued use. With an over-sized drain pipe, the waste is stored in the pipe until the utility system is restored. A drainage connection or fixture should be incorporated into the drain pipe to accommodate expedient drainage and proper disposal by a mobile pump unit.

The Division recommends that the wastewater system design be based upon a ratio of 1.5 gallons wastewater for every gallon of potable water. In addition to the basic potable water design volume, the 1.5:1 ratio provides extra capacity for solid materials and introduction of non-potable water into the system (e.g., toilet flushing). Thus, based upon a minimum recommended potable water load of 1 gallon per occupant, the minimum recommended wastewater capacity is 1.5 gallons (0.2 cubic feet) per occupant. The Division recommends that the reservoir capacity be based upon a 24-hour design occupant capacity instead of the 8-hour design capacity (i.e., 5 gallons per occupant instead of 1 gallon). As an example, an EHPA with a design occupant capacity of 250 persons (includes both evacuees and management staff) will require a minimum wastewater storage capacity of 1,250 gallons (166.7 cubic feet).

**G.5.5 Garbage Disposal.** The Division recommends that janitorial service areas be located within the EHPA, and provisions be considered for temporary storage or disposal of solid wastes and garbage. Mass Care Standards recommends one (1) 30 gallon waste receptacle/container with lid and trash bags for every 10 persons.

## **G.6 Electrical and Standby Emergency Power System**

Back-up and emergency power provisions are an important feature for hurricane evacuation shelters. Utility electrical power can be disrupted for a few hours to several days (or possibly weeks) following arrival of hurricane conditions. During a utility electrical power outage, EHPA's must remain a safe and sanitary environment. Life-safety systems must continue to function, minimal lighting must be provided to support safe movement, security and emergency egress needs, and adequate ventilation provided to maintain a habitable environment.

At a minimum, the EHPA criteria require installation of an emergency electrical power system with an outlet for coupling to a back-up portable generator. The EHPA criteria do not require installation of a permanent electrical power generator, but rely on emergency battery power and "pre-wiring" the facility's electrical system to accept expeditious and safe installation of a compatible portable generator. Therefore, the minimum EHPA requirement relies upon on-demand delivery of a compatible electrical power generator. If the on-demand approach is used, the EHPA will need a protected storage area for the generator.

The on-demand approach has significant benefits and drawbacks. The benefits are reduced initial construction costs, minimal recurring maintenance expenses and no fuel-degradation concerns. The drawbacks are logistical and financial: who is going to be responsible for ordering, receiving, installing, maintaining, refueling, redeploying and paying for the generator in time of need? Very few, if any, boards or local government agencies possess an adequate quantity of compatible portable generators to meet EHPA requirements. Also, state and federal agencies do not normally deploy portable emergency power generators until at least 24 hours after impact by hurricane conditions, and in many cases it may be more than 72 hours. These issues are not show-stoppers, but require emergency power provisions be included in board and local facilities and emergency operations plans (and possibly a written agreement) to assure operational viability.

Boards and design professionals must note that state and local emergency management agencies are under no statutory or code obligation to provide portable emergency generator(s) for EHPA's. Boards and design professionals are responsible for developing an appropriate EHPA emergency power capability to maintain a safe and sanitary environment for at least the required 8-hour minimum design occupant capacity.

For facilities that are pre-designated to serve as SpNS facilities, the Division strongly recommends that the standby emergency power system be designed to accommodate additional branch circuits to support medical equipment, refrigeration of medical supplies and air-conditioning of client occupied areas. These special requirements may exceed basic EHPA design criteria, but post-construction retrofitting to accommodate these requirements is often difficult and costly. The Division strongly encourages the designer to coordinate with local emergency management and county health department staff when designing a facility that is pre-designated as a SpNS.

## **G.7 Emergency Management Considerations**

**G.7.1 Shelter Manager's Office.** The EHPA criteria require that an administrative office be identified for shelter management use and included within the EHPA. The office is required to have provisions for standby power, lighting, communications, main fire alarm control panel and storage for the manager's equipment. Communications may include both internal (within the EHPA) and external (to outside shelter support agencies) communications.

The EHPA criteria do not specify a minimum floor area requirement for shelter management needs. ARC 4496 recommends that shelter management functions be based upon a minimum of 40 square feet per staff person. Therefore, the Division recommends that the shelter manager's office be a minimum of 40 square feet of net floor area, and an additional 40 square feet per assistant manager(s), communications person(s) and equipment storage. As an example, assuming the shelter manager and assistant manager occupy a single office area with equipment storage, the shelter manager's office should have about 120 net square feet of floor area (i.e., 40 sq.ft. x 3 management functions = 120 sq.ft.) The communications person(s) may be located in adjacent spaces.

**G.7.2 Signage.** A sign with a floor plan drawing or image indicating the EHPA's location and perimeter boundaries or limits is required to be mounted in the shelter manager's office.

**G.7.3 Food Service.** The EHPA criteria states that "where feasible, include counter tops for food distribution functions in the EHPA's." Mass Care Standards requires that emergency shelters have a feeding area and a means of storing, preparing and distributing food (and concurrently drinking water). Ideally, for sanitation purposes, emergency managers and shelter support agencies prefer to have feeding-related areas separate from general population areas. However, to maximize utilization of the EHPA's floor area during hurricane conditions, this preference can be relaxed and feeding areas occupied by a shelter population.

Mass Care Standards normally requires 2,000 calories per person per day (about three pounds of unprepared food). However, on a temporary basis, a hurricane evacuation shelter's feeding services can be relaxed. For design purposes, the EHPA planning assumption is 8-hours, or one-third (1/3) of a day. Therefore, at a minimum the Division recommends that boards and design professionals plan for distribution of about one-third of the ARC's daily requirement, or about 667 calories (about one pound per person). This minimum feeding requirement can be met via "bag lunches" or heavy snacks. As an example, an EHPA with a design occupant capacity of 250 persons (includes both evacuees and management staff) should have a minimum of 250 pounds of food. Given that bag lunches and one-quart containers of bottled water can be distributed from a movable table (or straight out of bulk delivery boxes or containers), a fixed counter top may not be required; thus the "where feasible" preface in the code.



**G.7.4 Supplemental Space Allocations.** Ideally, in addition to shelter management space needs, adequate space should be set aside within the EHPA for registration, emergency medical care, safety and fire considerations, janitorial services and sanitation. For post-hurricane recovery shelter operations, Mass Care Standards also recommends addition of space for storage of bulk food and supplies, food preparation and feeding, separate rooms for general population, elderly and families with small children, sleeping areas, recreation, and possible storage of occupants' belongings.

**G.7.5 Parking.** EHPA vehicle parking areas may be paved or unpaved, but must be located more than 50 feet from the EHPA.

**G.8 Americans with Disabilities Act Shelter Requirements.** The Americans with Disabilities Act (ADA) requires shelters to provide equal access and service to all persons. For guidance on surveying accessibility of emergency shelters please see Appendix L. Additional guidance can be found in *Guidance on Planning for Integration of Functional Needs Support Services in General Population Shelters* (FEMA, November 2010), which can be found at the following web address:

[http://www.fema.gov/pdf/about/odc/fnss\\_guidance.pdf](http://www.fema.gov/pdf/about/odc/fnss_guidance.pdf)

**G.9 Comparison of Florida's EHPA to the International Code Council's ICC 500**  
The ICC 500 was published in August, 2008 and so will become a consideration for design of hurricane evacuation shelters. Florida's EHPA code provisions were considered during preparation of ICC 500 so there are many design consistencies between them. However, the objective of the ICC storm shelter committee was to ensure a high-degree of safety for shelter occupants. Therefore, wind design provisions are based on a near-ultimate hurricane event. Table G-5 provides a comparison of Florida's EHPA criteria and ICC 500.

<b>Table G-5. Comparison of Florida Building Code's Public Shelter Design Criteria (EHPA) and the International Code Council's ICC 500 Hurricane Shelter Standard</b>		
<b>Design Criteria</b>	<b>2010 FBC—Building, EHPA</b>	<b>ICC 500—2008, Hurricane Provisions</b>
<b>2010 Florida Building Code-- Building References</b>	Section 423.25	Section 442
<b>Design Occupancy Period</b>	8 hours	24 hours
<b>Net Usable Floor Space per Occupant</b>	20 sq.ft. all adults and children	20 sq.ft. for standing, seated or wheelchair; 40 sq.ft. for bedridden
<b>Sanitary Facilities</b>	Toilets 1:40 Handwashing 1:40	Toilets 1:50 Handwashing 1:100

<b>Table G-5. Comparison of Florida Building Code's Public Shelter Design Criteria (EHPA) and the International Code Council's ICC 500 Hurricane Shelter Standard</b>		
<b>Design Criteria</b>	<b>2010 FBC—Building, EHPA</b>	<b>ICC 500—2008, Hurricane Provisions</b>
<b>Potable Water Capacity, minimum</b>	No Capacity Given	1 Gallon per Occupant
<b>Wastewater Capacity, minimum</b>	No Capacity Given	1.5 Gallons per Occupant
<b>Flood Design Criteria</b>	ASCE 7 and ASCE 24	ASCE 7 and ASCE 24
<b>Storm Surge Flood Elevation (if applicable)</b>	EHPA must be located outside Cat. 1, 2 or 3 evacuation zones. EHPA floor slab must be elevated above maximum inundation of a Category 4 hurricane.	No limitation on location of hurricane shelter in storm surge evacuation zones. Lowest floor slab must be elevated above maximum inundation of a Category 5 hurricane.
<b>Inland Rainfall Flooding</b>	Floor slab of lowest finished floor must be elevated above base flood elevation plus two (2) feet.	Lowest floor slab of occupied shelter must be elevated to the higher of the following elevations at the site: 1) flood having 0.2% annual chance; 2) flood elevation having 1% annual chance plus two (2) feet; and 3) if not in mapped special flood hazard area, flood elevation of the highest recorded flood elevation plus two (2) feet
<b>Rain Loads</b>	Roofs shall have adequate slope and drains for normal use and shall have emergency overflow; (100-year recurrence interval for both normal and emergency overflow; no additional rainfall rate capacity given)	ICC 500, Section 303.1 (100-year recurrence interval normal drains, and 100-year plus 3 inch per hour overflow; ranges from total of 7.3 to 8 inch emergency overflow capacity for Florida)
<b>Hurricane Wind Load Design</b>	ASCE 7	ASCE 7 with modifications
<b>Minimum Design Wind Speed</b>	ASCE 7 Risk Category IV map wind speed (1,700 year recurrence)	ICC 500 Hurricane Wind Speed Map (10,000-year recurrence)
<b>Importance Factor, <i>I</i></b>	Not Applicable	1.00
<b>Directionality Factor, <i>K<sub>d</sub></i></b>	0.85	1.00
<b>Optional Increase in Design Wind Speed</b>	ASCE 7 Risk Category IV, plus 40 mph recommended; recommendation adjusts design wind speed upwards to approx. 5,000 to 10,000-year recurrence interval	Not Applicable

<b>Table G-5. Comparison of Florida Building Code's Public Shelter Design Criteria (EHPA) and the International Code Council's ICC 500 Hurricane Shelter Standard</b>		
<b>Design Criteria</b>	<b>2010 FBC—Building, EHPA</b>	<b>ICC 500—2008, Hurricane Provisions</b>
<b>Exposure</b>	ASCE 7	ASCE 7 Exposure C (Exposure B may be applied to MWFRS in certain situations)
<b>Enclosure Classification</b>	ASCE 7	ASCE 7 with largest door or window on each side individually considered an opening (breach)
<b>Load Combinations</b>	ASCE 7	ASCE 7 with reductions per ICC 500 Chap. 3
<b>Building Enclosure Missile Impact Criteria (all surfaces)</b>	ASTM E-1886 and ASTM E-1996 or SBC/SSTD 12 (large missile: 9 lb 2x4 @ 34 mph)	ASTM E 1886 and E 1996 with modifications (large missile: 9 lb 2x4 Vertical Surface=0.4*Design Wind Speed Horizontal Surface=0.1*Design Wind Speed)
<b>Impact Testing Procedures</b>	ASTM E-1886 and ASTM E-1996 or SBC/SSTD 12	ASTM E 1886 or E 1996 as modified by ICC 500 Chap. 8
<b>Weather Protection (rainwater intrusion)</b>	Exterior envelope and air intakes/vent assemblies must meet design wind loads; Roof covering to be specified and designed to meet wind uplift forces and meet ASTM and Factory Mutual Standards	All exterior components and cladding assemblies and roof coverings must be designed and installed to meet design wind loads
<b>Fire Separation</b>	Applicable Code	Applicable Code plus 2 hour fire resistance rating of walls/assemblies that separate shelter areas from the host building
<b>Natural Ventilation</b>	S. 423.13.8.1, FBC—Building (5 % of internal floor area as net free open area equivalent in exterior walls of rooms on perimeter of building, with exceptions)	12 net sq.in. of vent area openings per occupant
<b>Mechanical Ventilation</b>	2 cfm per sq.ft. of EHPA floor area (i.e., 40 cfm per occupant)	Ventilation rate determined by applicable building code for normal use of space (typically 15 cfm per occupant)
<b>Emergency Lighting</b>	FBC	1 foot-candle
<b>Standby Lighting</b>	10 foot-candles	10 foot-candles
<b>Standby Emergency Power System, minimum loads</b>	Required; minimum loads: emergency lighting, illuminated exit signs, fire protection and alarm systems, four (4) electrical receptacles in shelter manager's office	Required; minimum loads: standby lighting and life safety/fire protection and alarm systems

<b>Table G-5. Comparison of Florida Building Code's Public Shelter Design Criteria (EHPA) and the International Code Council's ICC 500 Hurricane Shelter Standard</b>		
<b>Design Criteria</b>	<b>2010 FBC—Building, EHPA</b>	<b>ICC 500—2008, Hurricane Provisions</b>
<b>Standby Emergency Power System, optional loads</b>	1. Remainder of the school's campus security lighting (building and site); 2. Additional ventilation circuits; 3. Intercom system; 4. Food storage equipment; and 5. Additional electric receptacles	Not Applicable
<b>Permanent Standby Electric Generator</b>	Not Required	Not Required
<b>Special Inspections</b>	EHPA's are designated "threshold buildings" and subject to special structural inspections	Community shelters are subject to special inspections and structural observations
<b>Peer Review</b>	Not Required	Construction documents for community shelters with design occupancies greater than 300 are subject to peer review

**Appendix H:**

Hurricane Evacuation Shelter Net Usability Multiplication Factor  
Estimates for Florida Department of Education Facilities

Hurricane Evacuation Shelter Net Usability Multiplication Factor Estimates for Florida Department of Education Facilities				
Design Code Number	Design Description	Minimum Room sq.ft.	Normal sq.ft. per student	Net Usability Factor
00001	Primary Classroom (K-3)	600	40	0.50
00002	Intermediate Class ( 4-8)	600	39	0.65
00003	Senior High Class (9-12)	600	32	0.65
00004	Intermediate Class	608	32	0.65
00005	Elementary Resource	416	32	0.65
00007	Elementary Foreign Language Lab	608	32	0.65
00008	Elementary Math Skills Lab	608	32	0.65
00009	Elementary Social Studies Lab	608	32	0.65
00010	Primary Skills Lab (K-3)	600	49	0.65
00011	Intermediate/Middle Skills Lab (4-8)	600	39	0.65
00012	Senior High Skills Lab (9-12)	600	32	0.65
00015	Elementary Open Plan Area	1,920	32	0.65
00021	Middle/Jr High Resource	416	32	0.65
00023	Middle/Jr High Foreign Lang Lab	608	32	0.65
00024	Middle/Jr High Math Skills Lab	608	32	0.65
00025	Middle/Jr High Social Studies Lab	608	32	0.65
00026	Middle/Jr High Lang Arts Labe	608	32	0.65
00029	Middle/Jr High Art Lab	630	42	0.50
00030	Primary Open Plan (K-3)	1,368	38	0.65
00031	Intermediate/Middle Open Plan (4-8)	1,408	32	0.65
00032	Senior High Open Plan (9-12)	1,600	27	0.65
00035	Senior High Class	513	27	0.65
00036	Senior High Resource	416	32	0.65
00038	Senior High Foreign Lang Lab	512	32	0.65
00039	Senior High Math Skills Lab	512	32	0.65
00040	Resource Room	290	29	0.65
00041	Senior High Lang Arts Lab	512	32	0.65
00047	Senior High Art Lab	530	53	0.50
00050	Art – Elementary	600	37	0.50
00051	Art – Middle	630	42	0.50
00052	Art – Senior High	530	53	0.50
00060	ESE Special Class (Part Time)	650	65	0.50
00061	ESE Part-time	600	65	0.50
00062	ESE Full-Time	600	95	0.50
00063	ESE Vocational	600	95	0.50
00064	ESE PT/OT Lab	600	0	0.50
00065	ESE Resource	290	95	0.50

Hurricane Evacuation Shelter Net Usability Multiplication Factor Estimates for Florida Department of Education Facilities				
Design Code Number	Design Description	Minimum Room sq.ft.	Normal sq.ft. per student	Net Usability Factor
00075	Vocal Music Class (Middle-Sr High)	513	57	0.65
00076	Band Class (Middle-Sr High)	1,200	35	0.65
00077	Orchestra Class (Middle-Sr High)	513	57	0.65
00078	General Music Class (Middle-Sr High)	518	37	0.65
00079	Guitar Lab (Middle-Sr High)	518	37	0.65
00110	PE Multipurpose Room (Middle-SrH)	800	0	0.85
00111	Jr High Gym	1	0	0.85
00112	Sr High Gym	1	0	0.85
00113	Gym Seating	1	0	0.85
00118	PE Wrestling Room	402	0	0.85
00119	PE Gymnastics & Dance	420	0	0.85
00340	Dining Area	1	0	0.65
00360	Auditorium	1	0	0.50
00361	Multipurpose Room (Dining)	1	0	0.65
00363	Stage	1	0	0.65
00370	Lobby	1	0	0.85
00700	Inside Circulation	1	0	0.85
00840	Vocational Related Classroom	256	32	0.65

**Appendix I:**

Department of Education Memorandum on “Hurricane Shelters in New Educational Facilities,” dated October 31, 2001





FLORIDA DEPARTMENT OF EDUCATION

**CHARLIE CRIST**  
COMMISSIONER

Wayne V. Pierson  
Deputy Commissioner for  
Planning, Budgeting and Management


October 31, 2001

**CONTACT PERSON**  
NAME: Jon Hamrick  
PHONE: (850) 487-1130  
SUNCOM: 277-1130

DPBM No.: 02-42

MEMORANDUM

TO: District School Superintendents, Community College Presidents, and Educational Facilities Planners

FROM: Wayne V. Pierson 

SUBJECT: Hurricane Shelters in New Educational Facilities

The Department of Education has again been asked to reiterate the requirement that all construction of new educational facilities, including appropriate core facility additions to existing buildings, incorporate enhanced hurricane protection areas in their design. Section 235.26(8)(a), F.S., states the following:

“A facility, or an appropriate core facility area within a facility, for which a design contract is entered into subsequent to the effective date of the inclusion of the public shelter criteria in the code must be built in compliance with the amended code unless the facility or a part thereof is exempted from using the new shelter criteria due to its location, size, or other characteristics by the applicable board with the concurrence of the applicable local emergency management agency or the Department of Community Affairs. Any educational facility located or proposed to be located in an identified category 1, 2, or 3 evacuation zone is not subject to the requirements of this subsection. If the regional planning council region in which the county is located does not have a hurricane evacuation shelter deficit, as determined by the Department of Community Affairs, school districts within the planning council region are not required to incorporate the public shelter criteria into their construction of educational facilities.”

11/13/2001 15:59 850-488-1577

ED FAC

PAGE 03

DBPM No. 02-42  
October 31, 2001  
Page 2

The State Requirements for Educational Facilities, Section 7(24)(a), and the Florida Building Code, Section 423(24)(a), provides:

“New educational facilities for school boards and community college boards, unless specifically exempted by the board with the written concurrence of the applicable local emergency management agency or the Department of Community Affairs (DCA), shall have appropriate core facility areas designed as Enhanced Hurricane Protection Areas (EHPAs) in compliance with this section.”

New educational facilities have been interpreted to mean “new construction,” as defined in Section 1.2(56), SREF, and Section 423(4)(h), Florida Building Code, which includes additions to existing buildings. There are three exceptions: 1) if the new work is specifically exempted in writing by the applicable local emergency management agency, 2) if the new building(s) or addition is located in a category 1, 2, or 3 evacuation zone, and 3) if the local regional planning council region does not have a shelter deficit. The exception for one shelter within a three-mile radius no longer exists.

It is imperative that shelter space be provided in all appropriate new educational facilities so that the deficit in shelter space can be eliminated. In this light, you are encouraged to work with your county emergency management office prior to or during the development of a project to identify appropriate shelter space. The additional cost directly associated to the Enhanced Hurricane Protection Area (EHPA) is deducted from the total construction cost when applying for a SIT award.

Please note that the October 2001 Audit Report Number 02-055 for Hurricane Shelters and Grant Management for the Department of Community Affairs has identified a lapse in enforcement of the shelter criteria by school districts and community colleges. Of the 164 constructed or newly planned facilities examined by the auditor, one-third did not comply with the required shelter requirements.

WVP/jhi



[Online Sunshine](#)
[Welcome](#)
[Session](#)
[Committees](#)
[Legislators](#)
[Information Center](#)
[Statutes & Constitution](#)
[Lobbyist Information](#)

[View Statutes](#)
[Search Statutes](#)
[Constitution](#)
[Laws of Florida](#)
[Order](#)

Select Year:

**The 2001 Florida Statutes**

[Title XVI](#)                      [Chapter 235](#)                      [View Entire Chapter](#)  
 Education                      Educational Facilities

**235.26 State uniform building code for public educational facilities construction.--**

(1) UNIFORM BUILDING CODE.--By July 1, 2001, a uniform statewide building code for the planning and construction of public educational and ancillary plants by district school boards and community college district boards of trustees shall be adopted by the Florida Building Commission within the Florida Building Code, pursuant to s. 553.73. Included in this code must be flood plain management criteria in compliance with the rules and regulations in 44 C.F.R. parts 59 and 60, and subsequent revisions thereto which are adopted by the Federal Emergency Management Agency. It is also the responsibility of the department to develop, as a part of the uniform building code, standards relating to:

- (a) Prefabricated facilities or factory-built facilities that are designed to be portable, relocatable, demountable, or reconstructible; are used primarily as classrooms; and do not fall under the provisions of ss. 320.822-320.862. Such standards must permit boards to contract with the Department of Community Affairs for factory inspections by certified building code inspectors to certify conformance with applicable law and rules. The standards must comply with the requirements of s. 235.061 for relocatable facilities intended for long-term use as classroom space, and the relocatable facilities shall be designed subject to missile impact criteria of s. 423(24)(d)(1) of the Florida Building Code when located in the windborne debris region.
- (b) The sanitation of educational and ancillary plants and the health of occupants of educational and ancillary plants.
- (c) The safety of occupants of educational and ancillary plants as provided in s. 235.06, except that the firesafety criteria shall be established by the State Fire Marshal in cooperation with the Florida Building Commission and the department and such firesafety requirements must be incorporated into the Florida Fire Prevention Code.
- (d) Accessibility for children, notwithstanding the provisions of s. 553.512.
- (e) The performance of life-cycle cost analyses on alternative architectural and engineering designs to evaluate their energy efficiencies.
  1. The life-cycle cost analysis must consist of the sum of:
    - a. The reasonably expected fuel costs over the life of the building which are required to maintain illumination, water heating, temperature, humidity, ventilation, and all other energy-consuming equipment in a facility; and
    - b. The reasonable costs of probable maintenance, including labor and materials, and operation of the building.
  2. For computation of the life-cycle costs, the department shall develop standards that must include, but need not be limited to:
    - a. The orientation and integration of the facility with respect to its physical site.
    - b. The amount and type of glass employed in the facility and the directions of exposure.



11/13/2001 15:59

850-488-1677

ED FAC

PAGE 87

- c. The effect of insulation incorporated into the facility design and the effect on solar utilization of the properties of external surfaces.
  - d. The variable occupancy and operating conditions of the facility and subportions of the facility.
  - e. An energy-consumption analysis of the major equipment of the facility's heating, ventilating, and cooling system; lighting system; and hot water system and all other major energy-consuming equipment and systems as appropriate.
3. Life-cycle cost criteria published by the Department of Education for use in evaluating projects.
  4. Standards for construction materials and systems based on life-cycle costs that consider initial costs, maintenance costs, custodial costs, operating costs, and life expectancy. The standards may include multiple acceptable materials. It is the intent of the Legislature to require district school boards to comply with these standards when expending funds from the Public Education Capital Outlay and Debt Service Trust Fund or the School District and Community College District Capital Outlay and Debt Service Trust Fund and to prohibit district school boards from expending local capital outlay revenues for any project that includes materials or systems that do not comply with these standards, unless the district school board submits evidence that alternative materials or systems meet or exceed standards developed by the department.

It is not a purpose of the Florida Building Code to inhibit the use of new materials or innovative techniques; nor may it specify or prohibit materials by brand names. The code must be flexible enough to cover all phases of construction so as to afford reasonable protection for the public safety, health, and general welfare. The department may secure the service of other state agencies or such other assistance as it finds desirable in recommending to the Florida Building Commission revisions to the code.

(2) CONFORMITY TO FLORIDA BUILDING CODE AND FLORIDA FIRE PREVENTION STANDARDS REQUIRED FOR APPROVAL.--

(a) Except as otherwise provided in paragraph (b), all public educational and ancillary plants constructed by a district school board or a community college district board of trustees must conform to the Florida Building Code and the Florida Fire Prevention Code, and such plants are exempt from all other state building codes; county, municipal, or other local amendments to the Florida Building Code and local amendments to the Florida Fire Prevention Code; building permits, and assessments of fees for building permits, except as provided in s. 553.80; ordinances; road closures; and impact fees or service availability fees. Any inspection by local or state government must be based on the Florida Building Code and the Florida Fire Prevention Code. Each board shall provide for periodic inspection of the proposed educational plant during each phase of construction to determine compliance with the state requirements for educational facilities.

(b) A district school board or community college district board of trustees may conform with the Florida Building Code and the Florida Fire Prevention Code and the administration of such codes when constructing ancillary plants that are not attached to educational facilities, if those plants conform to the space size requirements established in the codes.

(c) A district school board or community college district board of trustees may not approve any plans for the construction, renovation, remodeling, or demolition of any educational or ancillary plants unless these plans conform to the requirements of the Florida Building Code and the Florida Fire Prevention Code. Each district school board and community college district board of trustees may adopt policies for delegating to the superintendent or community college president authority for submitting documents to the department and for awarding contracts subsequent to and consistent with board approval of the scope, timeframes, funding source, and budget of a survey-recommended project.

(3) ENFORCEMENT BY BOARD.--It is the responsibility of each district school board and community college district board of trustees to ensure that all plans and educational and ancillary plants meet the standards of the Florida Building Code and the Florida Fire Prevention Code and to provide for the enforcement of these codes in the areas of its jurisdiction. Each board shall provide for the proper supervision and inspection of the work. Each board may employ a chief building official or inspector and such other inspectors, who have been certified pursuant to chapter 468,



11/13/2001 15:59 850-488-1577  
statutes--View Statutes--2001--Ch0235--Section 26: Online Sunshine

ED FAC

PAGE 08

and such personnel as are necessary to administer and enforce the provisions of this code. Boards may also utilize local building department inspectors who are certified by the department to enforce this code. Plans or facilities that fail to meet the standards of the Florida Building Code or the Florida Fire Prevention Code may not be approved. When planning for and constructing an educational, auxiliary, or ancillary facility, a district school board must use construction materials and systems that meet standards adopted pursuant to subparagraphs (1)(e)3. and 4. If the planned or actual construction of a facility deviates from the adopted standards, the district school board must, at a public hearing, quantify and compare the costs of constructing the facility with the proposed deviations and in compliance with the adopted standards and the Florida Building Code. The board must explain the reason for the proposed deviations and compare how the total construction costs and projected life-cycle costs of the facility or component system of the facility would be affected by implementing the proposed deviations rather than using materials and systems that meet the adopted standards. The provisions of this subsection do apply to educational, auxiliary, and ancillary facility projects commenced on or after July 1, 1999.

(4) ENFORCEMENT BY DEPARTMENT.--As a further means of ensuring that all educational and ancillary facilities hereafter constructed or materially altered or added to conform to the Florida Building Code standards or Florida Fire Prevention Code standards, each district school board and community college district board of trustees that undertakes the construction, renovation, remodeling, purchasing, or lease-purchase of any educational plant or ancillary facility, the cost of which exceeds \$200,000, may submit plans to the department for approval.

(5) APPROVAL.--

(a) Before a contract has been let for the construction, the department, the board, or the board's authorized review agent must approve the phase III construction documents. A board may reuse prototype plans on another site, provided the facilities list and phase III construction documents have been updated for the new site and for compliance with the Florida Building Code and the Florida Fire Prevention Code and any laws relating to firesafety, health and sanitation, casualty safety, and requirements for the physically handicapped which are in effect at the time a construction contract is to be awarded.

(b) In reviewing plans for approval, the department, the board, or its review agent as authorized in s. 235.017, shall take into consideration:

1. The need for the new facility.
2. The educational and ancillary plant planning.
3. The architectural and engineering planning.
4. The location on the site.
5. Plans for future expansion.
6. The type of construction.
7. Sanitary provisions.
8. Conformity to Florida Building Code standards.
9. The structural design and strength of materials proposed to be used.
10. The mechanical design of any heating, air-conditioning, plumbing, or ventilating system. Typical heating, ventilating, and air-conditioning systems preapproved by the department for specific applications may be used in the design of educational facilities.
11. The electrical design of educational plants.
12. The energy efficiency and conservation of the design.
13. Life-cycle cost considerations.



14. The design to accommodate physically handicapped persons.
15. The ratio of net to gross square footage.
16. The proposed construction cost per gross square foot.
17. Conformity with the Florida Fire Prevention Code.

(c) The board may not occupy a facility until the project has been inspected to verify compliance with statutes, rules, and codes affecting the health and safety of the occupants. Verification of compliance with rules, statutes, and codes for nonoccupancy projects such as roofing, paving, site improvements, or replacement of equipment may be certified by the architect or engineer of record and verification of compliance for other projects may be made by an inspector certified by the department or certified pursuant to chapter 468 who is not the architect or engineer of record. The board shall maintain a record of the project's completion and permanent archive of phase III construction documents, including any addenda and change orders to the project. The boards shall provide project data to the department, as requested, for purposes and reports needed by the Legislature.

(6) REVIEW PROCEDURE.--The Commissioner of Education shall cooperate with the Florida Building Commission in addressing all questions, disputes, or interpretations involving the provisions of the Florida Building Code which govern the construction of public educational and ancillary facilities, and any objections to decisions made by the inspectors or the department must be submitted in writing.

(7) BIENNIAL REVIEW AND UPDATE; DISSEMINATION.--The department shall biennially review and recommend to the Florida Building Commission updates and revisions to the provisions of the Florida Building Code which govern the construction of public educational and ancillary facilities. The department shall publish and make available to each district school board and community college district board of trustees at no cost copies of the state requirements for educational facilities and each amendment and revision thereto. The department shall make additional copies available to all interested persons at a price sufficient to recover costs.

(8) EDUCATION FACILITIES AS EMERGENCY SHELTERS.--

(a) The Department of Education shall, in consultation with boards and county and state emergency management offices, include within the standards to be developed under subsection (1) public shelter design criteria that shall be incorporated into the Florida Building Code. The new criteria must be designed to ensure that appropriate core facility areas in new educational facilities can serve as public shelters for emergency management purposes. A facility, or an appropriate core facility area within a facility, for which a design contract is entered into subsequent to the effective date of the inclusion of the public shelter criteria in the code must be built in compliance with the amended code unless the facility or a part thereof is exempted from using the new shelter criteria due to its location, size, or other characteristics by the applicable board with the concurrence of the applicable local emergency management agency or the Department of Community Affairs. Any educational facility located or proposed to be located in an identified category 1, 2, or 3 evacuation zone is not subject to the requirements of this subsection. If the regional planning council region in which the county is located does not have a hurricane evacuation shelter deficit, as determined by the Department of Community Affairs, school districts within the planning council region are not required to incorporate the public shelter criteria into their construction of educational facilities.

(b) By January 31, 1996, and by January 31 every even-numbered year thereafter, the Department of Community Affairs shall prepare and submit a statewide emergency shelter plan to the Governor and the Cabinet for approval. The plan must identify the general location and square footage of existing shelters, by regional planning council region, and the general location and square footage of needed shelters, by regional planning council region, in the next 5 years. Such plan must identify the types of public facilities which should be constructed to comply with emergency shelter criteria and must recommend an appropriate, adequate, and dedicated source of funding for the additional cost of constructing emergency shelters within these public facilities. After the approval of the plan, a board may not be required to build more emergency shelter space than identified as needed in the plan, and decisions pertaining to exemptions pursuant to paragraph (a) must be guided by the plan.



(9) LOCAL LEGISLATION PROHIBITED.--After June 30, 1985, pursuant to s. 11(a)(21), Art. III of the State Constitution, there shall not be enacted any special act or general law of local application which proposes to amend, alter, or contravene any provisions of the State Building Code adopted under the authority of this section.

**History.**--s. 926, ch. 19355, 1939; CGL 1940 Supp. 892(312); s. 12, ch. 29754, 1955; s. 10, ch. 59-371; s. 117, ch. 65-239; s. 1, ch. 67-106; ss. 15, 18, 19, 35, ch. 69-106; s. 1, ch. 69-300; s. 1, ch. 70-196; s. 6, ch. 70-399; s. 9, ch. 74-374; s. 1, ch. 77-280; s. 15, ch. 77-458; s. 1, ch. 78-290; s. 1, ch. 79-71; s. 103, ch. 79-400; s. 9, ch. 80-414; ss. 27, 50, 52, ch. 81-223; ss. 10, 14, ch. 82-240; s. 1, ch. 83-163; s. 3, ch. 83-224; s. 1, ch. 84-349; ss. 16, 26, 27, ch. 85-116; ss. 1, 4, ch. 86-1; s. 1, ch. 88-202; s. 5, ch. 89-226; s. 15, ch. 89-278; s. 13, ch. 90-172; s. 11, ch. 90-241; s. 55, ch. 90-288; s. 2, ch. 90-320; s. 169, ch. 92-279; s. 55, ch. 92-326; s. 6, ch. 93-211; s. 6, ch. 94-292; ss. 18, 35, ch. 95-269; ss. 6, 11, ch. 95-341; s. 145, ch. 97-190; s. 6, ch. 97-265; s. 30, ch. 97-384; s. 16, ch. 99-329; s. 2, ch. 2000-140; s. 11, ch. 2000-141; s. 20, ch. 2001-61; s. 34, ch. 2001-186.

[Welcome](#) • [Session](#) • [Committees](#) • [Legislators](#) • [Information Center](#) • [Statutes and Constitution](#)  
• [Lobbyist Information](#)

Disclaimer: The information on this system is unverified. The journals or printed bills of the respective chambers should be consulted for official purposes. Copyright © 2000-2001 State of Florida. [Contact us](#).  
[Privacy Statement](#)

**Appendix J:**

Hurricane Shelter Demand Study Table



**2012 Statewide Emergency Shelter Plan -- Appendix J**

County	RPC Region	2012 Estimated General Population (Source 2010 Regional Evacuation Studies )	2012 Estimated Vulnerable General Population (Does not include Tourist) (Source: 2010 Regional Evacuation Studies)	2012 Estimated General Shelter Demand (w/o PSN) (Source: 2010 Regional Evacuation Studies)	2012 Estimated PSN Shelter Demand (Source: 2010 Regional Evacuation Studies)	2012 Estimated Total Shelter Demand	Planning %tage from Behavioral Survey	2017 Estimated General Population (Source:2010 Regional Evacuation Studies)	2017 Estimated Vulnerable General Population (does not include tourists)	2017 Estimated General Population Shelter Demand (w/o PSN) (Source: 2010 Regional Evacuation Studies)	2017 Estimated PSN Shelter Demand (Source: 2010 Regional Evacuation Studies)	2017 Total Shelter Demand
Bay	1	177,372	134,714	7,328	337	7,665	0.250%	190,616	143,200	7,802	358	8,160
Escambia	1	328,801	153,070	11,209	307	11,516	0.200%	340,395	160,902	12,402	322	12,724
Holmes	1	20,236	9,078	1,026	62	1,088	0.675%	21,083	9,333	1,056	63	1,119
Okaloosa	1	207,905	138,040	5,622	415	6,037	0.300%	225,028	148,135	6,061	444	6,505
Santa Rosa	1	159,450	100,644	6,685	51	6,736	0.050%	178,786	114,807	7,632	57	7,689
Walton	1	65,701	44,521	2,035	56	2,091	0.125%	77,165	58,487	2,819	73	2,892
Washington	1	26,129	12,074	1,476	100	1,576	0.825%	27,640	12,634	1,546	104	1,650
Calhoun	2	14,770	7,723	1,060	100	1,160	1.300%	15,560	7,678	1,054	100	1,154
Franklin	2	12,446	13,171	413	263	676	2.000%	13,078	13,416	417	268	685
Gadsden	2	50,324	17,129	2,437	462	2,899	2.700%	52,179	17,929	2,550	484	3,034
Gulf	2	17,317	11,879	506	214	720	1.800%	18,183	12,861	548	231	779
Jackson	2	54,054	13,575	1,122	95	1,217	0.700%	56,204	14,154	1,170	99	1,269
Jefferson	2	14,932	3,921	283	137	420	3.500%	15,558	3,864	279	135	414
leon	2	291,676	71,263	2,713	1,425	4,138	2.000%	313,127	74,261	2,827	1,485	4,312
Liberty	2	8,203	2,174	214	130	344	6.000%	8,635	2,174	214	130	344
Wakulla	2	34,098	34,889	943	698	1,641	2.000%	38,372	39,189	1,059	784	1,843
Alachua	3	259,838	91,736	13,137	459	13,596	0.500%	277,311	97,715	13,987	489	14,476
Bradford	3	29,776	14,594	1,282	194	1,476	1.330%	31,171	15,010	1,313	200	1,513
Columbia	3	68,838	36,131	3,844	426	4,270	1.180%	74,230	37,747	3,954	445	4,399
Dixie	3	16,935	14,823	1,502	148	1,650	1.000%	18,377	15,953	1,570	160	1,730
Gilchrist	3	18,555	10,287	936	70	1,006	0.680%	20,709	10,795	976	73	1,049
Hamilton	3	14,961	8,164	921	82	1,003	1.000%	15,475	8,310	936	83	1,019
Lafayette	3	8,440	4,136	560	14	574	0.330%	8,863	4,287	578	14	592
Madison	3	20,525	11,045	1,239	75	1,314	0.680%	21,304	11,286	1,259	77	1,336
Suwannee	3	43,547	23,518	2,852	78	2,930	0.330%	47,383	24,495	2,936	81	3,017
Taylor	3	22,410	16,003	1,523	72	1,595	0.450%	23,436	16,527	1,556	74	1,630
Union	3	16,207	8,937	951	61	1,012	0.680%	17,032	9,186	981	62	1,043
Baker	4	26,904	14,921	2,698	75	2,773	0.500%	28,989	15,367	2,696	77	2,773
Clay	4	201,131	110,999	9,039	444	9,483	0.400%	229,352	125,908	10,235	504	10,739

Duval	4	944,488	626,394	50,878	4,385	55,263	0.700%	1,017,730	672,247	57,112	4,706	61,818
Flagler	4	113,148	70,734	6,493	354	6,847	0.500%	141,278	87,388	7,973	437	8,410
Nassau	4	75,805	61,355	4,018	185	4,203	0.300%	84,533	67,874	4,288	204	4,492
Putnam	4	76,982	51,224	6,695	6	6,701	0.010%	79,946	52,523	6,857	5	6,862
St.Johns	4	193,431	169,881	9,502	510	10,012	0.300%	226,067	197,007	10,690	591	11,281
Citrus	5	149,275	92,073	12,467	56	12,523	0.450%	163,490	100,718	13,654	62	13,716
Hernando	5	173,986	114,399	11,283	43	11,326	0.380%	193,826	127,346	12,560	48	12,608
Levy	5	42,545	33,560	4,308	19	4,327	0.450%	46,629	36,740	4,719	21	4,740
Marion	5	353,683	176,142	21,235	107	21,342	0.500%	397,954	195,131	23,534	118	23,652
Sumter	5	99,654	55,045	12,606	42	12,648	0.330%	119,602	65,162	14,777	49	14,826
Brevard	6	586,060	483,336	32,586	98	32,684	0.300%	635,195	527,360	35,937	108	36,045
Lake	6	319,321	167,563	25,231	384	25,615	1.500%	368,493	197,833	29,446	448	29,894
Orange	6	1,204,474	318,704	26,320	220	26,540	0.830%	1,347,777	353,642	29,081	243	29,324
Osceola	6	309,202	86,339	7,309	37	7,346	0.500%	371,210	109,889	8,495	43	8,538
Seminole	6	458,006	120,692	10,332	19	10,351	0.180%	500,327	127,944	10,888	20	10,908
Volusia	6	543,988	440,991	38,008	241	38,249	0.630%	589,118	469,471	53,542	339	53,881
DeSoto	7	35,707	21,156	3,159	571	3,730	2.700%	39,870.00	23,446	3,457	633	4,090
Hardee	7	28,389	14,217	2,167	284	2,451	2.000%	29,691.00	16,019	2,444	320	2,764
Highlands	7	103,735	37,567	8,104	262	8,366	0.700%	111,992.00	40,589	8,553	284	8,837
Okeechobee	7	40,300	38,520	5,295	1,271	6,566	3.300%	42,269.00	42,353	5,752	1,398	7,150
Polk	7	617,492	179,915	26,570	2,338	28,908	1.300%	676,957.00	193,773	28,502	2,519	31,021
Hillsborough	8	1,272,270	643,792	47,195	2,446	49,641	0.380%	1,394,643	697,462	50,797	2,650	53,447
Manatee	8	338,254	313,285	19,441	2,193	21,634	0.700%	372,269	349,537	17,942	2,447	20,389
Pasco	8	474,600	312,273	25,327	2,810	28,137	0.880%	533,601	326,354	26,597	2,872	29,469
Pinellas	8	968,631	708,156	42,370	7,436	49,806	1.050%	992,680	729,413	43,229	7,659	50,888
Charlotte	9	175,389	180,275	11,474	1,352	12,826	0.750%	192,753	197,497	11,765	1,481	13,246
Collier	9	379,226	329,479	25,568	1,812	27,380	0.550%	440,142	362,702	22,286	1,995	24,281
Glades	9	11,613	8,644	1,392	16	1,408	0.180%	12,127	9,330	1,530	17	1,547
Hendry	9	41,410	27,116	3,721	225	3,946	0.830%	44,597	29,570	4,097	245	4,342
Lee	9	676,531	626,078	32,216	2,379	34,595	0.380%	782,593	687,293	40,245	2,612	42,857
Sarasota	9	412,970	349,525	28,209	3,076	31,285	0.880%	451,354	389,878	32,738	3,431	36,169
Indian River	10	149,972	78,149	3,524	1,954	5,478	2.500%	166,767	83,119	3,727	2,078	5,805
Martin	10	154,050	85,665	4,246	1,885	6,131	2.200%	166,989	90,244	4,479	1,985	6,464
Palm Beach	10	1,404,907	444,686	28,467	5,336	33,803	1.200%	1,538,798	480,110	30,743	5,761	36,504
St. Lucie	10	298,841	96,935	5,982	2,423	8,405	2.500%	346,212	108,370	6,656	2,709	9,365
Broward	11	1,869,913	638,542	25,907	1,277	27,184	0.200%	2,005,703	675,370	26,987	1,351	28,338
Miami-Dade	11	2,568,807	905,557	59,177	2,717	61,894	0.300%	2,720,247	965,798	61,350	2,897	64,247
Monroe	11	80,663	72,868	2,771	91	2,862	0.123%	80,844	77,142	2,932	95	3,027
Total:		19,979,199	10,313,991	777,109	57,910	835,019		21,831,514	11,189,254	852,770	62,361	915,131
2010 Census		18,801,310	The 2010 and 2015 population projections from the 2010 Statewide Regional Evacuation Studies were used for the 2012 and 2017 projections above.									

**Appendix K:**  
**Guidance for Selection of Impact Resistant Constructed Wall and Roof Assemblies**

## **Appendix K – Guidance for Selection of Impact Resistant Constructed Wall and Roof Assemblies**

### **K.0 STRUCTURAL MISSILE IMPACT CRITERIA**

The public shelter design criteria, which are also known as the EHPA criteria, require that exterior walls and roofs prevent perforation or penetration by windborne debris. Laboratory testing is the primary means of determining if a specific assembly (i.e., exterior and interior surface cladding, structural components and configurations, material properties, connections, etc.) is capable of satisfying the applicable performance criteria. Certain types of commonly used non-proprietary materials and constructed assemblies have been demonstrated through laboratory testing to satisfy the required debris impact performance criteria. Constructed assemblies that are approved for use without further testing by the authority having jurisdiction are commonly referred to as “deemed to comply.” The deemed to comply method is recognized in section 1626.4, *Florida Building Code—Building*. Appendix K has been prepared to assist designers with selection of constructed wall and roof assemblies that have been tested and satisfy applicable large missile impact criteria.

Please note that the Department of Education has stated that roof assemblies must be tested and certified to meet ASTM E-1886 and ASTM E-1996 or SSTD 12 as an assembly. This applies to district school board and community college facilities. With the exception of code prescribed concrete deck assemblies, “deemed to comply” assemblies will not be approved by the Department of Education. Therefore, “deemed to comply” assemblies are only applicable to other state and local agency facilities.

The Florida Department of Education’s list of approved roof decks can be found at the following web address (Publications, Roof Decks on Public Hurricane Shelters):

<http://www.fldoe.org/edfacil/formsplanreview.asp>

### **K.1 METHODOLOGY**

To begin the assembly selection process, it is critical to determine the design wind velocity of the EHPA. Higher design wind speeds (and their associated windfield) impart higher velocities to entrained debris. Higher wind velocities can also lift and accelerate larger and heavier debris objects, as well as extend the distance downwind that an object can travel. As a planning guide, unanchored, inadequately anchored or poorly constructed large debris can be generated from sources within a distance of about 300 feet of proposed or constructed EHPA(s). Smaller debris down to the size of gravel can be generated from sources out to a range of possibly 1,500 feet. Research considered by the ICC storm shelter standard committee indicates that objects lifted by wind forces undergo rapid acceleration and achieve velocities of between 40 and 80 percent of the entraining wind field’s velocity. Thus the lower bound for representative missiles requires large missile test velocities of at least 40 percent of the proposed design wind speed.

The industry-recognized straight wind (which include hurricane) large missile that is used for impact testing is a nine pound sawn lumber 2x4 (9 lb 2x4). The industry-recognized 9 lb 2x4 large missile is also the missile required to satisfy the EHPA code provisions. For those school districts that are interested in incorporating tornado protection into an EHPA construction project, national guidance currently recommends that the large missile be increased to a 15 pound sawn lumber 2x4 (15 lb 2x4). In addition to tornado applications, the Division also recommends increasing the large missile requirement to a 15 lb 2x4 for EHPA's that may be subjected to an unusual barrage of heavy debris (e.g., building materials and mechanical equipment).

Debris impact testing of wall and roof assemblies has generally been conducted using a limited number of specified conditions (e.g., 9 and 15 lb 2x4s propelled at 34, 50 or 55, 75 and 100 miles per hour). Many of the more robust materials and assemblies, such as reinforced concrete and solid-grouted masonry, have satisfied test requirements that are significantly more demanding than the EHPA code's minimum-large missile requirement of ASTM E-1996 or SSTD 12. Another factor considered by the Division is that current research indicates that an object's impact momentum, and not energy, provides the best correlation of test performance of a specified assembly when comparing missiles of different weights and velocities. Calculating the momentum associated with a published sample's impact test conditions permits the data to be converted to the industry standard straight wind 9 lb 2x4 missile. Impact momentum is calculated as follows: missile mass [weight (lb) / acceleration of gravity (32.2 ft/sec<sup>2</sup>)] x missile velocity (ft/sec) = momentum (lb-sec); or:

$$\text{Momentum} = (W/g) \times v$$

It should be noted that in addition to momentum values, Tables K-1 and K-2 provide corresponding impact energy values to assist with conversion when momentum is not calculated but impact energy of a test is shown.

The following reference data sources were used to compile the list of assemblies given in Table K-3. Windborne Debris Impact Resistant Wall Assemblies, and Table K-4. Windborne Debris Impact Resistant Roof Assemblies:

1. *Large Wind Missile Impact Performance of Public and Commercial Building Assemblies*, Florida Agricultural and Mechanical University-Florida State University (FAMU-FSU) in cooperation with the University of Florida (UF), 2004
2. *Summary Report on Debris Impact Testing at Texas Tech University*, Texas Tech University (TTU), 2003
3. *Design and Construction Guidance for Community Shelters* (FEMA 361), Federal Emergency Management Agency, 2000

These reference sources can provide additional guidance on selection of suitable wall and roof assemblies for both hurricane and tornado shelters.

To match the existing data sources' test conditions with a practical range of corresponding design wind speeds, the Division consolidated the data into categories defined as "Levels of Protection." The test performance required to satisfy each level of protection is bounded by the respective level's highest hurricane design wind speed. As an example, Enhanced-B's design wind speed range is 161 to 190 miles per hour (mph), therefore the assembly must satisfy a laboratory missile test equal to a 9 lb 2x4 propelled at 75 mph ( $190 \times 0.40 = 75$ ).

The lowest level of protection, which is referred to by the Division as "Basic-D," is equal to the large missile test requirements of SSTD 12 and ASTM E 1996 Missile Level D (i.e., 9 lb 2x4 propelled at 34 mph). Basic-D is the minimum code requirement for EHPA walls and roofs. ASTM E 1996 also establishes a nominally higher large missile test missile defined as Level E, which increases the test velocity of the 9 lb 2x4 to 55 mph. For the purposes of this appendix, ASTM E 1996's Missile Level E is referred to as "Basic-E" as its performance is insufficient for ICC hurricane shelter standards. The reference sources used by the Division for preparation of this appendix do not provide test data specific to ASTM E 1996's Missile Level E.

The Division's Enhanced-A level of protection corresponds to design wind speeds of 141 to 159 mph (3-second gust). The Enhanced-A missile criteria is equal to a 9 lb 2x4 propelled at 65 mph. The 141 to 159 mph design wind speed range is also consistent with a Saffir-Simpson Scale hurricane Category 3 (i.e., 135 mph to 159 mph, 3-second gust).

The Division's Enhanced-B level of protection corresponds to design wind speeds of 160 to 189 mph (3-second gust). The Enhanced-B missile criteria is equal to a 9 lb 2x4 propelled at 75 mph. Conveniently, the 9 lb 2x4 propelled at 75 mph test missile has approximately the same impact momentum as the Department of Energy's recommended straight wind missile criteria, which is a 15 lb 2x4 propelled at 50 mph (15 lb 2x4 @ 50 mph). The 15 lb 2x4 @ 50 mph is a relatively common enhanced performance test so there are several wall and roof assemblies that have been demonstrated to satisfy its performance criteria. The 160 to 189 mph design wind speed range is also consistent with a Saffir-Simpson hurricane Category 4 (i.e., 160 mph to 189 mph, 3-second gust).

The Enhanced-C level of protection exceeds the EHPA's minimum design wind speed range, and includes hurricane design wind speeds of 190 to 225 mph. Design wind speeds in this range are consistent with a Saffir-Simpson Scale hurricane Category 5. Enhanced-E levels of protection are consistent with tornado missile test criteria established in ICC 500, FEMA 361 and other national guidance publications for EF4 and EF5 tornadoes.

It should be noted that Tables K-1 and K-3 provide criteria for exterior envelope vertical surfaces, such as walls. Exterior envelope surfaces that are inclined less than 30 degrees from horizontal are considered horizontal surfaces and Tables K-2 and K-4 apply. For the purposes of this appendix, the missile velocity requirement for horizontal surfaces is assumed to be 67 percent of that required for the respective vertical surface.

This is consistent with tornado missile test criteria found in ICC 500, FEMA 361 and other national guidance publications. This is conservative since hurricane missile requirements for horizontal surfaces may only be 25 percent of that required for vertical surfaces, but negligible data is available for such low impact criteria. Also, weak to moderate tornadoes and other isolated wind disturbances can be embedded in hurricanes, which can cause severe local impacts. Therefore, the use of the tornado missile percent of design wind velocity for horizontal surfaces of hurricane shelters is not exceptionally conservative.

## **K.2 SELECTION OF WALL OR ROOF ASSEMBLIES**

With the type of wind event (straight or tornado wind) and design wind speed established, the designer or specifying authority can select an appropriate windborne debris impact level of protection that best suits performance expectations. The levels of protection categories simplify the selection of appropriate wall and roof assemblies to match the EHPA's design wind speed. As an example, for an EHPA with a hurricane design wind speed of 170 mph the representative missile's lower bound velocity is equal to 40 percent of the design wind speed, or 68 mph ( $170 \times 0.40 = 68$ ). Instead of searching for test results specific to a 9 lb 2x4 propelled at 68 mph (9 lb 2x4 @ 68 mph), the designer or specifying authority can select the level of protection applicable to 170 mph from Table K-1 (for vertical surfaces), which is an "Enhanced-B" level of protection; i.e., design wind speed between 160 and 189 mph. The Enhanced-B determination will also concurrently apply to the building's horizontal surfaces, such as roofs (i.e., 9 lb 2x4 @ 50 mph)

With the level of protection determined for both vertical and horizontal surfaces, the designer or specifying authority then selects a wall and roof assembly from Tables K-3 and K-4, respectively, that satisfies the minimum impact momentum resistance criteria. Tables K-3 and K-4 provide the following information:

Column 1 (left-most column) – A wall/roof number for reference purposes

Column 2 – Assembly Type, such as wood, metal, CMU/masonry, reinforced concrete, etc; light wood and metal stud framing is included under wood assembly type, and brick masonry over sheathing material and light wood or metal framing is also included under wood assembly type

Column 3 – Assembly description, which includes inside and outside sheathing materials (if any) and nominal dimensions, reinforcement and connections as applicable

Column 4 – Data source, which can be used as reference for additional information; the data sources are:

1. *Large Wind Missile Impact Performance of Public and Commercial Building Assemblies*, Florida Agricultural and Mechanical University-

Florida State University (FAMU-FSU) in cooperation with the University of Florida (UF), 2004

2. *Summary Report on Debris Impact Testing at Texas Tech University*, Texas Tech University (TTU), 2003
3. *Design and Construction Guidance for Community Shelters* (FEMA 361), Federal Emergency Management Agency, 2000

Column 5 – Level of Protection, which is subdivided into Basic-D (9 lb 2x4 @ 34 mph) and Enhanced-A (9 lb 2x4 @ 65 mph) through Enhanced-D (9 lb 2x4 @ 100 mph); Column 5 also lists the respective impact momentum associated with each level of protection

Under the listed levels of protection in Column 5, the specified test performance results are given as “Satisfied the Test Criteria” (S); “Failed the Test Criteria” (F); or “No Data/Not Determined” (ND). For assemblies that fail at a given level of protection, the higher performance requirements are listed as “---.”

All dimensions are subject to conventional industry tolerances unless noted otherwise. The order of materials given in each assembly description is listed from the outside/outer most surface material (opposite the occupied shelter space), then inwards toward the inside finish surface material (if any). The missile impact is assumed to be on the outside surface. The order of installation is important, since some of the assemblies rely on flexure to resist (or absorb) the impact forces (e.g., for Wall No. 7, the 14 ga. expanded steel sheeting must be located between the double 2x4 wood stud supports on the inside of the assembly, and the two layers of 3/4 inch plywood located at the outer most surface).

Tables K-3 and K-4 provide nominal reinforcement and connection information. The building designer of record is responsible for determining all design loads and specifying all structural elements and connections in accordance with applicable material design standards, codes, rules, regulations and manufacturer’s instructions. The Division strongly recommends that design wind pressures for components and cladding be calculated with wind exposure category = C.

Note that there is insufficient data available to establish a stand-alone Basic-E level of protection category. Therefore, in the absence of specific tests performed to satisfy Basic-E, the Division recommends use of the Enhanced-A level of protection category for design wind speeds that are less than 140 mph.



<b>Table K-1. Windborne Debris Impact Criteria Comparisons for Vertical Surfaces</b>						
Level of Protection, Vertical Surface	Hurricane Design Wind Speed, mph (3-sec. gust)	Missile Weight, lbs	Missile Velocity, mph	Missile Velocity, ft/sec	Energy, ft-lb	Momentum, lb-sec
Basic-D	85 or less	9	34	50	349	14
Basic-E	86-140	9	50	74	765	21
Basic-E	86-140	9	55	80	894	22
Enhanced-A	141-159	9	60	88	1,082	25
<b>Enhanced-A*</b>	<b>141-159</b>	<b>9</b>	<b>65</b>	<b>95</b>	<b>1,261</b>	<b>27</b>
Enhanced-B	160-189	9	70	103	1,483	29
<b>Enhanced-B*</b>	<b>160-189</b>	<b>9</b>	<b>75</b>	<b>110</b>	<b>1,691</b>	<b>31</b>
Enhanced-C	190-225	9	80	117	1,913	33
Enhanced-C	190-225	9	85	125	2,184	35
<b>Enhanced-C*</b>	<b>190-225</b>	<b>9</b>	<b>90</b>	<b>132</b>	<b>2,435</b>	<b>37</b>
Enhanced-D	226-255	9	95	139	2,700	39
<b>Enhanced-D*</b>	<b>226-255</b>	<b>9</b>	<b>100</b>	<b>147</b>	<b>3,020</b>	<b>41</b>
Enhanced-C	190-225	15	50	74	1,275	34
Enhanced-C	190-225	15	55	80	1,491	37
Enhanced-D	226-255	15	60	88	1,804	41
Enhanced-E	EF3 Tornado	15	85	125	3,639	58
<b>Enhanced-E*</b>	<b>EF4 &amp; 5 Tornado</b>	<b>15</b>	<b>100</b>	<b>147</b>	<b>5,033</b>	<b>68</b>

\*-Denotes missile impact criteria (weight and velocity) selected to represent the specified level of protection.

<b>Table K-2. Windborne Debris Impact Criteria Comparisons for Horizontal Surfaces</b>						
Level of Protection, Horizontal Surface**	Hurricane Design Wind Speed, mph (3-sec. gust)	Missile Weight, lbs	Missile Velocity, mph	Missile Velocity, ft/sec	Energy, ft-lb	Momentum, lb-sec
Basic-D***	85 or less	9	23	34	162	10
Basic-E***	86-140	9	33	48	322	13
Basic-E***	86-140	9	37	54	408	15
Enhanced-A	141-159	9	40	57	454	16
<b>Enhanced-A*</b>	<b>141-159</b>	<b>9</b>	<b>44</b>	<b>65</b>	<b>590</b>	<b>18</b>
Enhanced-B	160-189	9	47	69	665	19
<b>Enhanced-B*</b>	<b>160-189</b>	<b>9</b>	<b>50</b>	<b>74</b>	<b>765</b>	<b>21</b>
Enhanced-C	190-225	9	54	79	872	22
Enhanced-C	190-225	9	57	84	986	23
<b>Enhanced-C*</b>	<b>190-225</b>	<b>9</b>	<b>60</b>	<b>88</b>	<b>1,082</b>	<b>25</b>
Enhanced-D	226-255	9	64	94	1,235	26
<b>Enhanced-D*</b>	<b>226-255</b>	<b>9</b>	<b>67</b>	<b>98</b>	<b>1,342</b>	<b>27</b>
Enhanced-C	190-225	15	33	48	537	22
Enhanced-C	190-225	15	37	54	679	25
Enhanced-D	226-255	15	40	57	757	27
Enhanced-E	EF3 Tornado	15	57	84	1,643	39
<b>Enhanced-E*</b>	<b>EF4 &amp; 5 Tornado</b>	<b>15</b>	<b>67</b>	<b>98</b>	<b>2,237</b>	<b>46</b>

\*-Denotes missile impact criteria (weight and velocity) selected to represent the specified level of protection.  
\*\*-Horizontal surface impact loading velocity is based on tornado factor of 0.67 of vertical surface velocity.  
\*\*\*-SSTD 12, ASTM E 1886 and E 1996 and the structural requirements of Section 423.25.4, FBC do not permit a reduction in basic missile test velocity due to an assembly's horizontal surface orientation.

<b>Table K-3. Windborne Debris Impact Resistant Wall Assemblies</b>								
<b>Wall No.</b>	<b>Assembly Type</b>	<b>Assembly Description</b>	<b>Data Source</b>	<b>Level of Protection</b>				
				<b>Basic D</b>	<b>Enhanced A</b>	<b>Enhanced B</b>	<b>Enhanced C</b>	<b>Enhanced D</b>
				Minimum Required Impact Test Momentum, lb-sec				
				14	27	31	37	41
1	Wood	One layer 1/2 inch CD grade plywood on metal or 2"x4" wood studs	1	F	---	---	---	---
2	Wood	Stucco veneer on one layer 1/2 inch CD grade plywood, OSB, GWB or rigid insulation on metal or 2"x4" wood studs	1	F	---	---	---	---
3	Wood	One layer 3/4 inch CD grade plywood on double 2"x4" wood studs (4"x4")	2	S	F	---	---	---
4	Wood	Two layers 3/4 inch CD grade plywood on double 2"x4" wood studs (4"x4")	2	S	S	F	---	---
5	Wood	One layer 1/2 inch CD grade plywood with masonite siding on 2"x4" wood studs	2	ND	ND	F	---	---
6	Wood	One layer 1/2 inch CD grade plywood with 5/16 inch hardiboard siding, metal or 2"x4" wood studs	1	F	---	---	---	---

<b>Table K-3. Windborne Debris Impact Resistant Wall Assemblies</b>								
<b>Wall No.</b>	<b>Assembly Type</b>	<b>Assembly Description</b>	<b>Data Source</b>	<b>Level of Protection</b>				
				<b>Basic D</b>	<b>Enhanced A</b>	<b>Enhanced B</b>	<b>Enhanced C</b>	<b>Enhanced D</b>
				<b>Minimum Required Impact Test Momentum, lb-sec</b>				
				14	27	31	37	41
7	Wood	Two layers 3/4 inch CD grade plywood, 14 ga. sheet steel liner and double 2"x4" wood studs (4"x4")	2	S	S	S	S	S
8	Wood	4 inch brick veneer, 1/2 inch CD grade plywood sheathing and 2"x4" wood studs at 24 in oc	1	S	S	F	---	---
9	Wood	4 inch brick veneer, 7/16 inch OSB sheathing on 2"x4" wood studs at 24 in oc	1	S	S	F	---	---
10	Wood	24 ga. or 26 ga. galv. metal siding on 1/2 inch CD grade plywood and 2"x4" wood stud	1	S	F	---	---	---
11	Wood	24 ga. or 26 ga. galv. metal siding on 7/16 inch OSB and 2"x4" wood stud	1	S	F	---	---	---
12	Metal	24 ga. or 26 ga. (50 ksi) galv. metal panels on Z 8.25, 14 ga. girts @ 5 feet oc	1	S	ND	ND	ND	ND
13	Metal	24 ga. (50 ksi) galv. metal panels on Z 8.0, 16 ga. girts @ 3 feet oc	1	S	S	S	ND	ND
14	Metal	24 ga. (80 ksi) galv. metal panels on Z 8.0, 16 ga. girts @ 3 feet oc	1	S	S	S	ND	ND

<b>Table K-3. Windborne Debris Impact Resistant Wall Assemblies</b>								
<b>Wall No.</b>	<b>Assembly Type</b>	<b>Assembly Description</b>	<b>Data Source</b>	<b>Level of Protection</b>				
				<b>Basic D</b>	<b>Enhanced A</b>	<b>Enhanced B</b>	<b>Enhanced C</b>	<b>Enhanced D</b>
				<b>Minimum Required Impact Test Momentum, lb-sec</b>				
				14	27	31	37	41
15	Metal	20 ga. or 22 ga. (50 ksi) metal panels on Z 8.25, 16 ga. girts @ 3 feet oc	1	S	S	S	ND	ND
16	CMU	8, 10 and 12 inch hollow cell CMU with #4 or larger rebar vertical reinforcement in grout filled cells as required for wind design; truss-type horizontal reinforcement in joints @ 16 inches oc	1,2	S	F	---	---	---
17	CMU	8 inch structural pea-gravel grout filled CMU reinforced with #4 or larger rebar as required for wind design; truss-type horizontal reinforcement in joints @ 16 inches oc	2	S	S	S	S	ND
18	CMU	4 inch brick veneer with 8, 10 or 12 inch hollow cell CMU back-up reinforced with #4 or larger rebar as required for wind design; truss-type horizontal reinforcement in joints @ 16 inches oc	1	S	S	ND	ND	ND

<b>Table K-3. Windborne Debris Impact Resistant Wall Assemblies</b>								
<b>Wall No.</b>	<b>Assembly Type</b>	<b>Assembly Description</b>	<b>Data Source</b>	<b>Level of Protection</b>				
				<b>Basic D</b>	<b>Enhanced A</b>	<b>Enhanced B</b>	<b>Enhanced C</b>	<b>Enhanced D</b>
				<b>Minimum Required Impact Test Momentum, lb-sec</b>				
				14	27	31	37	41
19	CMU	6 inch structural pea-gravel grout filled CMU reinforced with #4 or larger rebar in every cell; truss-type horizontal reinforcement in joints @ 16 inches oc	2,3	S	S	S	S	S
20	CMU	8, 10 or 12 inch structural pea-gravel grout filled CMU reinforced with #4 or larger rebar in every cell; truss-type horizontal reinforcement in joints @ 16 inches oc	2,3	S	S	S	S	S
21	RC	2 inch pea-gravel concrete with #4 rebar at 12 inches oc each way	2	S	F	---	---	---
22	RC	3 inch pea-gravel concrete with #4 rebar at 12 inches oc each way	2	S	S	S	S	S
23	RC	4 inch to 6 inch pea-gravel concrete reinforced with #4 rebar at 12 inches oc each way	2	S	S	S	S	S
24	RC	5 inch pea-gravel concrete tilt-up wall panel reinforced with #5 rebar at 12 inches oc longitudinal and #3 rebar at 12 inches oc temperature reinforcement	1	S	S	ND	ND	ND

<b>Table K-3. Windborne Debris Impact Resistant Wall Assemblies</b>								
<b>Wall No.</b>	<b>Assembly Type</b>	<b>Assembly Description</b>	<b>Data Source</b>	<b>Level of Protection</b>				
				<b>Basic D</b>	<b>Enhanced A</b>	<b>Enhanced B</b>	<b>Enhanced C</b>	<b>Enhanced D</b>
				<b>Minimum Required Impact Test Momentum, lb-sec</b>				
				14	27	31	37	41
25	RC	6 inch pea-gravel concrete panel reinforced with #4 rebar at 12 inches oc each way	2,3	S	S	S	S	S
26	RC	6 inch pea-gravel concrete panel reinforced with #4 rebar at 24 inches oc each way	2	S	S	S	S	S
27	RC	8 inch to 10 inch pea-gravel concrete reinforced with #4 rebar at 12 inches oc each way, placed 1-1/2 inches from each face	2	S	S	S	S	S
28	RC	11 inch brick cavity masonry wall with cavity filled with pea-gravel concrete and reinforced with #4 rebar at 12 inches oc each way	2	S	S	S	S	S
29	ICF	6 inch (or thicker) ICF wall panels with concrete at least 4 inches thick and reinforced with #4 rebar at 12 inches oc each way	1,2	S	S	S	S	ND
30	ICF	6 inch (or thicker) ICF waffle-grid wall section reinforced with #5 rebar every 12 inches vertically and #4 rebar every 16 inches horizontally	1,2	S	S	S	S	ND

<b>Table K-3. Windborne Debris Impact Resistant Wall Assemblies</b>								
<b>Wall No.</b>	<b>Assembly Type</b>	<b>Assembly Description</b>	<b>Data Source</b>	<b>Level of Protection</b>				
				<b>Basic D</b>	<b>Enhanced A</b>	<b>Enhanced B</b>	<b>Enhanced C</b>	<b>Enhanced D</b>
				<b>Minimum Required Impact Test Momentum, lb-sec</b>				
				14	27	31	37	41
31	AAC	8x8x24 Autoclaved Aerated Concrete wall panel	1	S	F	---	---	---
S = Satisfied the Test Criteria F = Failed the Test Criteria ND = No Data/Not Determined								



<b>Table K-4. Windborne Debris Impact Resistant Roof Assemblies</b>								
<b>Roof No.</b>	<b>Assembly Type</b>	<b>Assembly Description</b>	<b>Data Source</b>	<b>Level of Protection</b>				
				<b>Basic D</b>	<b>Enhanced A</b>	<b>Enhanced B</b>	<b>Enhanced C</b>	<b>Enhanced D</b>
				Minimum Required Impact Momentum Resistance, lb-sec				
				10	18	22	27	39
1	Wood	One layer 1/2 inch CD grade plywood or 7/16 inch OSB on metal or wood joist or truss with wood, clay or asphalt shingle roof cover	1	F	---	---	---	---
2	Wood	One layer 19/32 inch or thicker CD grade plywood on metal or wood joist or truss with wood, clay or asphalt shingle roof cover	1	S	F	---	---	---
3	Wood	24 ga. or 26 ga. galv. metal roof cover on 1/2 inch or thicker CD grade plywood on metal or wood joist or truss	1	S	ND	ND	ND	F
4	Metal	24 ga. or 26 ga. (50 ksi) galv. metal panels on 16 ga. purlins @ 2 feet oc	1	S	S	S	ND	ND
5	Metal	20 ga. or 22 ga. (50 ksi) metal panels on Z 8.25, 16 ga. purlins @ 2 feet oc	1	S	S	S	ND	ND
6	Metal	1-1/2 inch 20 ga. or 22 ga. Type B, Grade 33 structural metal deck over Z 8.25 girt supports @ 5 feet oc with 26 ga. galv. metal roof cover	1	S	S	S	S	S

<b>Table K-4. Windborne Debris Impact Resistant Roof Assemblies</b>								
<b>Roof No.</b>	<b>Assembly Type</b>	<b>Assembly Description</b>	<b>Data Source</b>	<b>Level of Protection</b>				
				<b>Basic D</b>	<b>Enhanced A</b>	<b>Enhanced B</b>	<b>Enhanced C</b>	<b>Enhanced D</b>
				<b>Minimum Required Impact Momentum Resistance, lb-sec</b>				
				10	18	22	27	39
7	Metal	1-1/2 inch 20 ga. or 22 ga. Type B, Grade 33 structural metal deck over supports @ 4 feet oc with 26 ga. galv. metal roof cover	1	S	S	S	S	S
8	Metal	3 inch 22 ga. structural metal deck	1	S	S	S	S	F
9	RC	CIP 2 inch pea-gravel concrete with #4 rebar at 12 inches oc each way	2	S	S	F	---	---
10	RC	CIP 3 inch pea-gravel concrete with #4 rebar at 12 inches oc each way	2	S	S	S	S	S
11	RC	CIP 4 inch to 6 inch pea-gravel concrete reinforced with #4 rebar at 12 inches oc each way	2	S	S	S	S	S
12	RC	CIP 8 inch to 10 inch pea-gravel concrete reinforced with #4 rebar at 12 inches oc each way, placed 1-1/2 inches from each face	2	S	S	S	S	S
13	RC	4 inch or thicker concrete panel reinforced with #4 rebar at 12 inches oc each way	1,2	S	S	ND	ND	ND
14	RC	Precast 6 inch reinforced concrete hollow core slab	1	S	S	S	S	ND

<b>Table K-4. Windborne Debris Impact Resistant Roof Assemblies</b>								
<b>Roof No.</b>	<b>Assembly Type</b>	<b>Assembly Description</b>	<b>Data Source</b>	<b>Level of Protection</b>				
				<b>Basic D</b>	<b>Enhanced A</b>	<b>Enhanced B</b>	<b>Enhanced C</b>	<b>Enhanced D</b>
				Minimum Required Impact Momentum Resistance, lb-sec				
				10	18	22	27	39
15	RC	Precast 8, 10 or 12 inch reinforced concrete hollow core slab	1	S	S	S	S	S
S = Satisfied the Test Criteria F = Failed the Test Criteria ND = No Data/Not Determined								

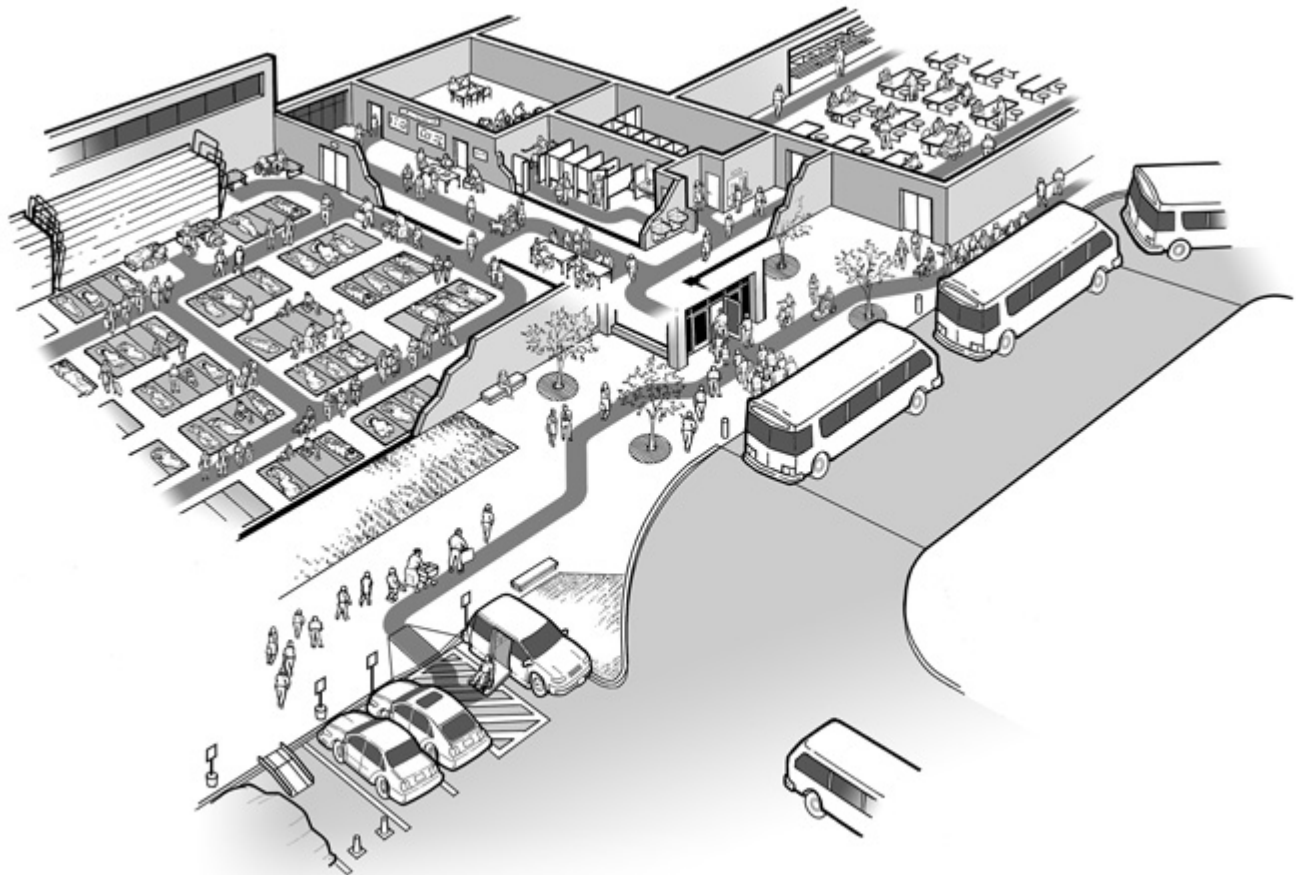
**Appendix L, Part 1:**

ADA Checklist for Emergency Shelters



## Americans with Disabilities Act/Florida Accessibility Code

# Checklist for Emergency Shelters



March 3, 2008

U.S. Department of Justice  
Civil Rights Division  
*Disability Rights Section*



*Corrected to reflect Florida code with permission*

## **Reproduction**

This document has been altered to include Florida specific requirements with permission from the U.S. Department of Justice.

Reproduction of this document is encouraged. An electronic copy x of this publication may be obtained by contacting the Statewide Disability Coordinator at 850-413-9892

## **Disclaimer**

The ADA authorizes the Department of Justice to provide technical assistance to individuals and entities that have rights or responsibilities under the Act. This document provides informal guidance to assist you in understanding the ADA and the Department's regulation. However, this technical assistance does not constitute a legal interpretation of the statute.

### **ADA Checklist for Emergency Shelters**

- A. Evaluating the Physical Accessibility of Emergency Shelters
- B. Conducting Accessibility Survey
- C. Getting Started
- D. Tools Needed
- E. Taking Measurements
  - 1. Sloped Surfaces
  - 2. Using the Tape Measure
  - 3. Measuring Door Openings
- F. Taking Photographs
- G. Completing the Survey and Checklist
- H. After Completing the Survey and Checklist

### **Step One: Accessible Shelter Quick-Check Survey**

Selecting Sites to Survey for Accessibility

- A. Accessible Entrance
- B. Accessible Routes To All Service/Activity Areas
- C. Accessibility within Toilet Rooms

### **Step Two: Ada Checklist For Emergency Shelters**

Getting to the Emergency Shelter

- A. Passenger Drop-Off Areas
- B. Parking
  - 1. Typical Issue

- 2. Parking Spaces Checklist
- 3. Temporary Solutions for Emergency Sheltering - Parking
- C. Sidewalks and Walkways
  - 1. Typical Issues for Individuals Who Use Wheelchairs, Scooters, or other Mobility Devices
    - Accessible Ramp Features
    - Temporary Solutions For Emergency Sheltering - Ramps
  - 2. Typical Issues for Individuals Who Are Blind or Have Low Vision
    - Temporary Solutions For Emergency Sheltering - Protruding Object Hazards
- D. Entering the Emergency Shelter
  - Building Entrance
- E. Hallways and Corridors
  - 1. Typical Issues for Individuals Who Use Wheelchairs, Scooters, or Other Mobility Devices
  - 2. Typical Issues for People Who are Blind or Have Low Vision
- F. Check-In Areas

### Living at the Emergency Shelter

- G. Sleeping Areas
- H. Restrooms and Showers
  - Toilet Stalls
- I. Public Telephones
- J. Drinking Fountains
- K. Eating Areas

### Other Issues

- L. Availability of Electrical Power
- M. Single-User or “Family” Toilet Room
- N. Health Units/Medical Care Areas
- O. Accessible Portable Toilets

## **Accessible Emergency Shelters**

One of the most important roles of State and local government is to protect people from harm, including helping people obtain food and shelter in major emergencies. When disasters occur, people are often provided safe refuge in temporary shelters located in schools, office buildings, tents, or other facilities.



Advance planning for an emergency shelter typically involves ensuring that the shelter will be well stocked with basic necessities, such as food, water, and blankets. Planning should also involve ensuring that these shelters are accessible to people with disabilities. Making emergency sheltering programs accessible is generally required by the Americans with Disabilities Act of 1990 (ADA).

### **A. Evaluating the Physical Accessibility of Emergency Shelters**

In order to be prepared for an emergency that requires sheltering, accessible features should be part of an emergency shelter. A first step to providing an accessible shelter is to identify any physical barriers that exist that will prevent access to people with disabilities. One good way to do this is to inspect each shelter facility that your community plans to use in an emergency and identify barriers to people with disabilities, including people who use wheelchairs or scooters or who have difficulty walking, people who are deaf or hard-of-hearing, and people who are blind or who have low vision. Facilities built or extensively altered since the ADA went into effect in 1992 (October 1, 1997 in Florida) may have few barriers to accessibility and could be good choices for emergency shelters. Facilities built before 1992 (1997 in Florida) and not altered to provide accessibility may have barriers that prevent access to people with disabilities.

When evaluating physical accessibility in older facilities, it may be a good idea to do the analysis in two parts. If you suspect that an older facility is not accessible, you can do a preliminary analysis before completing a detailed accessibility survey. This preliminary analysis, or quick-check, can eliminate facilities with extensive barriers so that the focus can be on those facilities that are most appropriate to become accessible shelters. To help identify older buildings that may be good candidates to become accessible shelters, a copy of the Accessible Shelter Quick-Check Survey is provided on page 7. After completing the Quick-Check Survey, if you have checked “Yes” for most of the questions on the forms, you should conduct a full accessibility survey using the ADA Checklist for Emergency Shelters.



If you find barriers to accessibility after completing the checklist, the next step is to either remove the barriers or identify other nearby accessible facilities that can serve as a shelter. In communities with more than one emergency shelter, until all shelters are accessible, the locations of accessible shelters should be widely publicized, particularly to people with disabilities and organizations that serve the disability community.

## **B. Conducting Accessibility Surveys**

The following Quick-Check Survey (beginning on page 7) and the ADA Checklist for Emergency Shelters (beginning on page 11) are designed to assist State and local officials and operators of emergency shelters to determine whether a facility being considered for use as an emergency shelter is accessible and if not, whether modifications are needed to remove barriers or whether relocation to another accessible facility is necessary. Filling out the Quick-Check Survey will provide guidance on whether a facility has certain basic accessible features, and filling out the detailed ADA Checklist for Emergency Shelters will provide specific information on any barriers to accessibility.

## **C. Getting Started**

Individuals conducting the surveys need not be experienced in evaluating facilities for accessibility. The checklist provides guidance on how to complete the survey and will prompt the user to check key elements. The checklist pages also provide space for notes and other key information. The checklist is designed to prompt the user to check key features by asking questions about sizes, sloped surfaces, and availability of accessible features; and in some areas, it suggests alternatives if a physical barrier is identified. By following the directions provided for filling out the checklist, staff can identify accessible shelters and develop information needed to implement temporary and permanent accessibility modifications.

An evaluation of shelter accessibility should focus on those areas of the facility that may be used for providing shelter in an emergency. These include areas where people are dropped off by a bus, van, or car; the parking area; the entrance to the shelter; pedestrian routes (both exterior and interior); sleeping, eating, information, and recreational areas; and toilet rooms.

Before shelter accessibility is evaluated, it is useful for staff to review the instructions for filling out the checklist and become familiar with the questions. It is also helpful to practice taking measurements, photographs, and recording information. On the day of the survey, it is helpful to first become familiar with certain areas before starting to record information. Upon arrival at the proposed shelter, first find the areas where people will disembark from vehicles, both passenger drop-off and loading zones as well as parking areas. Next find the entrances to the shelter areas that will be used during an evacuation. If possible, take an identifying “location” photograph that shows the name of the facility

and the address so that other photographs can be identified correctly. When inside the building, locate the areas where people are likely to register, sleep, and eat. Locate the toilet rooms that serve the shelter area. It is also a good idea to locate any areas used for telephones, food distribution, and medical services.

#### **D. Tools Needed**

The following items are needed for the survey:

- A metal tape measure that is at least 20 feet long;
- A digital level or bubble level that is 24 inches long;
- A door pressure gauge;
- A digital (preferred) or film camera with a flash;
- One copy of the checklist for each shelter (and Quick-Check Survey if used); and
- A clipboard and pens.

If you are not familiar with taking the types of measurements needed to complete the checklist, review the following section and practice using the tools before going to conduct a survey.

#### **E. Taking Measurements**

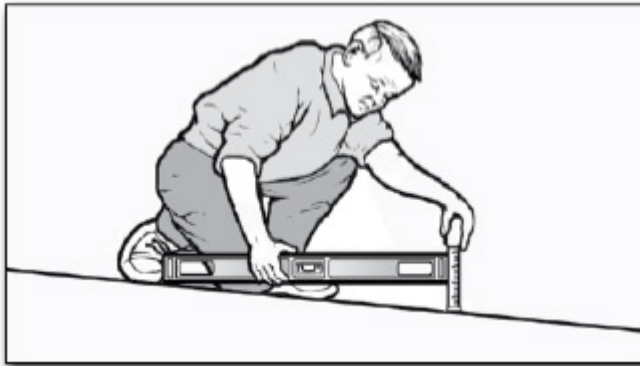
##### **1. Sloped Surfaces**

Measuring the slope of a ramp, parking space, walkway, or other ground or floor surface is important to identify whether the surface is accessible. The amount of slope or grade is described as the proportion of a vertical rise to a horizontal length. It is usually described as:

- a ratio (e.g., 1:20, which means one unit of vertical rise for each 20 units of horizontal length); or
- a percentage (e.g., 8.33% which equates to a ratio of 1:12 or 4.76 degrees).

The easiest way to measure slope is to use a digital level. The digital display gives a reading that may be shown as a percent, degrees, or as a digital bubble. Before using a digital level, make sure to understand the directions for its use. It will need to be calibrated before each use. The maximum running slope generally allowed for ramps is 1:12 (8.33% or 4.76 degrees). Cross slope is the slope or grade of a surface perpendicular to the running slope. The most cross slope allowed on an accessible route is 1:50 (2% or 1.15 degrees).

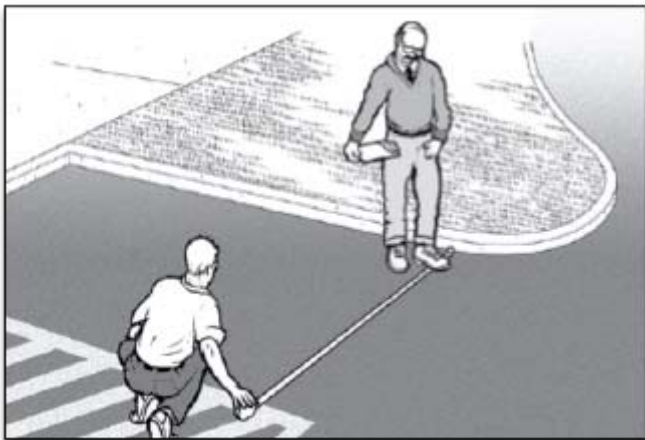
Another way to measure slope that requires more effort is to use a 24-inch level with leveling bubble and a metal tape measure. Place the level on the sloped surface in the direction you wish to measure. Rest one end of the level at the highest point of the sloped surface and lift the other end (see below) until the bubble is in the middle of the tube. This is the “level” position. While the level is in this position, measure the distance between the end of the level and the sloped surface below. If the distance is two inches or less, then the slope is 1:12 or less. When the distance is more than two inches, record the distance on the checklist so the exact slope can be calculated later. For measuring cross slope, if the distance, measured from the level position, is  $\frac{1}{2}$  inch or less then the slope is 1:48 or less.



**Measuring slope using a 24-inch bubble level and tape measure**

## **2. Using the Tape Measure**

A metal tape measure is needed to measure the length, width, height, and depth of various elements. When measuring long distances, pull the tape tight to get an accurate measurement. The checklist will offer guidance for the specific measurement that is required.



**Using a tape measure to measure the width of a parking space**

### 3. Measuring Door Openings

Special care is needed when measuring the clear opening of a doorway. To measure the clear opening of a standard hinged door, open the door to 90 degrees. Place the end of the tape measure on the side of the door frame next to the clear opening (see below). Stretch the tape across the door opening to the face of the door. This measures the clear width of the door opening through which people pass, which is less than the width of the door itself.



**Measuring the clear opening from the face of the doorstop on the frame to the face of the open door**

### F. Taking Photographs

A comprehensive set of photographs makes it easier to understand existing conditions after the survey is completed. It is a good idea to take many photos of the exterior and interior of the potential shelter. It is likely that many other people in your decision-making process will need to review information about the facility you are surveying, so try to record each element that you survey with several photos. It is always useful to first take a photo that will clearly identify the location of the element so that others will easily be able to find the element. Then, take several close-up shots of that element to document the conditions you found during your survey. If you are not familiar with the camera that you plan to use, practice using it both indoors and outdoors before starting to survey the various facilities being considered for use as shelters. If you are using a digital camera, it is a good idea to review the images as you take them to ensure that you have good quality photographs.

## **G. Completing the Survey and Checklist**

The survey and checklist forms will prompt you for what to look at and where to measure. You should write down all answers and notes for use later in the planning process. If a photo is taken of a particular element or condition, then you should note this on the checklist. It is usually more efficient for two or three people to work together doing these surveys. One person can measure while the other records the information and takes photos.

For each item, check either “Yes” or “No.” If the measurement or number falls short of that required for accessibility, write the measurement or number to the right of the question. Add notes or comments as needed. For some questions when “No” is the answer, the checklist will include a prompt to check for an alternate solution. Information on possible alternative solutions can be used later to decide how to better provide accessibility. Taking several photos is also helpful when the answer is “No” and an alternative way to provide accessibility is not readily apparent.

When completing the survey or checklist, try to answer every question in each section unless the element is not present at that facility. For example, if no parking lot is provided at the facility, (such as where only on-street parking is provided), do not measure the size of the on-street parking spaces.

Some sections of the checklist are divided into two parts, one for individuals with a mobility disability and the other for individuals who are blind or who have low vision. While evaluating a facility you will be checking to ensure that an accessible route is provided. The accessible route is a continuous unobstructed pedestrian path without steps or steep slopes that connects all accessible site and building features and spaces together. A continuous accessible route must be available at the shelter for people who use a wheelchair, scooter, or other mobility device. Other sections of the checklist ask questions related to individuals who are blind or have low vision. These questions cover all circulation paths, not just pedestrian paths that are also an accessible route.

The survey and the checklist are based on some of the requirements from the ADA Standards for Accessible Design (the Standards). Questions have been selected to reflect features that may be most important for the short-term stays common for emergency shelters. To learn more about the Standards, see the Department of Justice regulations, 28 C.F.R. Part 36, Appendix A. The regulations and the Standards are available at [www.ada.gov](http://www.ada.gov). Copies are also available by calling the ADA Information Line at 800-514-0301 (voice) or 800-514-0383 (TTY).

## **H. After Completing the Survey and Checklist**

Once you have completed the survey and filled out the checklist, you can determine which elements or spaces in a potential shelter facility are accessible and which may need modifications. If most answers are “yes,” the facility may need little or no modification. If some answers are “no,” modifications may be needed to remove barriers found in that space or element. Emergency shelters in older buildings with inaccessible features might be made accessible with temporary modifications, (such as portable ramps at the entrance and accessible parking spaces marked off by traffic cones) until permanent modifications can be made. However, where facilities are not capable of being made accessible, another facility will need to be selected for use as a shelter.

## **Step One: Accessible Shelter Quick-Check Survey**

### **Selecting Sites to Survey for Accessibility**

Providing an emergency shelter that is accessible to people with disabilities involves making sure that a number of accessible features and spaces are available. To verify accessibility before deciding on a site for an emergency shelter can involve asking many questions such as those in the ADA Checklist for Emergency Shelters. For some older buildings, especially those on hilly sites and those that have not been renovated, remodeled, or altered since 1992, before completing the detailed checklist, it may be better to do a pre-test that can rule out a facility with major accessibility problems so available resources can be focused on other locations. The following questions will help evaluate whether a facility has such major accessibility barriers. After this first step, buildings that do not have major accessibility problems should be surveyed more thoroughly, using the ADA Checklist for Emergency Shelters, to find out which, if any, barriers need to be removed to provide an accessible shelter.

#### **A. Accessible Entrance**

Having a way to get into the emergency shelter on a surface that is firm, stable, slip resistant, without steps or steep slopes, and wide enough for a person using a wheelchair or other mobility aid is essential.

A1. Is there a sidewalk connecting the parking area and any drop off area to the walkway leading to the building? [ADA Standards § 4.1.3(1)]

Yes

No

A2. Is there a route without steps from this sidewalk to the main entrance?

Yes

No

If No, are there two or fewer steps? Yes \_\_\_\_\_ No \_\_\_\_ Number of Steps: \_\_\_\_\_

If No, is there another entrance without steps that is connected by a sidewalk to the parking or drop off area? Yes \_\_\_\_\_ No \_\_\_\_ Location: \_\_\_\_\_

### **B. Accessible Routes To All Service/Activity Areas**

Everyone must be able to get to each of the various areas where activities and services take place. This includes people who use mobility devices, such as wheelchairs and scooters, being able to get to locations where supplies are distributed, to eating areas, to sleeping areas, to toilet rooms, and to other activity areas without encountering stairs or steep slopes.

Check all of the various ways to get to each of the areas where sheltering activities are likely to take place (sleeping, eating,

B1. Sleeping Area (Location: \_\_\_\_\_)

B1-a. Is there a route without steps from the accessible entrance to this location?

Yes

No

If No, are there two or fewer steps? Yes \_\_\_\_ No \_\_\_\_ Number of Steps: \_\_\_\_\_

If No, is there a ramp, lift, or elevator? Yes \_\_\_\_ No \_\_\_\_ Type of device: \_\_\_\_\_

B1-b. If an elevator or lift provides the only accessible route, is there a source of backup power to operate the device for an extended period?

Yes

No

B2. Eating Area (Location: \_\_\_\_\_)

B2-a. Is there a route without steps from the accessible entrance to this location?

Yes

No

If No, are there two or less steps? Yes \_\_\_ No \_\_\_ Number of Steps: \_\_\_\_\_

If No, is there a ramp, lift, or elevator? Yes \_\_\_ No \_\_\_ Type of device: \_\_\_\_\_

B2-b. If an elevator or lift provides the only accessible route, is there a source of back up power to operate the device for an extended period?

Yes

No

B3. Supply Distribution Area (Location: \_\_\_\_\_)

B3-a. Is there a route without steps from the accessible entrance to this location?

Yes

No

If No, are there two or fewer steps? Yes \_\_\_ No \_\_\_ Number of Steps: \_\_\_\_\_

If No, is there a ramp, lift, or elevator? Yes \_\_\_ No \_\_\_ Type of device: \_\_\_\_\_

B3-b. If an elevator or lift provides the only accessible route, is there a source of backup power to operate the device for an extended period?

Yes

No

B4. Toilet Rooms (Location: \_\_\_\_\_)

B4-a. Is there a route without steps from the accessible entrance to this location?



Yes

No

If No, are there two or fewer steps? Yes \_\_\_ No \_\_\_ Number of Steps: \_\_\_\_\_

If No, is there a ramp, lift, or elevator? Yes \_\_\_ No \_\_\_ Type of device: \_\_\_\_\_

B4-b. If an elevator or lift provides the only accessible route, is there a source of backup power to operate the device for an extended period?

Yes

No

### **C. Accessibility Within Toilet Rooms**

C1-a. Is there an area within the toilet room where a person who uses a wheelchair or mobility device can turn around - either a minimum 60-inch diameter circle or a "T"-shaped turn area? [ADA Standards §§ 4.22.3; 4.2.3, Fig. 3]

Yes

No

C1-b. Is at least one stall at least 66 inches deep and 36 inches wide (wall mounted toilet) or 69 inches deep and 48 inches wide (floor mounted toilet)? [FBC Standards § 11-4.17.3]

Yes

No

### **Using The Information:**

If most of your answers to the previous questions are Yes, then the facility has some basic accessibility features and should be surveyed using the ADA Checklist for Emergency Shelters. Whenever most of your answers are No, then these problems should be evaluated before conducting a more detailed survey, or perhaps you should consider another location to serve as an emergency shelter.

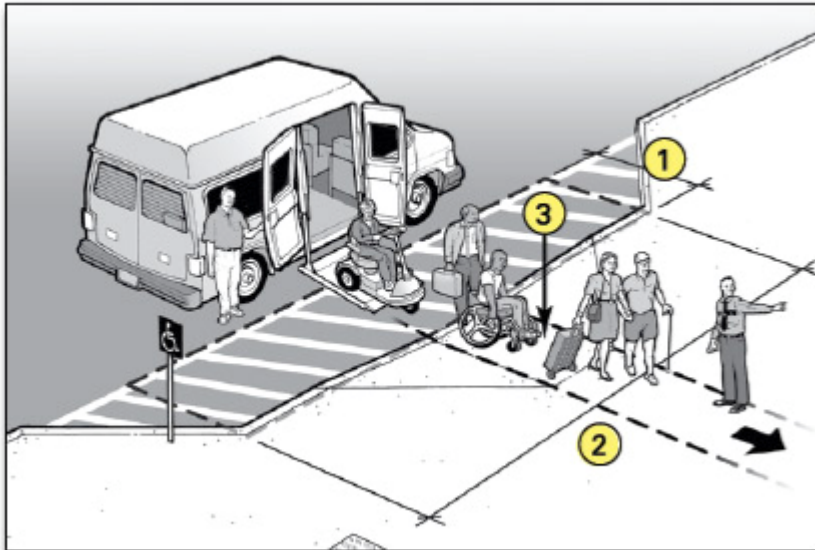
## **Step Two - ADA Checklist For Emergency Shelters**

## Getting to the Emergency Shelter

### A. Passenger Drop-Off Areas

During an evacuation the most efficient method of transporting people to shelters likely will include using vans and buses. Accessible buses and vans with wheelchair lifts will be needed to transport people who use wheelchairs, scooters, or other mobility aids. When they arrive at the shelter, an accessible drop-off area (also known as a passenger loading zone) is needed for people using mobility aids to get off of the bus or van and proceed to the shelter's accessible entrance.

An accessible drop-off area must have a level access aisle that is adjacent and parallel to the vehicle space. Where a curb separates the vehicle space from the access aisle or the access aisle from an accessible route, a curb ramp must be provided so people with mobility disabilities can get to the accessible route leading to the accessible entrance of the shelter.



**Accessible drop-off area with an access aisle provided at the same level as the vehicle.**

#### Notes

1. Access aisle depth is at least 5 feet.
2. Access aisle length is at least 20 feet. 3.
3. Curb ramp connects the access aisle for the accessible drop-off area (which is at the level of the parking lot) to the accessible route to the accessible entrance of the shelter.

The access aisle may be at the parking-lot level or at sidewalk level. If the access aisle is at the parking-lot level, the curb ramp is provided between the access aisle and the

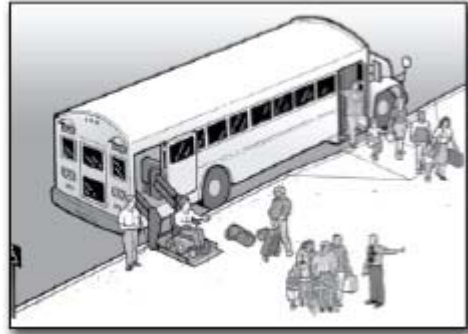
sidewalk. If it is at the sidewalk level, an adjacent curb ramp is provided between the street and the sidewalk.

A1. Is a relatively level (1:50 or 2% maximum slope in all directions) access aisle provided adjacent and parallel to the side of the vehicle pull-up area? [ADA Standards § 4.6.6]

Yes

No

If No, look for another relatively level location that is on an accessible route to the accessible shelter entrance that could be used.



**Accessible drop-off area with an access aisle provided as part of the sidewalk.**

A2. Is the vehicle pull-up area relatively level (1:50 or 2% maximum slope in all directions)?

Yes

No

A3. Is the area for the access aisle at least 5-feet wide and 20-feet long? [ADA Standards § 4.6.6].

Yes

No

*Note: Unlike at an accessible parking space, the surface for the access aisle of an accessible passenger drop-off area does not have to be marked or striped.*

A4. Is there vertical clearance of at least 114 inches (9 feet 6 inches) from the site entrance to the vehicle pull-up area, the access aisle, and along the vehicle route to the exit? [ADA Standards § 4.6.5]

Yes

No

A5. Is a curb ramp provided between the vehicle pull up area and the access aisle (see above) or the access aisle and the accessible route to the accessible entrance? [ADA Standards § 4.6.6]

Yes

No

If No, is there another area with a curb ramp and on an accessible route that could serve as the drop-off area?

If there is no curb ramp near the drop-off area, can a temporary ramp be used to connect the drop-off area access aisle to the accessible route to the accessible shelter entrance?

A6. If a curb ramp is provided, is the running slope of the ramp surface (not counting the side flares) no more than 1:12 or 8.33% [ADA Standards § 4.7.2]

Yes

No

A7. Is the width of the curb ramp surface at least 36 inches (not counting the side flares)? If the curb ramp is part of a required means of egress, its width must be 44 inches. [ADA Standards § 4.7.3, FBC 11-4.7.3]

Yes

No

A8. Does an accessible route connect the curb ramp to the shelter's accessible entrance? [ADA Standards § 4.1.2(1)]

Yes

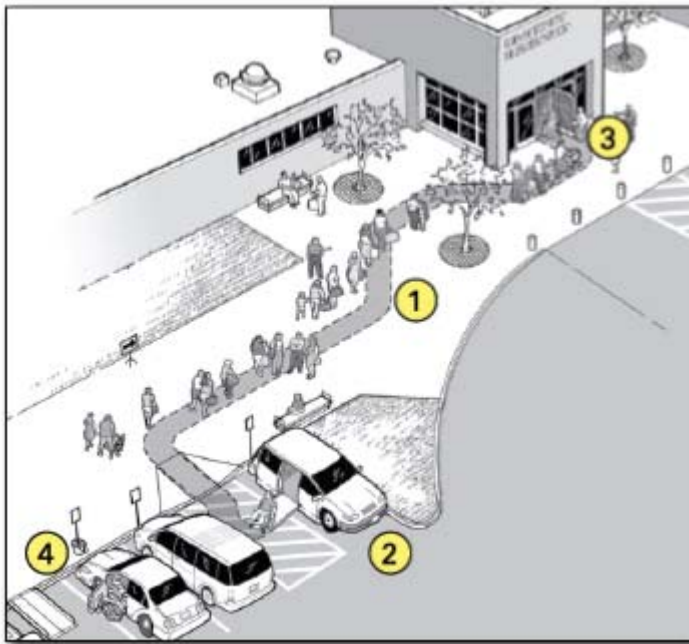
No

## **B. Parking**

### **1. Typical Issues**

During an evacuation, some individuals with a mobility disability may arrive at the shelter in a car or van. When parking areas are provided at the shelter site, accessible parking spaces must be provided. Individuals with disabilities who arrive at the shelter in their own car or van need to be able to park in an accessible parking space close to an accessible entrance. Accessible parking spaces need an adjacent access aisle that provides space for a person with a mobility disability to exit their vehicle. The access aisle connects directly to an accessible route that leads to an accessible building entrance. In order to be usable, the access aisle must be relatively level, clear of gravel or mud, and the surface must be in good condition without wide cracks or broken pavement.

An accessible route connects the permanent access aisle of each accessible parking space with the accessible entrance to the shelter. When an accessible route crosses a curb, a curb ramp must be provided. During an emergency, as a temporary measure, if additional accessible parking spaces are needed, a portable ramp can be provided in a parking space marked off by traffic cones to provide two additional accessible parking spaces (see page 18).



**An accessible entrance to an emergency shelter with accessible parking and additional temporary accessible parking spaces**

**Notes:**

1. Accessible route.
2. Accessible parking with van accessible parking space.
3. Accessible entrance to shelter.
4. Temporary accessible parking spaces.

**2. Parking Spaces Checklist**

B1. When parking areas are provided at the shelter site, count the total number of parking spaces provided in each area. Is the minimum number of accessible parking spaces provided, based on the total number of available parking spaces (see table below)? [FBC Standards § 4.1.2(5)(a)]

Yes

No

**Total Number of Parking Spaces in Each Parking Area**

**Required Minimum Number of Accessible Spaces**

<b>1- 25</b>	<b>1</b>
<b>26 - 50</b>	<b>2</b>
<b>51 - 75</b>	<b>3</b>
<b>76 - 100</b>	<b>4</b>
<b>101 - 150</b>	<b>5</b>

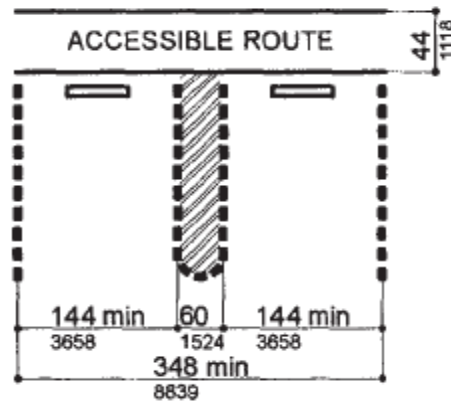
If more than 150 parking spaces are provided in a particular lot, see section 4.1.2 of the ADA Standards for the number of accessible parking spaces required.

B2. Does each accessible parking space have its own, or share, an adjacent access aisle that is at least 60 inches (5 feet) wide? [ADA Standards § 4.6.3]

Yes

No

**FIGURE 9(A)  
STANDARD PARKING SPACE DESIGN**



**Accessible Parking Spaces Showing Minimum Width of Vehicle Space and Access Aisle**

B3. Are all accessible spaces located on an accessible route no less than 44 inches (1118 mm) wide so that users will not be compelled to walk or wheel behind parked vehicles. [FBC Standards § § 4.6.2(1)]

Yes

No

B5. Are all accessible parking spaces, including the access aisle, relatively level (1:50 or 2%) in all directions? [ADA Standards § 4.6.3]

Yes

No

If No: Look for a nearby area that is relatively level in all directions that could serve as an accessible parking space with an accessible route to the accessible entrance to the shelter.

B6. Does each accessible parking space have a sign with the symbol of accessibility that is visible (84 inches above ground level) when a vehicle is parked in the space? [ADA Standards § 4.6.4, Florida Statutes 553.5041 (6)]

Yes

No

B7. Is the curb ramp surface at least 44 inches wide, excluding flared sides? [FBC Standards § 4.7.3]

Yes

No

B7-a. Is the slope (up or down the ramp) no more than 1:12? [ADA Standards § 4.7.2]

Yes

No

Note: 1:12 is one inch of vertical height for each 12 inches of length.

B8. Are the accessible parking spaces serving the shelter on the shortest accessible route to the accessible entrance? [ADA Standards § 4.6.2]

Yes

No

B9. Does each access aisle connect to an accessible route from the parking area to the shelter's accessible entrance? [ADA Standards § 4.6.2]

Yes

No

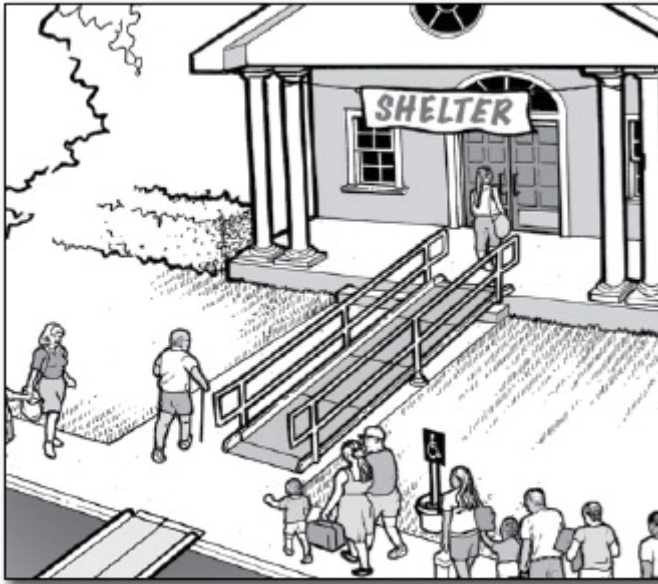
### 3. Temporary Solutions for Emergency Sheltering - Parking

**Problem:** Parking at the shelter facility either has no accessible parking, not enough accessible parking, or accessible parking spaces are not on level ground.

**Suggestion:** Find a fairly level parking area near the accessible entrance and mark the area for accessible parking spaces. Three regular parking spaces will make two accessible parking spaces with a shared access aisle. Provide a sign designating each accessible parking space. Ensure there is an accessible route from each access aisle to the accessible entrance.

If temporary accessible spaces are used, mark the temporary accessible parking spaces with traffic cones or other temporary elements. Traffic cones can also be used to mark off an access aisle if designated accessible parking spaces lack an access aisle or if the access

aisle is too narrow. At least one accessible parking space should be a van-accessible parking space with an access aisle that is at least 96 inches wide.



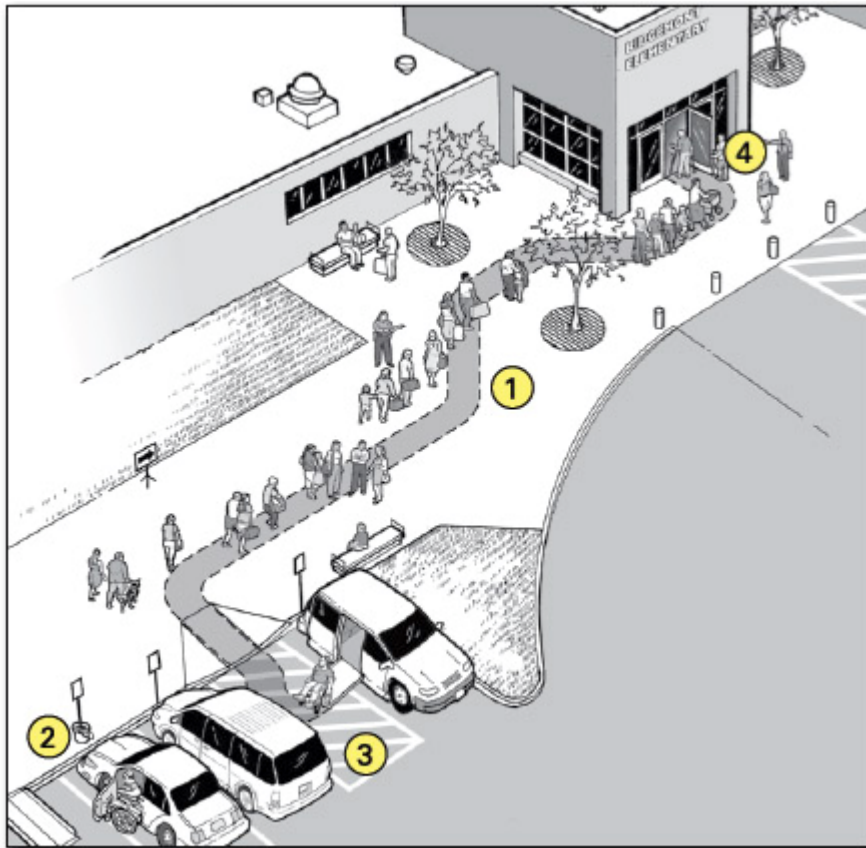
**Three standard parking spaces are converted into an accessible parking space with an access aisle. Cones mark the access aisle and a temporary curb ramp with edge protection connects to an accessible route to the shelter.**

### **C. Sidewalks and Walkways**

#### **1. Typical Issues for Individuals Who Use Wheelchairs, Scooters, or other Mobility Devices**

An accessible route connects accessible passenger drop-off areas, accessible parking spaces, and other accessible elements, like a route from a bus stop, to an accessible building entrance. The accessible route is essential for people who have difficulty walking or who use wheelchairs or other mobility aids to get to the accessible entrance of the shelter. The accessible route must be at least 36 inches wide (FBC- 44 inches wide if a required means of egress) (it may narrow briefly to 32 inches wide where utility poles, signs, etc. are located along the accessible route). Abrupt level changes, steps, or steep running or cross slopes cannot be part of an accessible route. Where ramps are used, they cannot be steeper than 1:12. Ramps with a vertical rise of more than 6 inches must have handrails on both sides. Ramps must also have edge protection to stop wheelchairs from falling off the sides, and level landings at the top and bottom of each segment and where the ramp changes direction.





**An accessible entrance to a shelter with accessible parking and an accessible drop-off area**

**Notes:**

- 1. Accessible route
- 2. Accessible drop-off area
- 3. Accessible entrance to shelter

C1-a. Is an accessible route provided from accessible parking spaces to the accessible entrance of the shelter? [ADA Standards § 4.1.2(1), 4.3]

Yes

No

C1-b. Is an accessible route provided from public sidewalks and public transportation stops on the shelter site (if provided) to the accessible entrance for the shelter? [ADA Standards § 4.1.2(1)]

Yes

No

Note: The accessible route is at least 36 inches wide (44 inches wide if part of a required means of egress) and may be a portion of a sidewalk.

C1-c. Is the accessible route at least 36 inches wide (44 inches wide if part of a required means of egress)? [ADA Standards § 4.3.3]

Yes

No

If No, does the accessible route narrow to 32 inches for no more than 2 feet?

C1-d. Is the accessible route free of steps and abrupt level changes higher than 1/2 inch? [ADA Standards § 4.3.8]

Yes

No

Note: Level changes between 1/4 inch and 1/2 inch should be beveled (sloped) at 1:2 maximum.

C1-e. Where an accessible route crosses a curb, is a curb ramp provided? [ADA Standards § 4.3.8]

Yes

No

e-i. Is the curb ramp surface at least 36 inches wide (44 inches wide if part of a required means of egress), excluding flared sides? [ADA Standards § 4.7.3]

Yes

No

e-ii. Is the running slope (up or down the ramp) no more than 1:12? [ADA Standards § 4.7.2]

Yes

No

Note: 1:12 is one 12 inches of horizontal distance for every 1 inch of vertical rise..

C1-f. If the slope of part of the accessible route is more than 1:20, does it meet the following requirements for an accessible ramp?

Yes

No

f-i. Is the running slope no greater than 1:12? [ADA Standards § 4.8.2]

Yes

No

Note: For existing ramps, the slope may be 1:10 for a 6-inch rise and 1:8 for a 3-inch rise in special circumstances (see ADA Standards § 4.1.6(3)).

f-ii. Are handrails installed on both sides of each ramp segment? [ADA Standards § 4.8.5]

Yes

No

f-iii. Is the ramp width, measured between the handrails, at least 36 inches (44 inches wide if part of a required means of egress)? [ADA Standards § 4.8.3]

Yes

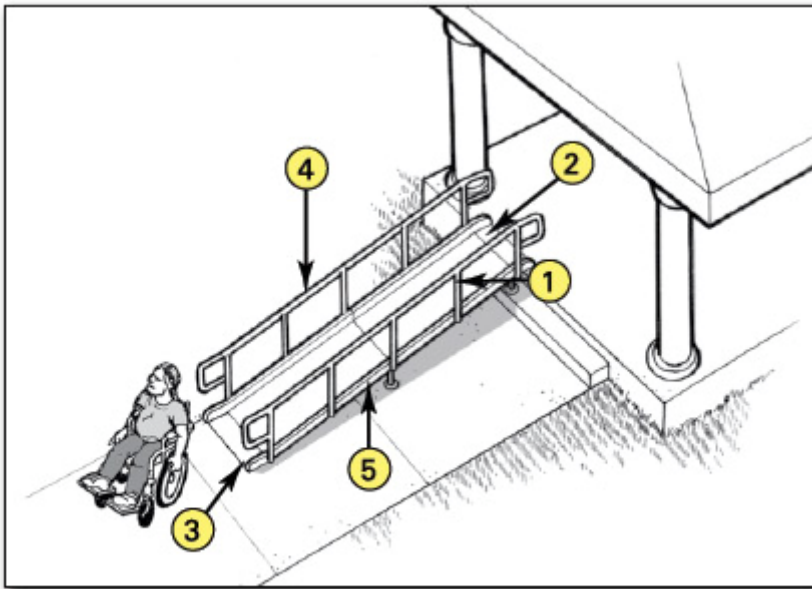
No

f-iv. Does the ramp have a level landing at the top and bottom of each ramp section that is at least 60 inches long (the bottom of each ramp shall have no less than 72 inches of straight and level clearance)? [ADA Standards § 4.8.4]

Yes

No

Note: The level landing may be part of the sidewalk or walking surface.



**Accessible ramp features**

**Notes:**

1. At least 36 inches between handrails (FBC – 44 inches if part of a required means of egress)

2. Top landing part of walk

3. Bottom landing part of walk (FBC – 72 inches straight and level area required)

4. Handrail height 34 to 38 inches

5. Edge protection.

f-v. If a ramp is more than 30 feet long, is a level landing at least 60 inches long provided at every 30 feet of horizontal length? [ADA Standards § 4.8.4]

Yes

No

*Note: if the running slope is less than 1:16 but more than 1:20, each ramp segment may be up to 40 feet long followed by a level landing.*

f-vi. Is there a level landing, at least 60 inches x 60 inches, when a ramp changes direction? [ADA Standards § 4.8.4]

Yes

No

f-vii. Are the handrails mounted 34 to 38 inches above the ramp surface? [ADA Standards § 4.8.5]

Yes

No

f-viii. If the ramp or landing has a vertical drop-off on either side, is edge protection provided? [ADA Standards § 4.8.7]

Yes

No

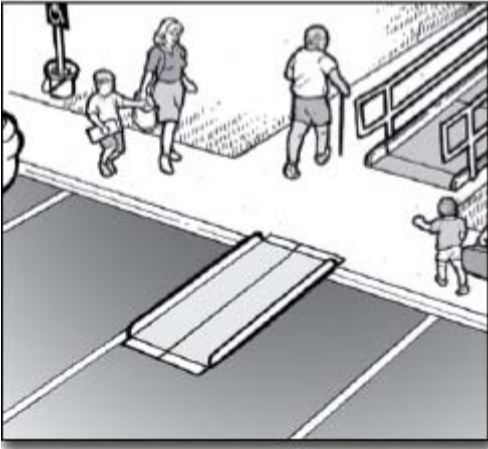
### **Temporary Solutions For Emergency Sheltering - Ramps**

**Problem:** The sidewalk connecting parking to the shelter entrance is too steep to be accessible.

**Suggestion:** Check to see if there is another accessible route to the accessible entrance. Sometimes there is a less direct route that is accessible. During an evacuation it will be helpful to put up signs or to have volunteers stationed at the accessible parking spaces to direct people along this less direct, but nonetheless accessible, route.

**Problem:** The accessible route crosses a curb but no curb ramp is provided.

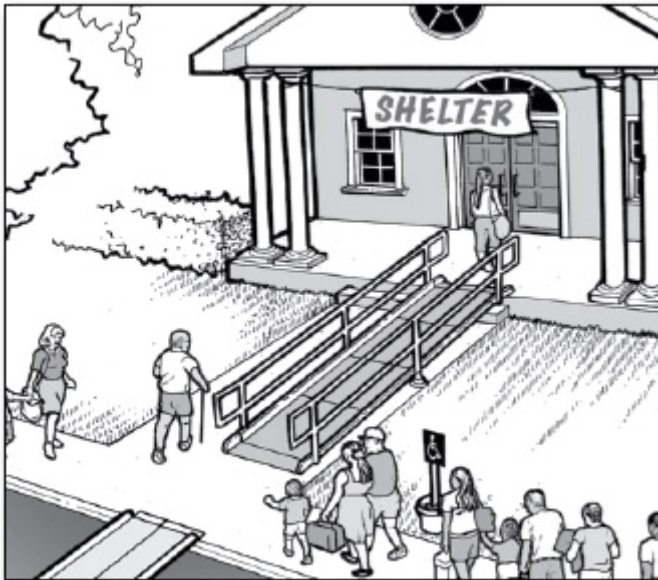
**Suggestion:** Install a portable ramp with a slope no steeper than 1:12 with edge protection. Store the portable ramp on site so it can be easily accessed in an emergency.



**A portable ramp with edge protection is installed over a curb to provide an accessible route.**

**Problem:** There are two steps where the sidewalk connects to the accessible entrance.

**Suggestion:** Install a portable ramp with a slope no steeper than 1:12 with edge protection and handrails on both sides of the ramp. Store the portable ramp and components on site so everything can be easily accessed in an emergency.

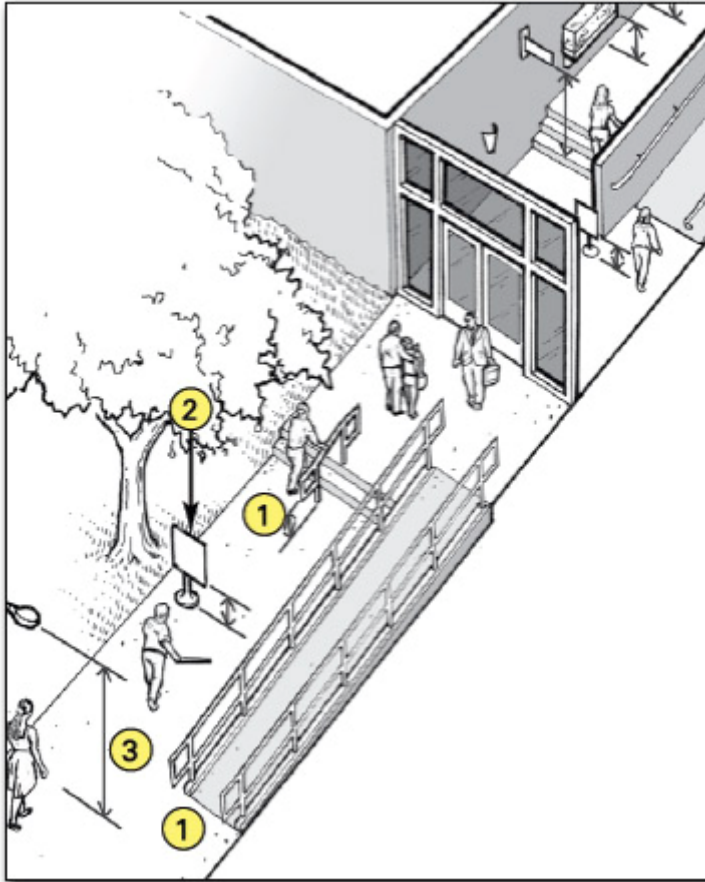


**A portable ramp with edge protection and handrails is installed over two steps to provide an accessible route.**

## **2. Typical Issues for Individuals Who Are Blind or Have Low Vision**

Objects that are wall mounted, that project into a pedestrian route from the side, or that are overhead can be hazards to people who are blind or who have low vision. These objects must be positioned so people will either detect the objects before they run into them or safely pass under them. Examples may include handrail extensions on stairs and

ramps, post- or wall-mounted signs, drinking fountains, and low hanging tree limbs. Pedestrian routes open to people during the time that the facility is being used as an emergency shelter, such as sidewalks, courtyards, and plazas, must be free of overhanging objects that are less than 80 inches above the route. Objects more than 27 inches and less than 80 inches above the route and that protrude from the side more than 4 inches are also a hazard. Since people can walk on any sidewalk, not just the accessible routes, all exterior pedestrian routes serving or leading to the shelter areas must be checked. The following questions apply to sidewalks and walkways leading to the emergency shelter.



**Common objects along pedestrian routes to a shelter that can be hazards to people who are blind or have low vision.**

**Notes:**

1. The bottom of the handrail extensions turn down to 27 inches or less above the route so a person who is blind or has low vision can detect the hazard before running into it.
2. Signs or other objects in the pedestrian route can be a hazard if the bottom is more than 27 inches but less than 80 inches above the route.
3. Objects that overhang the pedestrian route must be at least 80 inches above the route.

C2-1. Are all sidewalks and walkways to the shelter free of any objects (e.g., wall-mounted boxes, signs, handrail extensions) with bottom edges that are between 27 inches and 80 inches above the walkway and that extend more than 4 inches into the sidewalk or walkway? [ADA Standards §§ 4.4, 4.2.1(3), 4.1.3(2)]

Yes

No

If No, can the object be lowered, removed, or modified or can the route be moved so that the object can be avoided?

C2-2. Are the undersides of exterior stairs enclosed or protected with a cane-detectable barrier so that people who are blind or have low vision will not hit their heads on the underside? [ADA Standards § 4.4.2]

Yes

No

If No, can a barrier or enclosure be added below the stair or can the route be relocated away from the stair?



**When the underside of a stair is open, it is a hazard to people who are blind or have low vision. Enclosing the area below the stair or installing a cane-detectable barrier helps this woman to stop before hitting her head.**

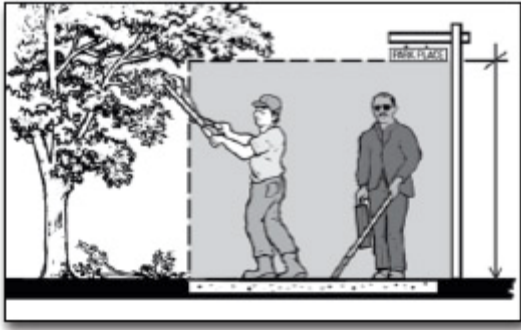
C2-3. Are all objects that hang over the pedestrian routes at least 80 inches above the route? [ADA Standards § 4.4.2]

Yes

No



If No, can the objects be removed or relocated, or can a cane-detectable object be added below that is at no higher than 27 inches?



**Overhead sign and tree branches are least 80 inches above the walk.**

### **Temporary Solutions For Emergency Sheltering - Protruding Object Hazards**

**Problem:** Objects protrude too far from the side into the route causing a hazard for people who are blind or who have low vision.

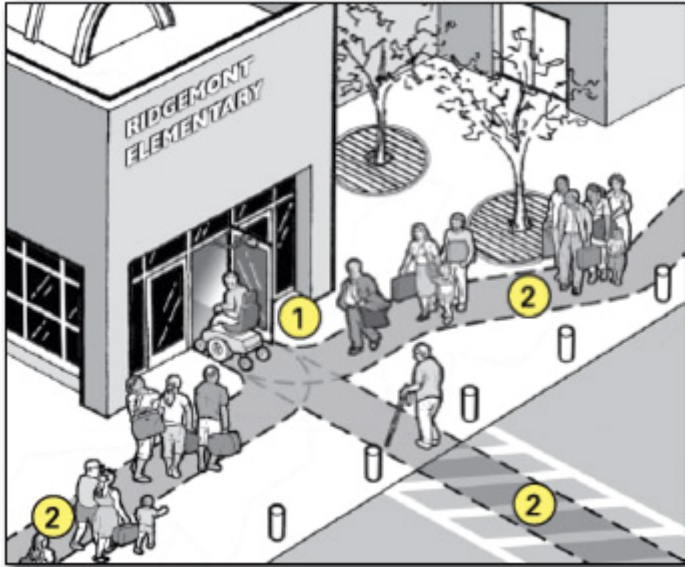
**Suggestion:** When people who are blind or who have low vision use a cane to detect hazards, objects located at 27 inches or lower are detectable. When an object is located higher than 27 inches above the ground it is a hazard if the object protrudes more than 4 inches into the circulation path. To make a protruding object cane-detectable:

- Place an object below, or on either side of, the protruding object that is not higher than 27 inches above the ground.
- If the protruding object can be moved, lower the object so that its bottom is not more than 27 inches above the ground.
- Prune or alter the protruding object so it does not protrude above the route.

## **D. Entering the Emergency Shelter**

### **Building Entrance**





**Notes:**

1. Accessible entrance to the shelter.
2. Accessible route connecting accessible parking and drop-off area (if provided) to the accessible entrance.

A shelter must have at least one accessible entrance that is on an accessible route. An accessible entrance must provide at least one accessible door with maneuvering space, accessible hardware, and enough clear width to allow people who use crutches, a cane, walker, scooter, or wheelchair to use it.

If the accessible entrance is not the main entrance to the facility that is being used as a shelter, signs must be located at inaccessible entrances to direct evacuees and volunteers to the accessible entrance. The accessible entrance must be unlocked when other shelter entrances are unlocked.



**Examples of signs for inaccessible shelter entrances directing people to the accessible entrance.**

D1. Is there at least one accessible entrance connected to an accessible route? [ADA Standards § 4.1.3(1)]

Yes

No

Notes: If this entrance is not the main entrance, it needs to be kept unlocked when other shelter entrances are unlocked.

If there are inaccessible entrances serving the shelter, signs will be needed at inaccessible entrance(s) to direct evacuees to the nearest accessible entrance.

D2. Does at least one door or one side of a double leaf-door provide at least 32 inches clear passage width when the door is open 90 degrees? [ADA Standards § 4.13.5]

Yes

No

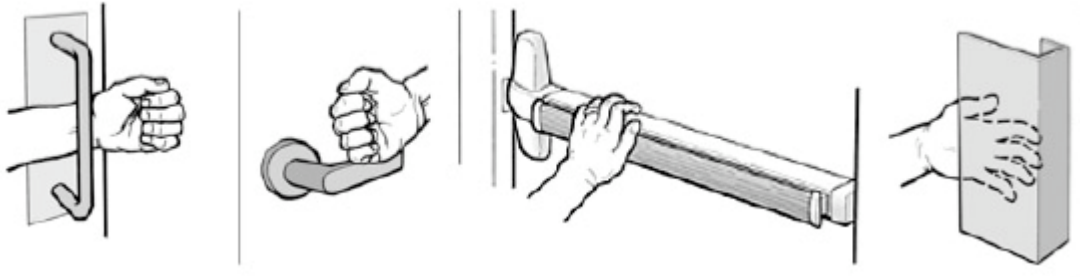
If No, does another entrance have an accessible door or can both doors be propped open during the evacuation? Other possible solutions are to enlarge the door opening, use a swing clear hinge, or, if a double-leaf door, replace with uneven width doors.

D3. Is the hardware (e.g., lever, pull, and panic bar) usable with one hand without tight grasping, pinching, or twisting of the wrist? [ADA Standards § 4.13.9]

Yes

No

If No, leave door propped open, add new accessible hardware, or adapt/replace hardware.



**Examples of handles and door hardware that can be used without tight grasping, pinching, or twisting.**

D4. On the latch, pull side of the door, is there at least 18 inches clearance provided if the door is not automatic or power-operated? [ADA Standards § 4.13.6, Fig. 25]

Yes

No

If No, leave the door propped open or find another accessible entrance.

D5. If there is a raised threshold, is it no higher than 3/4 inch at the door and beveled on both sides? [ADA Standards §§ 4.1.6(3)(d)(ii), 4.13.8]

Yes

No

If No, replace threshold with one with beveled sides or add a sloped insert.

D6. If an entry has a vestibule, is there a 30-inch by 48-inch clear floor space inside the vestibule where a wheelchair or scooter user can be outside the swing of a hinged door? [ADA Standards § 4.13.7]

Yes

No

If No, leave the inner door permanently open, remove inner door, or modify the vestibule.

D7. Does the amount of effort to open an exterior hinged door exceed 8.5 lbf.? [FBC 4.13.11(2)(a)]

Yes

No

If No, adjust door closing mechanism or provide assistant to open door.

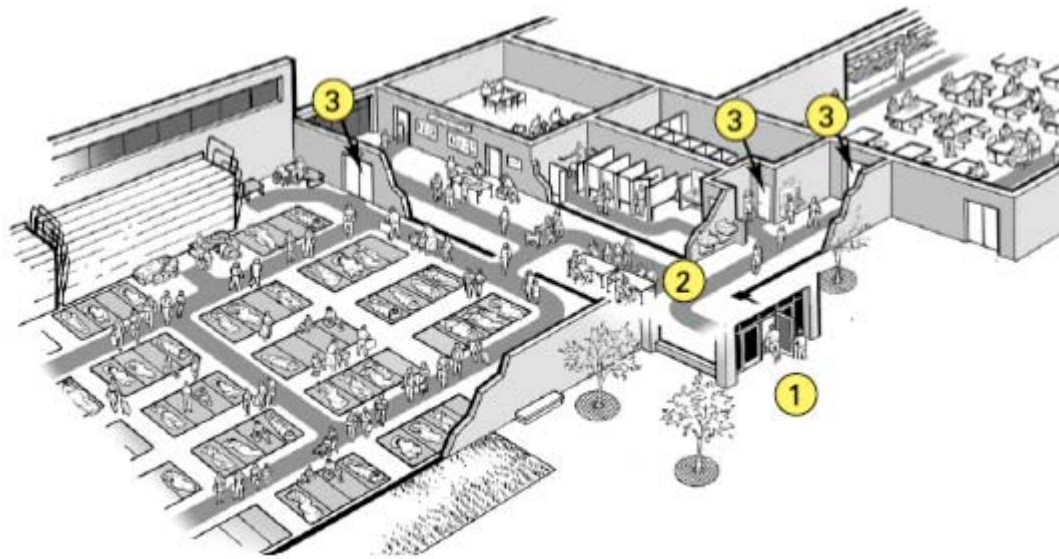
## E. Hallways and Corridors

### 1. Typical Issues for Individuals Who Use Wheelchairs, Scooters, or Other Mobility Devices

The interior accessible route connects the accessible entrance with the various service and activity areas within the shelter. Typically made up of hallways, corridors, and interior rooms and spaces, the accessible route is essential for people who have difficulty walking or who use wheelchairs or other mobility aids to get to all of the service and activity areas of the shelter.

An accessible route is at least 36 inches wide (FBC – 44 inches wide if a required means of egress) and may narrow briefly to 32 inches wide where the route passes through doors or next to furniture and building elements. High thresholds, abrupt level changes, steps, or steep running or cross slopes cannot be part of an accessible route. Where ramps are used, they cannot be steeper than 1:12. Ramps with a vertical rise of more than 6 inches must have handrails on both sides. Ramps must also have edge protection to stop wheelchairs from falling off the sides, and level landings at the top and bottom of each segment and where a ramp changes direction.

Where an accessible route is different from the route used by most evacuees, signs will be needed at key decision points to direct individuals with disabilities to the various activity areas.



**Interior of a shelter showing the accessible route from the accessible entrance to all service and activity areas.**

#### Notes:

1. Accessible Entrance

2. Accessible Route connects the accessible entrance with shelter service and activity area
3. Accessible door to service and activity areas

E1-a. Is there an accessible route, at least 36 inches wide (FBC – 44 inches wide if a required means of egress), that connects the accessible entrance to all shelter areas (it may narrow to 32 inches wide for up to 2 feet in length)? [ADA Standards § 4.3.2(3)]

Yes

No

E1-b. Is the accessible route free of steps and abrupt level changes over 1/2 inch?

Yes

No

Note: level changes between 1/4 inch and 1/2 inch should be beveled). [ADA Standards §§ 4.1.3(1), 4.3.8]

E1-c. Does the accessible route from the accessible entrance to all activity areas change levels using a ramp, lift or elevator? [ADA Standards §§ 4.1.3(1), 4.3.8]

Yes

No

If No, go to question E1-g.

c-i. If Yes, is a ramp or sloped hallway provided?

Yes

No

If Yes, go to question E1-d.

c-ii. Is an elevator or lift provided?

Yes

No

If Yes, and the elevator or lift is part of the accessible route to a shelter area, is back-up electrical power available to operate the elevator or lift for the duration of shelter operation should the normal electrical service be disrupted?

If Yes and an elevator is provided, see question E1-e.

If Yes and a lift is provided, see question E1-f.

If No, then either provide back-up electrical power to operate the lift or elevator during the power outage or locate shelter services exclusively on accessible levels that may be reached by people with a mobility disability without using an elevator or lift.

E1-d. Where the slope of the accessible route is greater than 1:20, does this area meet the following requirements for an accessible ramp?

Yes

No

d-i. Is the slope no greater than 1:12? [ADA Standards § 4.8.2]

Yes

No

Note: For existing ramps, the slope may be 1:10 for a 6-inch rise and 1:8 for a 3-inch rise in special circumstances]. [ADA Standards § 4.1.6(3)]

d-ii. Are handrails installed on both sides of each ramp segment? [ADA Standards § 4.8.5]

Yes

No

d-iii. Is the ramp width, measured between handrails, at least 36 inches (FBC – 44 inches if a required means of egress)? [ADA Standards § 4.8.3]

Yes

No

d-iv. Are the handrails mounted 34 to 38 inches above the ramp surface? [ADA Standards § 4.8.5]

Yes

No

d-v. If a ramp is longer than 30 feet, is a level landing at least 60 inches long provided every 30 feet? [ADA Standards § 4.8.4]

Yes

No

d-vi. Does the ramp have a level landing that is at least 60 inches long at the top and 72 inches of straight and level clearance at the bottom (FBC – 11.4.8.4(2)) of each ramp section or where the ramp changes direction? [ADA Standards § 4.8.4]

Yes

No

d-vii. If the ramp or landing has a vertical drop-off on either side of the ramp, is edge protection provided? [ADA Standards § 4.8.7]

Yes

No

E1-e. Is an elevator provided to each of the levels on which each sheltering service or activity area is located?

Yes

No

e-i. Are the centerlines of the call buttons mounted 42 inches above the floor? [ADA Standards § 4.10.3]

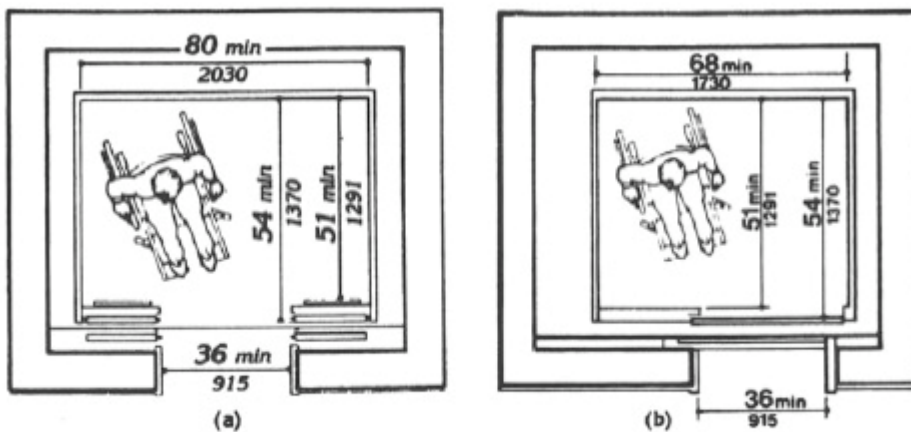
Yes

No

e-ii. Does the floor area of the elevator car have space to enter, reach the controls, and exit? [ADA Standards § 4.10.9, Fig. 22]

Yes

No



**Fig. 22**  
**Minimum Dimensions of Elevator Cars**

*Note: See Figure 22 for acceptable floor and opening dimensions. Floor dimensions of at least 48 inches by 48 inches may be allowed in existing facilities built before the ADA went into effect.*

e-iii. Can the elevator be called and operated automatically without using a special key or having to turn on the elevator from a remote location? [ADA Standards § 4.10.2]

Yes

No

e-iv. Are the highest floor control buttons mounted no more than 54 inches above the floor for a side reach or 48 inches for forward reach? [ADA Standards § 4.10.12 (3)]

Yes

No

e-v. Are raised letters and Braille characters used to identify each floor button and each control? [ADA Standards § 4.10.12]

Yes

No

e-vi. Are signs mounted on both sides of the elevator hoist way door opening (for each elevator and at each floor) that designate the floor with 2-inch minimum-height raised letters and Braille characters centered at 60 inches above the floor? [ADA Standards § 4.10.5]

Yes

No

e-vii. Is the elevator equipped with audible tones or bells or verbal annunciators that announce each floor as it is passed? [ADA Standards § 4.10.13]

Yes

No

E1-f. If a wheelchair lift is provided, does it meet the following?

Yes

No

f-i. Is the lift operational at the time of the survey? [ADA Standards § 4.11.3]

Yes

No

f-ii. Is the change in level from the floor to the lift surface ramped or beveled? [ADA Standards §§ 4.11.2, 4.5.2]

Yes

No

f-iii. Is there at least a 30-inch by 48-inch clear floor space on the wheelchair lift? [ADA Standards §§ 4.11.2, 4.2.4]

Yes

No

f-iv. Does the lift allow a person using a mobility device unassisted entry, operation (is key available, if required), and exit?



Yes

No

f-v. Are the controls and operating mechanisms mounted no more than 54 inches above the floor for a side reach or 48 inches for a forward reach? [ADA Standards §§ 4.11.2, 4.27.3]

Yes

No

f-vi. Are the controls and operating mechanisms usable with one hand without tight grasping, pinching, or twisting? [ADA Standards §§ 4.11.2, 4.27.4]

Yes

No

E1-g. At each location on the way to each shelter activity area where the accessible route passes through a door, does at least one door meet the following requirements?

Yes

No

g-i. Is the clear width for the door opening at least 32 inches measured when the door is open 90 degrees? [ADA Standards §§ 4.1.3(7), 4.13.5]

Yes

No

g-ii. Is the door hardware (e.g., lever, pull, push, panic bar) usable with one hand, without tight grasping, pinching, or twisting of the wrist, to allow people who may not be able to easily use one or both hands to fully operate the hardware? [ADA Standards § 4.13.9]

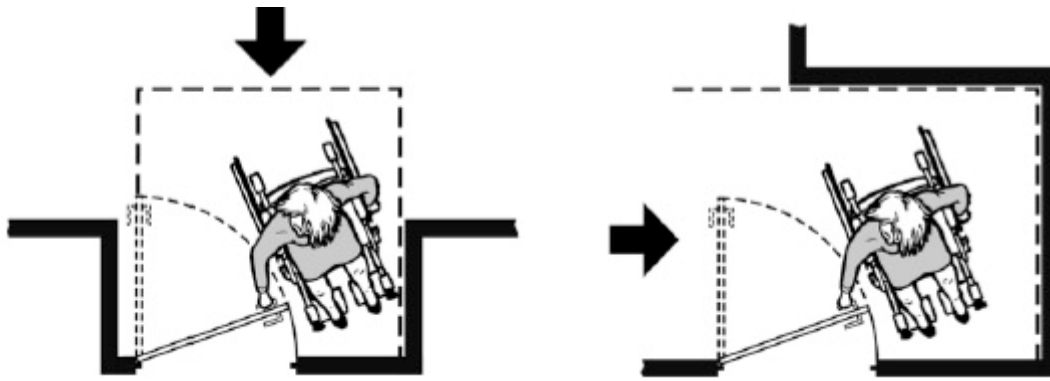
Yes

No

g-iii. Is there clear maneuvering floor space in front of each accessible door (see ADA Standards § Fig. 25) and, on the pull side, is there at least 18 inches clear floor space beyond the latch side of the door (see space configurations in Figure 25)? [ADA Standards § 4.13.6]

Yes

No



**A clear floor space on the latch side of the door (pull side) allows a person using a wheelchair or scooter to pull the door open and then enter. The size of the clear floor space varies depending on the direction of approach (shown by the arrows) and the door swing.**

g-iv. Is no more than 5 pounds force needed to push or pull open the door? [ADA Standards § 4.13.11 (2)(b)]

Yes

No

Note: Fire doors are still considered to be accessible if they have the minimum opening force allowable by the appropriate administrative authority.

g-v. If the answers to questions g-ii thru g-iv are No, can the door be propped open?

Yes

No

If an activity area is not on an accessible route and cannot be made accessible, find another area that is on an accessible route where that activity may be provided.

## **2. Typical Issues for People Who are Blind or Have Low Vision**

Individuals who are blind or have low vision may walk along any route or through any shelter activity area, not just the accessible routes. That means any area where people using the shelter can walk, including hallways, corridors, eating areas, and sleeping areas, must be free of objects that cannot be detected by a person who is blind or has low vision. Objects that are wall mounted, that project into a pedestrian route from the side, or that are overhead must be located so that individuals who are blind or have low vision will either detect the objects before they run into them or safely pass under them. These routes must be free of overhanging objects that are less than 80 inches above the floor and side objects that protrude into the route more than 4 inches when the bottom of the object is more than 27 inches above the floor. Items to watch for include wall-mounted fire extinguishers and wall-mounted display cases when the bottom is more than 27 inches above the floor, wall sconces and light fixtures that protrude more than 4 inches off the

wall, and open staircases, exit signs, overhead signs, banners, and arched doorways that are lower than 80 inches above the floor.



**Overhead and wall-mounted objects that may be hazards along a pedestrian route**

**Notes:**

1. Wall-mounted drinking fountains are a hazard when the front projects more than 4 inches beyond the wall and the bottom is more than 27 inches above the floor.
2. Wall-mounted objects cannot project more than 4 inches beyond the wall if the bottom is not in the cane-detectable area below 27 inches off the floor.
3. Overhead objects must be at least 80 inches off the floor.

The following questions apply to pedestrian routes serving or leading to the shelter activity and common use areas.

E2-a. Are pedestrian routes leading to or serving each service or activity area of the shelter free of objects that protrude from the side more than 4 inches into the route with the bottom of the object more than 27 inches above the floor? [ADA Standards § 4.4.1]

Yes

No

Note: These objects may be wall mounted or free standing. Items to check include wall-mounted fire extinguishers, light fixtures, coat hooks, shelves, drinking fountains, and display cases.

E2-b. Are pedestrian routes leading to or serving each of the service or activity areas free of overhead objects with the bottom edge lower than 80 inches above the floor? [ADA Standards § 4.4.2]

Yes

No

E2-c. Are any interior stairs along these routes configured with a cane-detectable warning or a barrier that prevents travel into the area with less than an 80-inch high head clearance so that people who are blind or who have low vision cannot hit their heads on the underside or stair frame? [ADA Standards § 4.4.2]

Yes

No

If No, list the objects that are a hazard and their location. Remove or relocate the object or place a detectable object on the floor below each object to remove the hazard.



**When the underside of a stair is open, it is a hazard to people who are blind or have low vision. Enclosing the area below the stair or installing a cane detectable barrier helps the person to avoid the area.**

## **F. Check-In Areas**

A shelter usually has one or more check-in areas located near the entrance to the shelter. When check-in areas are provided, then at least one accessible check-in location should

be provided. The accessible check-in area should be at the accessible entrance or signs should give directions to the accessible check-in area.

If a permanent reception counter is used for check in, make sure to provide a writing surface at an accessible height for people who use a wheelchair, scooter, or other mobility device. This may be a part of the reception counter that is no higher than 36 inches above the floor, a folding shelf or an adjacent table, or a clip board.



**An accessible check-in location using a folding table with a height that people who use wheelchairs can easily reach.**

F1. Is there an accessible route that connects the accessible entrance to areas that are likely to be used to register people as they arrive at the shelter? [ADA Standards § 4.3]

Yes

No

F2. If there is a built-in reception or other type of counter, does it have a section that is at least three feet long that is no higher than 36 inches above the floor or is there a nearby surface that is not higher than 36 inches above the floor? [ADA Standards § 7.2]

Yes

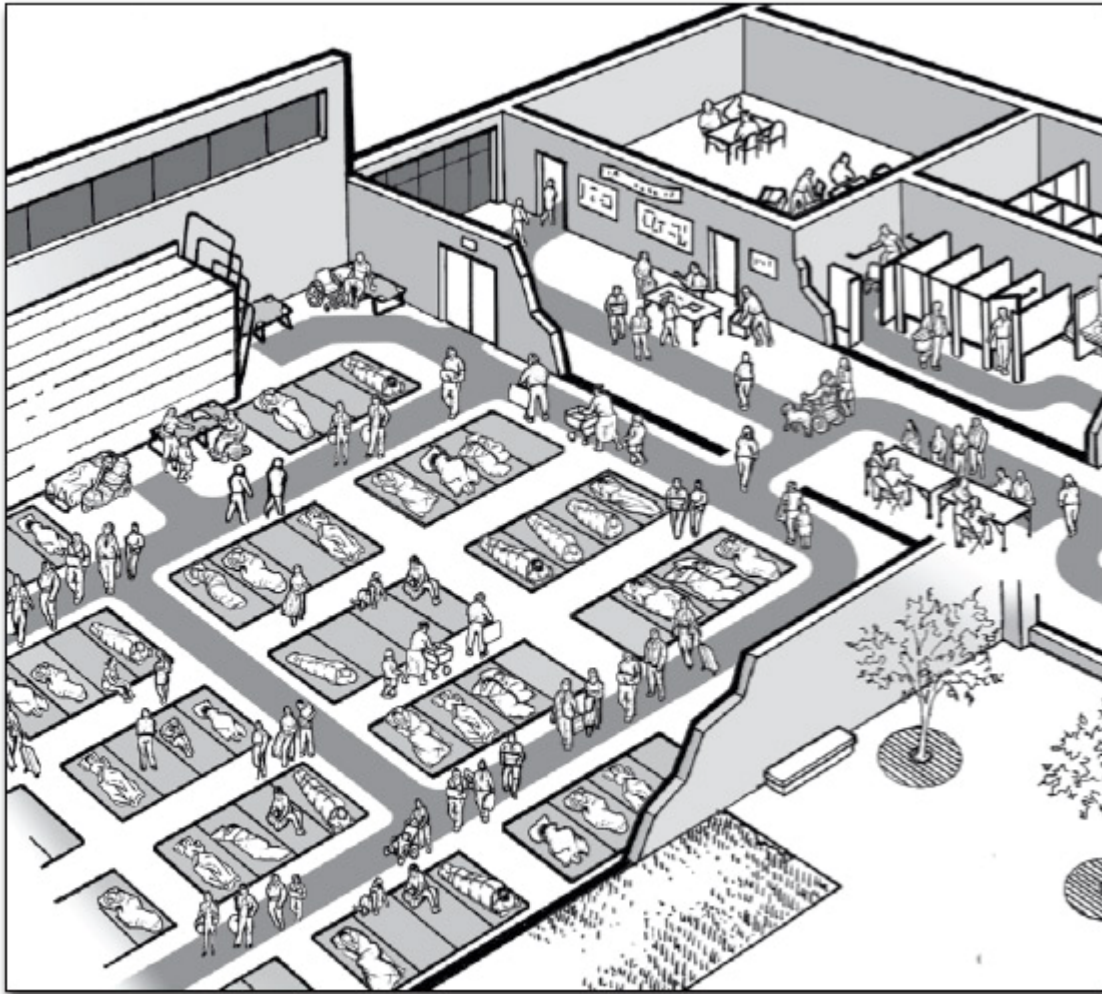
No

## **Living at the Emergency Shelter**

### **G. Sleeping Areas**

Each accessible sleeping area needs to be on an accessible route connecting it to other activity areas in the shelter, including toilet rooms and bathing areas. An accessible route with adequate circulation and maneuvering space provides access in the sleeping areas

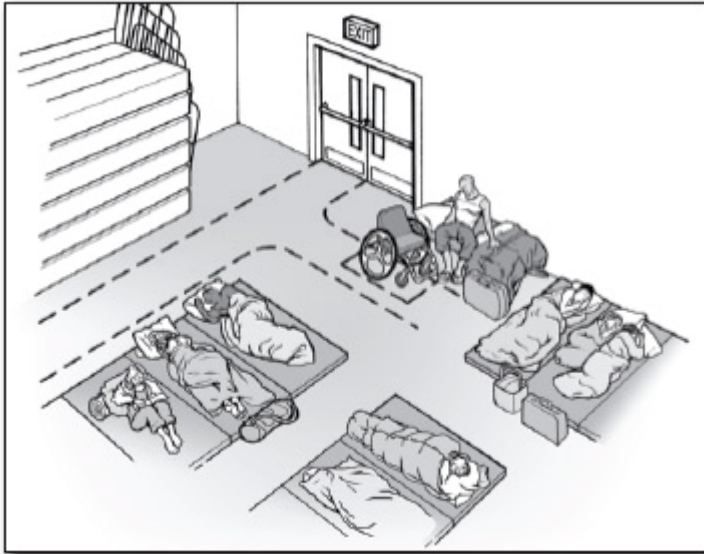
for people who use wheelchairs or scooters and this route serves each accessible bed or cot.



**Interior of one section of a shelter's sleeping area. The shaded pathway indicates the accessible route, which provides access to accessible beds, cots, and other activity areas in the space plus the toilet rooms and other activity areas in the shelter.**

Accessible cots have a sleeping surface at approximately the same height above the floor as the seat of a wheelchair (17 to 19 inches above the floor). When placed in several sections of the sleeping area, individuals who use a wheelchair, scooter, or other mobility device will be able to sleep near their family or other companions. An accessible route is needed to provide access to each accessible cot and a clear space at least 36 inches wide (FBC – 44 inches wide if a required means of egress) is needed along the side of the cot to make it possible to transfer between the mobility device and the cot. A preferred location for accessible cots is to have one side against a wall. This helps to stabilize the cot and the wall can act as a backrest when the person sits up on the cot.





**An accessible cot positioned against a wall. Dashed lines indicate the accessible route and clear floor space next to the cot.**

G1. Is there an accessible route, at least 36 inches wide (FBC – 44 inches wide if a required means of egress), that connects each sleeping area with other shelter activity areas?

Yes

No

Note: it may narrow to 32 inches wide for up to 2 feet in length. [ADA Standards § 4.3.2(3)]

G2. Is the accessible route free of steps and abrupt level changes over 1/2 inch?

Yes

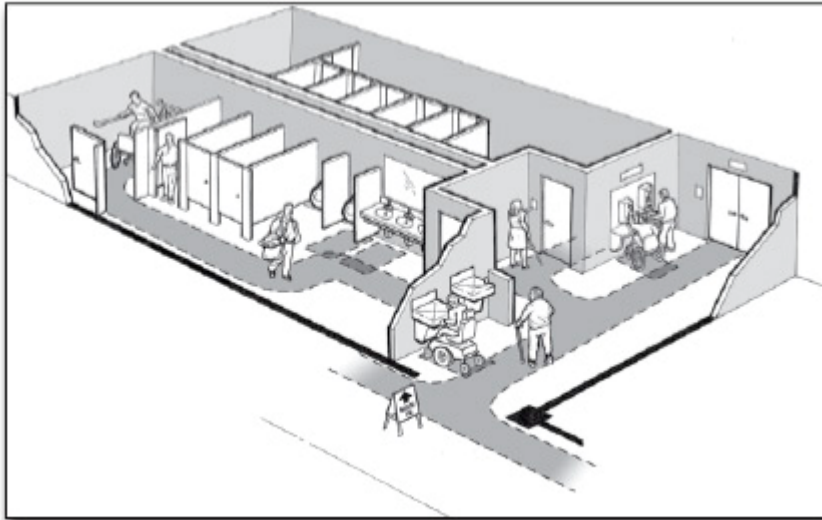
No

Note: level changes between 1/4 inch and 1/2 inch should be beveled). [ADA Standards §§ 4.1.3(1), 4.3.8]

Note: Although the facility survey cannot check the accessibility of the cots because they will not be installed until the shelter is in use, planning for setting up the sleeping area and for arranging the cots and mats should include providing space for an accessible route and clear floor space at each accessible cot. Cots used by people who are blind or who have low vision should be in an easily locatable area.

## H. Restrooms and Showers

At least one set of toilet rooms serving the shelter must be accessible to individuals who use a wheelchair, scooter, or other mobility device. In large shelters where more than one set of toilet rooms is needed to serve the occupants, it may be necessary to provide additional accessible toilet facilities or to establish policies to assure that individuals with disabilities have access to the accessible facilities.



**Interior of an accessible toilet room showing accessible route, clear floor space at accessible fixtures, and the wide accessible toilet stall.**

H1. If a sign is provided at the toilet room entrance (e.g. Men, Women, Boys, Girls, etc.), is a sign with raised characters and Braille mounted on the wall adjacent to the latch? [ADA Standards § 4.30.6]

Yes

No

If No, install a sign with raised characters and Braille on the wall adjacent to the latch side of the door and centered 60 inches above the floor and leave the existing sign in place on the door if removing it will damage the door.

Note: an additional sign may be mounted on the toilet room door but this cannot be considered to be the accessible sign which must be mounted on the wall adjacent to the latch side of the door.

H2. Does the door to the toilet room provide at least 32 inches clear passage width when the door is open 90 degrees? [ADA Standards § 4.13.5]



Yes

No

H3. Is the hardware (e.g., lever, pull, panic bar) usable with one hand without tight grasping, pinching, or twisting of the wrist? [ADA Standards § 4.13.9]

Yes

No

If No, can the door be propped open without compromising privacy, or can the hardware be modified by adding new accessible hardware, or adapting or replacing hardware?

H4. On the pull side of the door, is there at least 18 inches clearance provided on the latch side if the door is not automatic or power-operated? [ADA Standards § 4.13.6, Fig. 25]

Yes

No

H5. If there is a raised threshold, is it no higher than 3/4 inch at the door and beveled on both sides? [ADA Standards §§ 4.1.6(3)(d)(ii), 4.13.8]

Yes

No

NA

If No, replace threshold with one with beveled sides or add a sloped insert.

H6. If the entry has a vestibule, is there a 30-inch by 48-inch clear floor space inside the vestibule where a wheelchair or scooter user can be outside the door swing? [ADA Standards § 4.13.7]

Yes

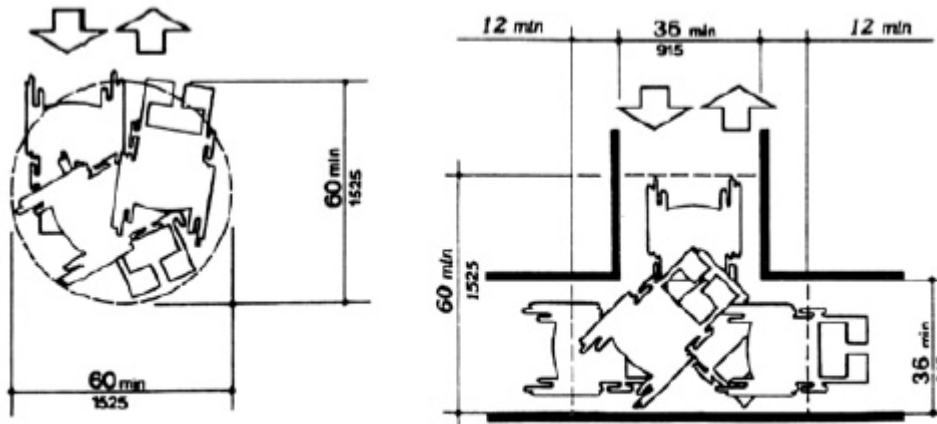
No

If No, possible solutions include leaving the inner door open or removing the outer door.

H7. Inside the toilet room, is there an area where a person who uses a wheelchair or other mobility device can turn around - either at least 60-inch diameter circle or a "T"-shaped turn area as shown in the figures below? [ADA Standards §§ 4.22.3; 4.2.3]

Yes

No



**Minimum spaces for turning**

**Minimum spaces for turning**

H8. If lavatories are provided, does at least one have at least a 29 inch high clearance under the front apron with the top of the rim no more than 34 inches above the floor? [ADA Standards § 4.19.2]

Yes

No

H9. Are the drain and hot water pipes for this lavatory insulated or otherwise configured to protect against contact? [ADA Standards § 4.19.4]

Yes

No

H10. Does this lavatory have controls that operate easily with one hand, without tight grasping, pinching, or twisting of the wrist? [ADA Standards § 4.19.5]

Yes

No

H11. If mirrors are provided, is the bottom of the reflecting surface for the mirror at this lavatory no higher than 40 inches above the floor or is a full length mirror provided? [ADA Standards § 4.19.6]

Yes

No

H12. For at least one of each type of dispenser, receptacle, or equipment, is there clear floor space at least 30 inches wide x 48 inches long adjacent to the control or dispenser (positioned either parallel to the control or dispenser or in front of it)? [ADA Standards §§ 4.23.7; 4.27.2; 4.2.5 and Fig 5; 4.2.6 and Fig 6]

Yes

No

H13. Is the operating control (switch, lever, button, or pull) of at least one of each type of dispenser or built-in equipment no higher than 54 inches above the floor (if there is clear floor space for a parallel approach) or 48 inches (if there is clear floor space for a front approach)? [ADA Standards §§ 4.23.7; 4.27.3; 4.2.5 and Fig 5; 4.2.6 and Fig 6]

Yes

No

H14. Are all built-in dispensers, receptacles, or equipment mounted so the front does not extend more than 4 inches from the wall if the bottom edge is between 27 inches and 80 inches above the floor? [ADA Standards §§ 4.23.7; 4.27; 4.4.1; Fig. 8]

Yes

No

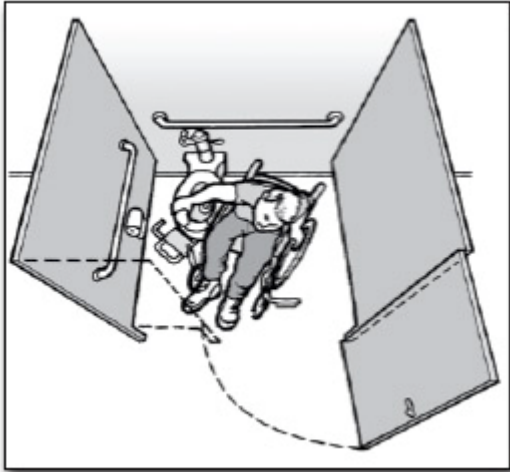
### **Toilet Stalls**

H15. Is at least one wide toilet stall provided with an out swinging door, side and rear grab bars, and clear space next to the toilet? [ADA Standards § 4.17]

Yes

No

If No, check to see if another toilet room provides a wide accessible toilet stall, note its location for shelter planners, and answer all toilet room questions with respect to that toilet room.



**Overhead view of an individual using a wheelchair positioned beside a toilet in a wide accessible stall.**

H16. Is the toilet stall at least 60 inches wide and 56 inches deep (wall mounted toilet) or 59 inches deep (floor mounted toilet)? [ADA Standards § 4.17.3]

Yes

No

If No, note the width and depth of the stall. \_\_\_\_\_

H17. Is at least 9 inches of toe clearance provided under the front wall and at least one side wall of the toilet stall? [ADA Standards § 4.17.4]

Yes

No

H18. Is the centerline of the toilet 18 inches from the adjacent side wall? [ADA Standards § 4.16.2; 4.17.3]

Yes

No

H19. Is the top of the toilet seat 17 inches to 19 inches above the floor? [ADA Standards § 4.16.3]

Yes

No

H20. Is the flush valve located on the wide side adjacent to the lavatory or is an automatic flush valve provided? [ADA Standards § 4.16.5]

Yes

No

H21. Is a horizontal grab bar at least 40 inches long securely mounted on the adjacent side wall 33 to 36 inches above the floor with one end no more than 12 inches from the back wall 33 to 36 inches above the floor? [ADA Standards § 4.16.4; 4.17.6]

Yes

No

H22. Is a second horizontal grab bar at least 36 inches long securely mounted on the back wall with one end no more than 6 inches from the side wall 33 to 36 inches above the floor? [ADA Standards § 4.16.4; 4.17.6]

Yes

No

H23. Is the door to the toilet stall located diagonally opposite, not directly in front of, the toilet or on the opposite side wall from the wall with the long grab bar? [ADA Standards § 4.17.3]

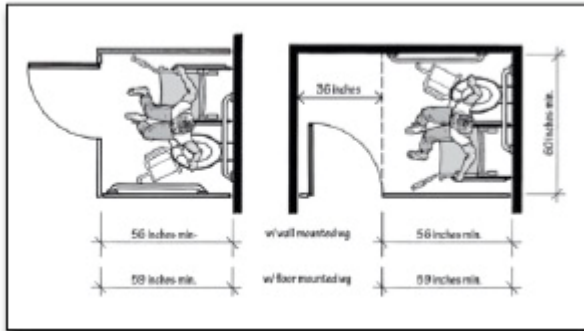
Yes

No

H24. Unless the wide stall is located at the end of a row of toilet stalls, does the door to this wider stall open out? [ADA Standards § 4.17.3]

Yes

No



**Plan views showing minimum sizes of wide accessible toilet stall**

H25. Is the clear width of the door at least 32 inches (measured between the face of the door and the edge of the opening) when the door is open 90 degrees? [ADA Standards § 4.13.5]

Yes

No

H26. If there are 6 or more stalls in the restroom, is one of those stalls (in addition to the wider stall noted above) exactly 36 inches wide with an out swinging stall door that provides at least 32 inches of clear width? [ADA Standards § 4.22.4]

Yes

No

H27. Does this 36-inch wide stall have horizontal grab bars on both of the side partitions that are at least 36 inches long and 33 to 36 inches above the floor? [ADA Standards § 4.22.4]

Yes

No

H28. Is the surface of the toilet seat in this 36-inch-wide stall 17 to 19 inches above the floor? [ADA Standards §§ 4.16.3; 4.22.4]

Yes

No

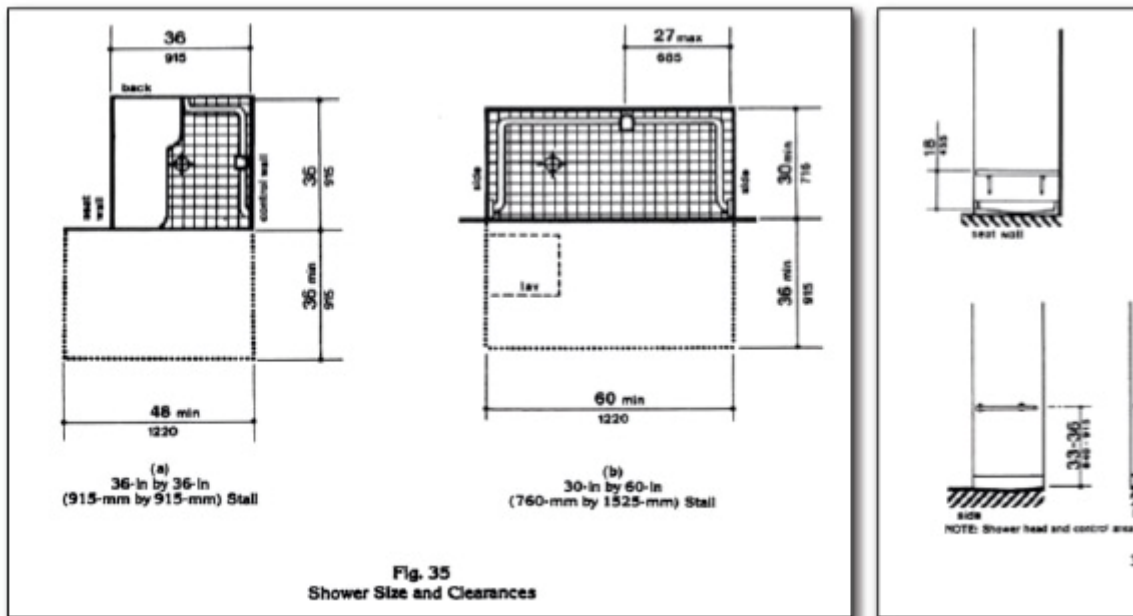
H29. If a coat hook is provided is it mounted no higher than 54 inches above the floor for a side approach or 48 inches above the floor for a front approach? [ADA Standards § 4.25.3]

Yes

No

Note: For many emergency shelters, evacuees are not expected to use shower or bathing facilities due to the short period they may stay at the shelter. If planning for the shelter operation includes offering shower or bathing facilities, then those facilities should be on an accessible route and checked for accessibility. For information on the requirements for accessible showers or bathtubs see the ADA Standards for Accessible Design which is available online at [www.ada.gov](http://www.ada.gov).

**The following are figures illustrating some accessible shower features from the ADA Standards.**



**Accessible Shower Stall  
Minimum Size and Clearances**

**Accessible Shower Stall Grab Bars  
and Seat, Shower, and Control Area**

## I. Public Telephones

When public telephones are provided, then one or more accessible public telephones should be provided in areas serving shelter activity and service areas. Whenever accessible telephones are provided, each should be on an accessible route. In shelters it is common to provide additional telephones on tables or desks and some of these telephones should be accessible.

A text telephone (also commonly known as a TTY) is a device that allows individuals who are deaf or hard of hearing or who have a speech disability to communicate over a telephone. Having at least one TTY in any building that has at least four pay phones, provides access for people who are deaf or hard of hearing.

11. If at least one public telephone or one bank of telephones is provided, does at least one of each type of telephone (e.g., pay telephone, intercom telephone, other telephone) have the following?

Yes

No

11a. For a side approach (clear floor space at least 30 inches long x 48 inches wide), is the coin slot no higher than 54 inches above the floor? [ADA Standards § 4.31.2, Fig. 44 (a)]

Yes

No

11b. For a front approach (where clear floor space at least 30 inches wide x 48 inches long), is the coin slot no higher than 48 inches above the floor? [ADA Standards § 4.31.2, Fig. 44 (b)]

Yes

No

12. Does the phone have volume controls? [ADA Standards § 4.31.5]

Yes

No

13. If three or more telephones are located in one bank serving the shelter, are a shelf and an electrical outlet provided at one telephone for use of a portable TTY? [ADA Standards § 4.31.9 (2)]

Yes

No

14. If four or more pay telephones are provided on the site, is there a TTY (text telephone) provided at the shelter?



Yes

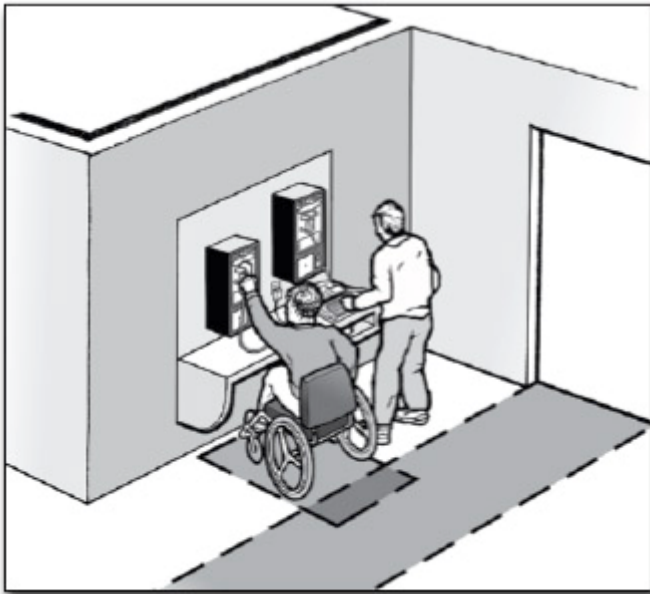
No

If yes, location\_\_\_\_\_

15. Is there a sign at each pay phone or pay phone bank for the shelter directing people to the nearest TTY? [ADA Standards § 4.30.7 (3); 4.31.9(3)]

Yes

No

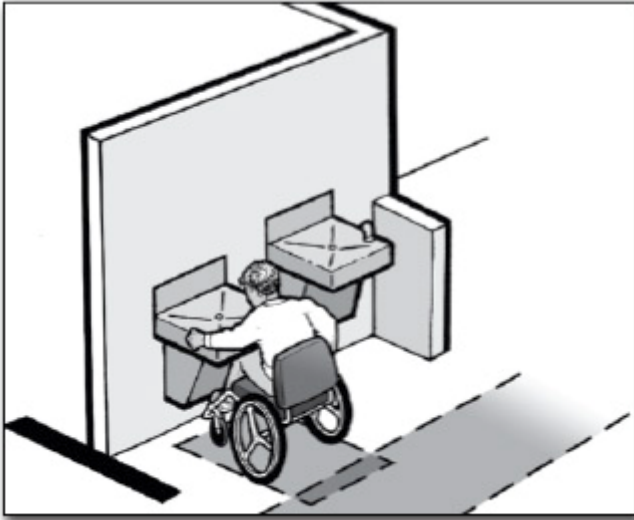


**A bank of two public telephones. The accessible telephone is on the left and the telephone on the right is equipped with a TTY.**

## **J. Drinking Fountains**

Approximately 50% of the drinking fountains serving the shelter must be accessible and located on an accessible route. Accessible drinking fountains must have enough space for a person using a wheelchair, scooter, or other mobility device to use the drinking fountain. The spout and controls of the drinking fountain must be near the front edge. The controls must be usable with one hand without tight grasping, pinching, or twisting of the wrist. The other 50% of drinking fountains serving the shelter must be configured for use by people who have difficulty bending or stooping while standing.

When an object, such as a drinking fountain, protrudes more than four inches into the circulation path, the bottom edge must be at 27 inches above the floor or lower so the drinking fountain is not a hazard to people who are blind or have low vision.



**A person who uses a wheelchair is drinking from an accessible drinking fountain. Beside the accessible drinking fountain is a standard height fountain that is usable by people who have difficulty bending or stooping. The short wall beside the standard height drinking fountain is cane-detectable to guide people who are blind or have low vision away from the standard height fountain which, otherwise, would be a protruding object hazard.**

**The following questions apply to 50% of the drinking fountains that are provided.**

J1. If the drinking fountain is a wall-mounted unit, is there clear floor space at least 30 inches wide (36 inches if it is in an alcove) x 48 inches long in front of the drinking fountain and at least 27 inches high under the fountain so that a person using a wheelchair can get close to the spout and controls? [ADA Standards § 4.15.5 (1), Figs. 4 (e) and 27 (b)]

Yes

No

J2. If the drinking fountain is a floor-mounted unit, is there clear floor space at least 30 inches long x 48 inches wide (60 inches if it is in an alcove) for a side approach to the drinking fountain so that a person using a wheelchair can get close to the spout and controls even though the fountain has no clear space under it? [ADA Standards § 4.15.5 (2), Figs. 4 (e), 27 (c) and (d)]

Yes

No

J3. Is the top of the spout no higher than 36 inches above the floor and at the front of the fountain or water cooler? [ADA Standards § 4.15.2]

Yes

No

J4. Does the water rise at least 4 inches high when no more than 5 pounds of force is applied to the controls of the fountain? [ADA Standards §§ 4.15.3 and 4.15.4]

Yes

No

J5. Are the controls on or near the front of the unit and do they operate with one hand without tight grasping, pinching, or twisting of the wrist? [ADA Standards § 4.15.4]

Yes

No

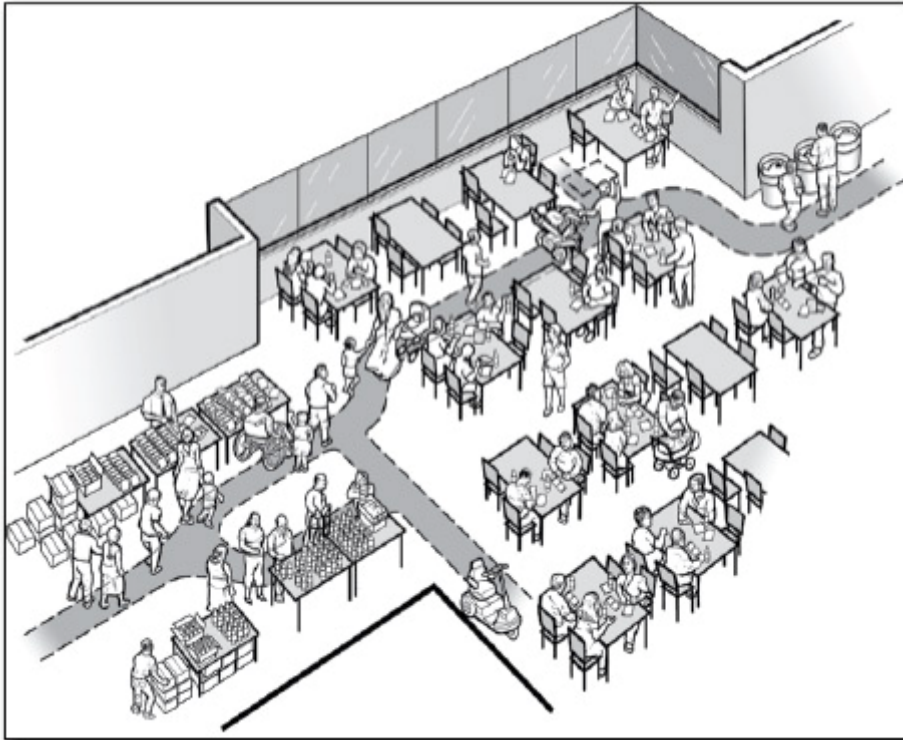
J6. Is the bottom of the apron of the fountain 27 inches above the floor so that it provides the space needed for a person who uses a wheelchair to pull up under it but is not a hazard to people who are blind or have low vision and use a cane to detect hazards? [ADA Standards §§ 4.15.5 (1) and 4.4.1]

Yes

No

## **K. Eating Areas**

An accessible route, at least 36 inches wide and without steps or steep slopes, must be provided to and throughout the food service and eating areas of the shelter. The accessible route allows people who use wheelchairs, scooters, and other mobility devices to get to all of the food and drink items in the shelter and to accessible tables and seating.



**A serving and eating area in a shelter are shown above. The shaded pathway illustrates the accessible route connecting the entrance, serving areas, accessible seats and tables, and the exit.**

K1. Is there an accessible route, at least 36 inches wide (FBC – 44 inches wide if a required means of egress), that connects each of the shelter activity areas with the food service and eating areas (it may narrow to 32 inches wide for up to 2 feet in length)? [ADA Standards § 4.3.2(3)]

Yes

No

K2. Is there an accessible route that is at least 36 inches wide (FBC – 44 inches wide if a required means of egress), that connects accessible tables with serving, condiment, and dispenser areas? [ADA Standards § 5.3; 4.3.8]

Yes

No

K3. In each eating area, if tables with fixed seats are provided, do at least 5% of each type of table with fixed seats have accessible locations with knee space at least 27 inches high, at least 19 inches deep, and at least 30 inches wide with a table top 28 to 34 inches above the floor? [ADA Standards § 5.1]

Yes

No

Note: If movable tables and chairs are used as shown, then locate at least 5% of the tables adjacent to an accessible route. Tables can be relocated as needed during operation of the shelter.

K4. If built-in food, drink, condiment, and tableware dispensers are provided, are dispensers and operating controls mounted no higher than 54 inches above the floor if clear floor space is provided for a side approach? [ADA Standards § 5.5]

Yes

No

K5. If the operating controls are set back 10 to 24 inches from the front edge of the counter or table are they no higher than 46 inches above the floor? [ADA Standards § 5.5]

Yes

No

K6. If food service lines are provided, is an accessible route provided (at least 36 inches wide) and are the tray slides no higher than 34 inches above the floor? [ADA Standards § 5.5]

Yes

No

## **Other Issues**

### **L. Availability of Electrical Power**

Emergency shelters should have a way to provide a back-up power supply when the electrical service is interrupted. The back-up power is needed to provide refrigeration of medicines, operation of supplemental oxygen and breathing devices, and for charging the batteries of power wheelchairs and scooters. Individuals whose medications (certain types of insulin, for example) require constant refrigeration need to know if a shelter provides supplemental power for refrigerators or ice-packed coolers. Individuals who use medical support systems, such as supplemental oxygen, or who require periodic breathing treatments using powered devices rely on a stable source of electricity. These individuals

must have access to electric power from a generator or other source of electricity while at a shelter.

In general, in each community or area where a shelter is provided, a facility must have one or more back-up generators or other sources of electricity so that evacuees with a disability who rely on powered devices can have access to electrical power while at the shelter.



L1. Is there a backup source of electrical power for the facility?

Yes

No

L2. Is there a refrigerator or other equipment, such as coolers with a good supply of ice, at the shelter?

Yes

No

### **M. Single-User or “Family” Toilet Room**

In many schools and large facilities where emergency shelters are often located, single-user toilet rooms may be provided for staff. In those facilities built or altered since the ADA went into effect, single-user toilet rooms should have accessible features that could be useful during shelter operation. These features include an accessible entrance and turning and maneuvering spaces. These rooms should also have been built to allow grab bars, accessible controls, and accessible hardware to be easily installed.

As part of the planning for operating an emergency shelter, facilities operators should consider using an available staff toilet room, if provided, as a single-user or “family” toilet room. When provided in addition to large accessible toilet rooms, this type of facility permits a person with a disability to receive assistance from a person of the opposite sex.

M1. If a sign is provided at the toilet room entrance (e.g. Men, Women, Boys, Girls, etc.), is a sign with raised characters and Braille mounted on the wall adjacent to the latch side of the door and centered 60 inches above the floor? [ADA Standards § 4.1.3(16)(a)]

Yes

No

If No, install a sign with raised characters and Braille on the wall adjacent to the latch side of the door and centered 60 inches above the floor and leave the existing sign in place on the door if removing it will damage the door.

Note: an additional sign may be mounted on the toilet room door but this cannot be considered to be the accessible sign which must be mounted on the wall adjacent to the latch side of the door.

M2. Does the door to the toilet room provide at least 32 inches clear passage width when the door is open 90 degrees? [ADA Standards § 4.13.5]

Yes

No

M3. Is the hardware (e.g., lever, pull, etc.) usable with one hand without tight grasping, pinching, or twisting of the wrist? [ADA Standards § 4.13.9]

Yes

No

If No, add new accessible hardware or adapt/replace hardware.

M4. On the latch, pull side of the door, is there at least 18 inches clearance provided if the door is not automatic or power operated? [ADA Standards § 4.13.6; Fig. 25]

Yes

No

M5. If there is a raised threshold, is it no higher than 3/4 inch at the door and beveled on both sides? [ADA Standards §§ 4.1.6(3)(d)(ii); 4.13.8]

Yes

No

If No, replace threshold with one with beveled sides or add a sloped insert.

M6. Inside the room is there an area for a person who uses a wheelchair to turn around - either a 60-inch diameter circle or a "T"-shaped turn area? [ADA Standards §§ 4.22.3; 4.2.3]

Yes

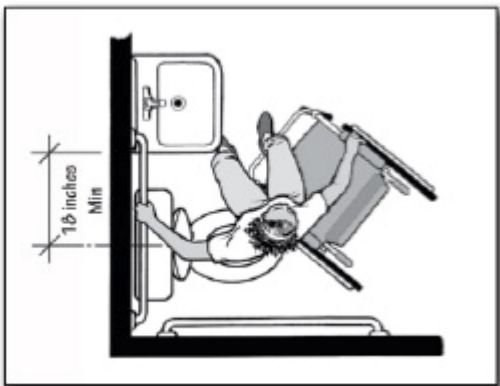
No

M7. If the door swings into the room, does the door swing not overlap the required clear floor space for the toilet or lavatory? [ADA Standards §§ 4.22.2; 4.2.4.1]

Yes

No

Note: In the figure below the clear floor space for the toilet extends at least 66 inches from the back wall.



**Plan view showing the minimum amount of space required between the toilet and the adjacent lavatory.**

M8. Is there at least 18 inches between the center of the toilet and the side of the adjacent lavatory? [ADA Standards § 4.16.2; Fig. 28]



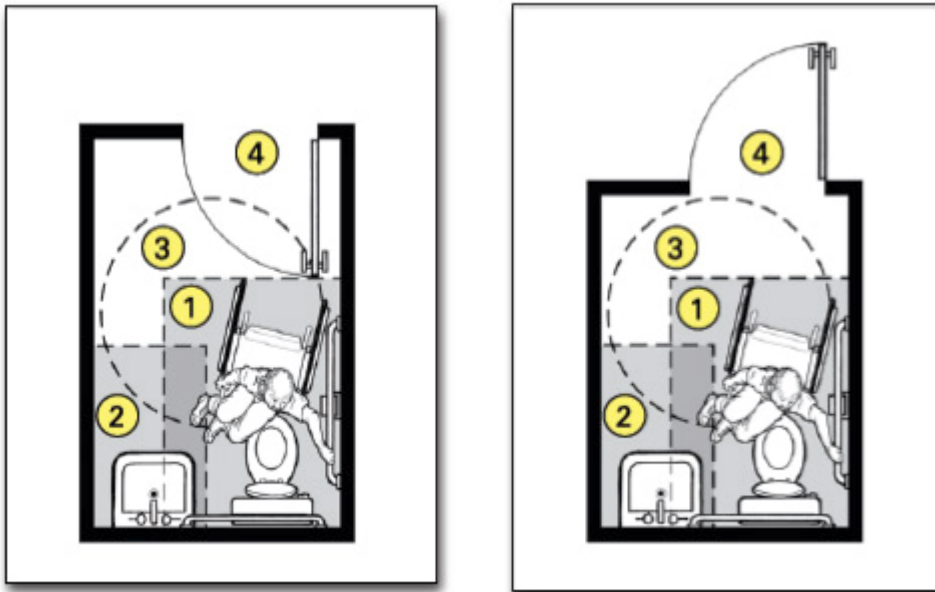
Yes

No

M9. Does the lavatory have at least a 29-inch-high clearance under the front edge and the top of the rim no more than 34 inches above the floor? [ADA Standards § 4.19.2]

Yes

No



**Plan view of a single-user toilet room showing the door swing not overlapping the dark toned area indicating the clear floor space for the toilet and lavatory. The door swing may overlap the turning space indicated by the circular area.**

**Notes:**

1. 48-inch minimum by 66-inch minimum clear floor space for toilet
2. 48-inch minimum by 30-inch minimum clear floor space for lavatory
3. 60-inch minimum turning space
4. door swing

M10. Are the drain and hot water pipes for the lavatory insulated or otherwise configured to protect against contact? [ADA Standards § 4.19.4]

Yes

No

M11. Does that lavatory have controls that operate easily with one hand, without tight grasping, pinching, or twisting of the wrist? [ADA Standards § 4.19.5]

Yes

No

M12. If a mirror is provided, is the bottom of the reflecting surface no higher than 40 inches above the floor or is a full length mirror provided? [ADA Standards § 4.19.6]

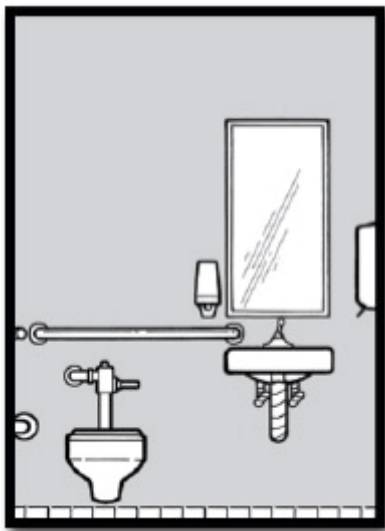
Yes

No

M13. For each type of dispenser, receptacle, or equipment, is there clear floor space at least 30 inches wide x 48 inches long adjacent to the control or dispenser (positioned either parallel to the control or dispenser or in front of it)? [ADA Standards §§ 4.23.7; 4.27.2; 4.2.5 and Fig. 5; 4.2.6 and Fig. 6]

Yes

No



**Front view of toilet, lavatory, mirror and soap dispenser**

M14. Is the operating control (switch, lever, button, or pull) for each type of dispenser or built-in equipment no higher than 54 inches above the floor (if there is clear floor space for a parallel approach) or 48 inches (if there is clear floor space for a front approach)? [ADA Standards §§ 4.23.7; 4.27.3; 4.2.5 and Fig. 5; 4.2.6 and Fig. 6]

Yes

No

M15. Are all built-in dispensers, receptacles, or equipment mounted so the front does not extend more than 4 inches from the wall if the bottom edge is between 27 inches and 80 inches above the floor? [ADA Standards §§ 4.23.7; 4.27; 4.4.1; Fig. 8]

Yes

No

M16. Is the centerline of the toilet 18 inches from the adjacent side wall? [ADA Standards §§ 4.16.2; 4.17.3]

Yes

No

M17. Is the top of the toilet seat 17 to 19 inches above the floor? [ADA Standards § 4.16.3]

Yes

No

M18. Is the flush valve located on the side adjacent to the lavatory? [ADA Standards § 4.16.5]

Yes

No

M19. Is a horizontal grab bar at least 40 inches long securely mounted on the adjacent side wall 33 to 36 inches above the floor with one end no more than 12 inches from the back wall? [ADA Standards §§ 4.16.4; 4.17.6]

Yes

No

M20. Is there a horizontal grab bar at least 36 inches long securely mounted behind the toilet 33 to 36 inches above the floor with one end no more than 6 inches from the side wall? [ADA Standards §§ 4.16.4; 4.17.6]

Yes

No

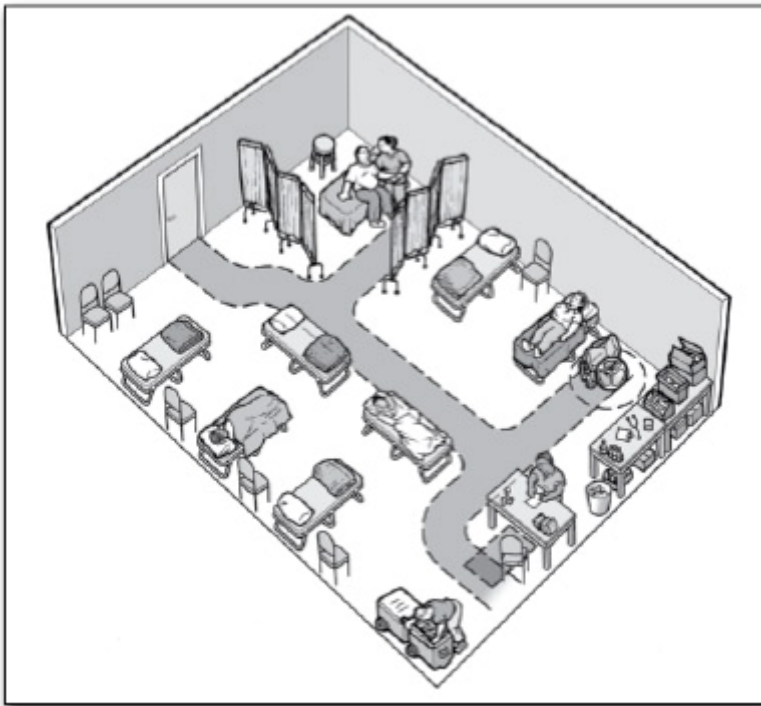
M21. If a coat hook is provided, is it mounted no higher than 54 inches above the floor for a side approach or 48 inches above the floor for a front approach? [ADA Standards § 4.25.3]

Yes

No

## **N. Health Units/Medical Care Areas**

In many schools, where emergency shelters are often located, nurses' rooms or other types of health care facilities may be provided. These health care facilities should be on an accessible route and have accessible features, including an accessible entrance, an accessible route to the different types of services offered within the medical care unit, turning and maneuvering spaces, and cots or beds that are at a height to which people who use mobility devices can easily transfer.



**An overhead view of a medical care area with a shaded pathway showing the accessible route shown and clear floor spaces.**

N1. Is there an accessible route, at least 36 inches wide (FBC – 44 inches wide if a required means of egress), that connects each of the shelter activity areas with the health units and medical care areas (it may narrow to 32 inches wide for up to 2 feet in length)? [ADA Standards § 4.3.2(3)]

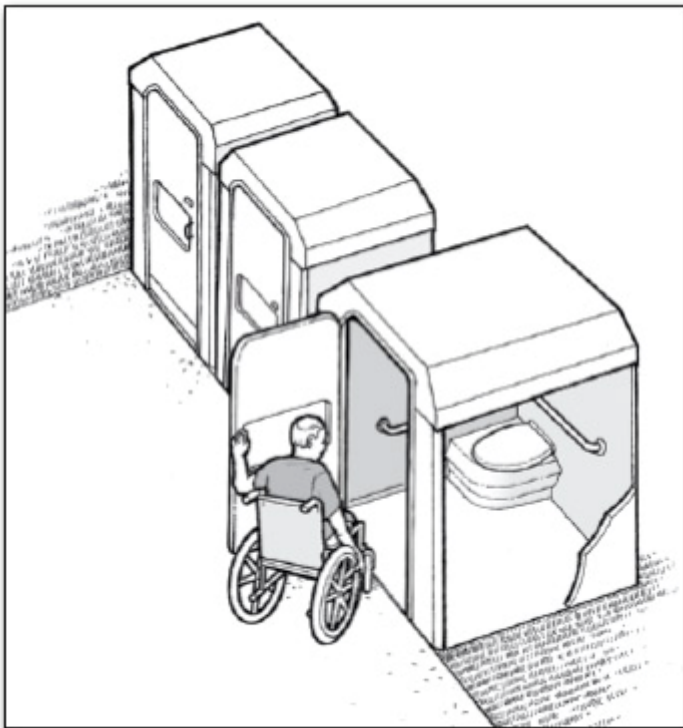
Yes

No

## O. Accessible Portable Toilets

Portable toilets are often used at emergency shelters to supplement permanent toilet facilities. When portable toilets are provided, at least one must be a unit with accessible features that is located on an accessible route connecting it with the shelter. For the entrance to an accessible portable toilet to be usable, there must either be no step or a ramp must be installed that extends from the hinge side of the door to at least 18 inches beyond the latch side of the door.

Accessible portable toilets should have similar features to a standard accessible toilet stall including an accessible door, side and rear grab bar, clear space next to the toilet, and maneuvering space.



**A person using a wheelchair enters an accessible portable toilet. The unit is positioned to provide a level entry from the accessible route.**

**Appendix L, Part 2:**

Chapter 7 Addendum 2: The ADA and Emergency Shelters: Access for All in  
Emergencies and Disasters

# ADA Best Practices Tool Kit for State and Local Governments

## Chapter 7 Addendum 2:

### The ADA and Emergency Shelters: Access for All in Emergencies and Disasters

---

One of government's primary responsibilities is to protect residents and visitors. Providing emergency shelter during disasters and emergencies is a basic way of carrying out this duty. Shelters are sometimes operated by government entities themselves. More commonly, though, shelters are operated for the state or local government by a third party – often the American Red Cross. Regardless of who operates a shelter, the Americans with Disabilities Act (ADA) generally requires shelters to provide equal access to the many benefits that shelters provide, including safety, food, services, comfort, information, a place to sleep until it is safe to return home, and the support and assistance of family, friends, and neighbors.<sup>1</sup> In general, the ADA does not require any action that would result in a fundamental alteration in the nature of a service, program, or activity or that would impose undue financial and administrative burdens.<sup>2</sup> This Addendum discusses some of the key issues that emergency managers and shelter operators need to address in order to comply with the ADA when they plan for and provide shelter during emergencies and disasters. Although this Addendum focuses primarily on issues affecting shelter residents with disabilities, these issues are also generally applicable to volunteers and employees with disabilities.

#### A. Advance Planning

- **Equal access requires advance planning.** During emergencies and disasters, people with disabilities sometimes have different, disability-related needs than other individuals. Many of these needs cannot be met during emergencies and disasters without advance planning. For example, if a person's health will be jeopardized without access to life-sustaining medication that must be refrigerated, an emergency shelter will be of little use to him unless he has access to the required medication and a way to keep it sufficiently cold. Resources of this kind will likely be unavailable unless emergency managers and shelter operators arrange to have them available well before an emergency or disaster occurs.

To provide equal access to people with disabilities, effective advance planning requires at least two steps: (1) identify the disability-related needs of the residents and visitors likely to be housed in a shelter, and (2) make the advance arrangements necessary to meet those needs in the event an emergency or disaster strikes. The most effective way for

emergency managers and shelter operators to ensure that advance planning addresses the needs of people with disabilities in their community is to involve community members with a wide variety of disabilities in the advance planning process. These individuals will be able to identify the types of disability-related needs that community residents and visitors are likely to have during emergencies as well as some of the community resources that may be available to help meet those needs.

To help in the advance planning process, the following sections of this Addendum identify some of the more common disability-related needs that shelter residents are likely to have. However, since people with different disabilities will typically have different needs, the issues addressed in this document are not exhaustive. Each community will have disability-related issues specific to its own residents and visitors that need to be identified and addressed. These issues are also likely to change over time as residents move into and out of communities and as changes occur in the types of equipment, medication, and technology that people with disability use.

<sup>1</sup> 28 C.F.R. §§ 35.130, 35.149.

<sup>2</sup> 28 C.F.R. §§ 35.130(b)(7), 35.150(a)(3), 35.164.

## **B. Accessibility**

- **Ensure that the sheltering program is accessible to people with disabilities.** Disasters and emergencies are unpredictable. Even the best emergency managers cannot say with certainty when an emergency will strike, how extensive the damage will be, and which shelters will remain available to house people who must evacuate their homes. For most people, any building designated as a shelter will meet their basic emergency needs so long as it provides a safe place to eat, sleep, and take care of personal hygiene needs. But an emergency shelter is of little use to a person using a wheelchair if it has steps at the entrance or toilet rooms she cannot use.

Under the ADA, emergency sheltering programs must not exclude or deny benefits to people with disabilities.<sup>3</sup> Emergency managers and shelter operators should therefore seek to ensure that shelters are physically accessible to people with disabilities, including people who use wheelchairs. Before designating a facility as an emergency shelter, emergency managers and shelter operators need to determine if it is accessible. Elements such as a shelter's parking, walkway to the entrance, entrance, toilets, bathing facilities, drinking fountains, sleeping area, food distribution and dining quarters, first aid/medical unit, emergency notification system, and other activity and recreation areas need to be examined for barriers. Government facilities built since 1992 and private business facilities built since 1993 are often the best candidates for emergency shelters because they were subject to ADA requirements for physical accessibility when they were built.<sup>4</sup> Some older facilities have been altered to provide physical accessibility<sup>5</sup> or can be made physically accessible by using temporary measures stored on site and readily available for use in the event an emergency occurs. Other older facilities are poor candidates for emergency shelters because they have barriers that are too expensive or infeasible to remove. For guidance on emergency shelter accessibility, please see the Department of



Justice’s “ADA Checklist for Emergency Shelters” at [www.ada.gov/pcatoolkit/chap7shelterchk.htm](http://www.ada.gov/pcatoolkit/chap7shelterchk.htm). The checklist includes two assessment tools to ensure that emergency shelters provide access to all: (1) a preliminary checklist that will help emergency managers and shelter operators decide if a facility has the characteristics that make it a good candidate for a potential emergency shelter, and (2) a more detailed checklist that will help identify and remove the most common barriers to physical accessibility.

**Emergency managers and shelter operators need to ensure that sheltering programs are accessible to people with disabilities, including individuals who use wheelchairs.**

<sup>3</sup> 28 C.F.R. §§ 35.130, 35.149.

<sup>4</sup> 28 C.F.R. § 35.151(a) (for public facilities); 28 C.F.R § 36.406 (for private facilities that are subject to the requirements of Title III of the ADA because they are public accommodations or commercial facilities).

<sup>5</sup> 28 C.F.R. § 35.151(b) (for public facilities); 28 C.F.R. §§ 36.402 - 36.405 (for private facilities that are subject to the requirements of Title III of the ADA because they are public accommodations or commercial facilities).

### **C. Eligibility Criteria**

Shelters are usually divided into two categories: (1) “mass care” shelters, which serve the general population, and (2) “special needs” or “medical” shelters, which provide a heightened level of medical care for people who are medically fragile. Special needs and medical shelters are intended to house people who require the type and level of medical care that would ordinarily be provided by trained medical personnel in a nursing home or hospital.

- **House people with disabilities in mass care shelters.** Emergency managers and shelter operators sometimes wrongly assume that people need to be housed in special needs or medical shelters simply because they have a disability. But most people with disabilities are not medically fragile and do not require the type or level of medical care that special care and medical shelters are intended to provide. The ADA requires people with disabilities to be accommodated in the most integrated setting appropriate to their needs,<sup>6</sup> and the disability-related needs of people who are not medically fragile can typically be met in a mass care shelter. For this reason, people with disabilities should generally be housed with their families, friends, and neighbors in mass care shelters and not be diverted to special needs or medical shelters.

To comply with the ADA’s integration requirement, emergency managers and shelter operators need to plan to house people with a variety of disabilities in mainstream mass care shelters, including those with disability-related needs for some medical care, medication, equipment, and supportive services. Emergency managers and shelter operators must also ensure that eligibility criteria for mass care shelters do not unnecessarily screen out people with disabilities who are not medically fragile based on erroneous assumptions about the care and accommodations they require.

- **Respect the right of people with disabilities to make choices about where to shelter.** In some communities, emergency managers have designated shelters specifically for individuals with disabilities or individuals with a specific type of disability. For example, a community with a school for students who are deaf may designate that facility as an emergency shelter for people who are deaf. While the ADA does not prohibit offering these types of emergency shelters,<sup>7</sup> it generally does prohibit emergency managers and shelter operators from requiring people with disabilities or people with a specific type of disability to stay in such shelters.<sup>8</sup> The ADA requires emergency managers and shelter operators to accommodate people with disabilities in the most integrated setting appropriate to their needs, which is typically a mass care shelter.
- **House people with disabilities in mass care shelters even if they are not accompanied by their personal care aides.** Some people with disabilities use personal care assistance for activities of daily living, such as eating, dressing, routine health care, and personal hygiene needs. One question that frequently arises is whether people with disabilities who use attendant care can be appropriately housed in mass care shelters. In most instances, they can. Most people with disabilities who use attendant care are not medically fragile and do not require the heightened level of medical care provided in a special needs or medical shelter.

In the past, some shelter operators maintained policies that prevented people with disabilities who regularly use attendant care from entering mass care shelters unless they were accompanied by their own personal care attendants. These policies denied access to many people with disabilities.

During emergencies, many personal care attendants – like other people – evacuate or shelter with their own families instead of staying with their clients. Shelter operators should provide support services in mass care shelters to accommodate people with disabilities who are not medically fragile but need some assistance with daily living activities unless doing so would impose an undue financial and administrative burden. Such assistance can be provided by medical personnel or trained volunteers.

**Local governments and shelter operators may not make eligibility for mass care shelters dependent on a person’s ability to bring his or her own personal care attendant.**

- **Make arrangements in advance to ensure that special needs and medical shelters have sufficient numbers of adequately trained medical staff and volunteers.** Special needs and medical shelters house people with disabilities who require the heightened medical care that is ordinarily provided in nursing homes and hospitals. However, in the past, these shelters have often had too few qualified staff – or relied too heavily on volunteers with minimal training – to provide adequate care to the medically fragile people they house.

Advance planning is the only way emergency managers and shelter operators can secure enough trained medical personnel and adequately trained volunteers to ensure the safety and comfort of residents of special needs and medical shelters.

- **Keep families together whenever possible, even in special needs and medical shelters.** Family members provide each other the support and assistance necessary to cope with emergencies and disasters. During these difficult times, separation from family members increases loneliness, worry, and additional stress. But while most families have been able to stay together during emergencies, individuals with disabilities have often been unnecessarily separated from their families because many special needs and medical shelters do not allow them to be accompanied by more than one person.

In disasters and emergencies, people are ordinarily allowed to shelter with their families. This benefit needs to be available to persons with disabilities as it is for everyone else. Of course, some people in special needs and medical shelters may need to be housed in medical wards apart from their families because of critical medical needs, but their families should still be housed nearby.

<sup>6</sup> 28 C.F.R. § 35.130(d).

<sup>7</sup> 28 C.F.R. § 35.130(b)(2) - (c).

<sup>8</sup> 28 C.F.R. § 35.130(b)(2), (e)(1).

#### **D. Reasonable Modifications**

The ADA generally requires emergency managers and shelter operators to make reasonable modifications to policies, practices, and procedures when necessary to avoid discrimination.<sup>9</sup> A reasonable modification must be made unless it would impose an undue financial and administrative burden.<sup>10</sup> The following are examples of reasonable modifications that emergency managers and shelter operators will generally need to make:

- **Modify “no pets” policies to welcome people who use service animals.** Many emergency shelters do not allow residents or volunteers to bring their pets inside. But shelters must generally modify “no pets” policies to allow people with disabilities to be accompanied by their service animals.

A service animal is not a pet. Under the ADA, a service animal is a dog (or in some cases a miniature horse) that is individually trained to provide assistance to a person with a disability. Most people are familiar with dogs that guide people who are blind or have low vision. But there are many other functions that service animals perform for people with a variety of disabilities. Examples include alerting people who are deaf or hard of hearing to sounds; pulling wheelchairs; carrying or retrieving items for people with mobility disabilities or limited use of arms or hands; assisting people with disabilities to maintain their balance; and alerting people to, and protecting them during, medical events such as seizures.

How can a service animal be identified? Service animals come in all breeds and sizes. Many are easily identified because they wear special harnesses, capes, vests, scarves, or patches. Others can be identified by the functions they perform for people whose disabilities can be readily observed. When none of these identifiers are present, shelter staff may ask only two questions to determine if an animal is a service animal: (1) “Do

you need this animal because of a disability?” and (2) “What tasks or work has the animal been trained to perform?” If the answers to these questions reveal that the animal has been trained to work or perform tasks for a person with a disability, it qualifies as a service animal and must generally be allowed to accompany its owner anywhere other members of the public are allowed to go, including areas where food is served and most areas where medical care is provided. Questions about the nature or severity of a person’s disability or ability to function may not be asked. It is also inappropriate to question a person’s need for a service animal or to exclude a service animal on the grounds that shelter staff or volunteers can provide the assistance normally provided by the service animal.

- **Modify kitchen access policies for people with medical conditions that may require access to food.** Most shelter operators restrict residents’ and volunteers’ access to the kitchen to preserve food and beverage supplies and maintain efficient kitchen operations. But people with medical conditions such as diabetes may need immediate access to food to avoid serious health consequences. Shelter operators need to make reasonable modifications to kitchen policies so that residents and volunteers with disability-related needs can have access to food and beverages when needed.
- **Modify sleeping arrangements to meet disability-related needs.** To maximize efficiency, shelter operators typically provide one standard type of cot or mat for use by shelter residents. However, some people have disability-related needs for cots to be modified or may need to sleep on cots or beds instead of on mats placed on the floor. For example, a person with muscular dystrophy may require a cot with a very firm mattress to provide the physical support needed to facilitate breathing. Similarly, many people with mobility disabilities will be unable to use a sleeping mat placed on the floor. For example, many people using wheelchairs or scooters will be unable to safely transfer on and off a cot or bed unless it is firmly anchored so it does not move and has a firm sleeping surface that is 17 - 19 inches above the floor. Shelter operators need to establish procedures that people with disabilities can use to request reasonable modifications to sleeping arrangements.

<sup>9</sup> 28 C.F.R. § 35.130(b)(7).

<sup>10</sup> 28 C.F.R. § 35.130(b)(7).

## **E. Effective Communication**

From the moment people begin to arrive at a shelter, good communication between staff, volunteers, and residents is essential. Many shelter residents and volunteers might have communication-related disabilities, including those who are deaf or hard of hearing and those who are blind or who have low vision. People with mental retardation or psychiatric disabilities might also have communication difficulties in certain circumstances, such as registering, filling out applications for benefits, or trying to understand what benefits and services are available.

Under the ADA, shelter operators must provide “effective communication” to people with disabilities unless doing so would result in a fundamental alteration or would impose undue

financial and administrative burdens.<sup>11</sup> Shelters that are part of a state or local government sheltering program must give “primary consideration” to the type of auxiliary aid or service preferred by the person with a disability;<sup>12</sup> they must defer to that choice unless another equally effective method of communication is available or the preferred method would impose an undue financial and administrative burden or fundamental alteration.<sup>13</sup> This requirement applies even if a third party operates the shelter under an arrangement with the state or local government.

Advance planning is critical to ensuring effective communication during an emergency. Without such planning, it may be difficult or impossible to locate auxiliary aids and services and have them ready for use at the shelter. Advance planning will also alleviate the expense and burdens associated with providing auxiliary aids.

- **Provide alternate format materials for people who are blind or who have low vision.** People who are blind or have low vision may request documents and brochures in alternate formats (Braille, large print, or audio recording). Generally, shelter supplies should include alternate format versions of documents that are routinely made available to shelter residents. Having alternate formats available for distribution during an emergency requires advance planning.

When documents are prepared on the spot and alternate formats cannot be prepared in advance or produced as needed, shelter operators are still required to provide effective communication through alternate means.<sup>14</sup> Often, the most effective solution in an emergency is to provide a person to read printed documents and, where applicable, someone to help fill out forms. People who serve as readers or provide assistance filling out forms must be “qualified” – in the context of an emergency shelter, this means being capable of and willing to read materials and complete forms as instructed by the person with a disability.

- **Ensure that audible information is made accessible to people who are deaf or hard of hearing.** In emergency shelters, most information is conveyed through oral announcements. Shelter operators must ensure that people who are deaf or hard of hearing have access to this information in a timely and accurate manner. In some circumstances, qualified sign language or oral interpreters may be required by the ADA. In others, posting messages and announcements in written format on a centrally located bulletin board, or writing notes back and forth with residents who are deaf or hard of hearing, may suffice.

The type of auxiliary aid or service required in a specific situation depends on several factors, including the length, complexity, and importance of the communication and the person’s language skills and history. For example, handwritten notes will not communicate information effectively to a person who cannot read. Similarly, providing a sign language interpreter will not be effective for a person who is hard of hearing and does not understand sign language. If it becomes an undue financial and administrative burden to obtain qualified sign language or oral interpreters at a shelter, then the ADA does not require them. However, advance planning can significantly reduce the costs and administrative burdens of making interpreters available.

- **Provide a TTY for the use of people who are deaf or hard of hearing.** Many people in shelters use telephones to apply for disaster relief benefits, arrange for transitional housing, and speak to family and friends. People who can use standard voice telephones typically make use of shelter telephones or cellular phones for this purpose. But without access to a teletypewriter (TTY), people who are deaf or hard of hearing and those who have speech disabilities are unable to communicate with others over the telephone.

<sup>11</sup> 28 C.F.R. § 35.160.

<sup>12</sup> 28 C.F.R. § 35.160(b)(2).

<sup>13</sup> 28 C.F.R. § 35.164.

<sup>14</sup> 28 C.F.R. § 35.164.

## F. Shelter Environment

- **Offer orientation and wayfinding assistance to people who are blind or have low vision.** Until they become familiar with the shelter layout, blind people and those with low vision may have difficulty locating different areas of the shelter. Even after they are oriented to the shelter environment, changes in furniture layout or the addition or removal of cots may be disorienting to people who rely on these landmarks to find their way around. When they arrive at a shelter, people who are blind and those with low vision might need assistance orienting themselves to the shelter layout and locating pathways to sleeping areas, toilet rooms, and other areas of the shelter they may wish to use. Offer, but do not insist, on providing orientation and wayfinding assistance. Some people who are blind or have low vision need such assistance. Others can, and prefer to, find their own way.
- **Maintain accessible routes.** Cots and other furniture need to be placed to ensure that accessible routes – routes that people who use wheelchairs, crutches, or walkers can navigate – connect all features of the shelter. For instance, accessible routes need to connect the sleeping quarters to the food distribution and dining quarters, to the toilet rooms and bathing facilities, activity areas, etc. Generally, an accessible route is 36 inches wide, except at doors and for short distances, when it can be narrower, and where it turns, when it must be wider. More guidance on accessible routes is provided in the “ADA Checklist for Emergency Shelters” at [www.ada.gov/pcatoolkit/chap7shelterchk.htm](http://www.ada.gov/pcatoolkit/chap7shelterchk.htm).
- **Eliminate protruding objects in areas where people can walk.** Furniture and other items should be positioned to direct pedestrians who are blind or have low vision safely away from overhead or protruding objects. This requirement extends beyond the “accessible route” and applies throughout the shelter environment to any place where a person can walk. Hazards posed by protruding and overhead objects can typically be eliminated by placing a cane-detectable barrier on the floor beneath or next to them. But care should be taken so cane-detectable barriers do not block accessible routes or the clear floor space that people using mobility devices need to access common protruding objects such as drinking fountains. For more guidance on protruding objects, please see

please see the “ADA Checklist for Emergency Shelters” at [www.ada.gov/pcatoolkit/chap7shelterchk.htm](http://www.ada.gov/pcatoolkit/chap7shelterchk.htm).

- **Consider low-stimulation “stress-relief zones.”** The stress from the noise and crowded conditions of a shelter – combined with the stress of the underlying emergency – may aggravate some disability-related conditions, such as autism, anxiety disorders, or migraine headaches. Without periodic access to a “quiet room” or quiet space within a larger room, some people with disabilities will be unable to function in a shelter environment. In locations where a school gym serves as the emergency shelter, a nearby classroom can provide the necessary relief from noise and interaction that some shelter residents and volunteers with disabilities will need. Other shelter residents and volunteers may want a break from the noise and crowds. But quiet spaces are limited, they should be made available on a priority basis to people whose disabilities are aggravated by stress or noise.
- **Consult residents with disabilities regarding placement of their cots.** Some individuals will have disability-related needs that require accommodation when assigning the location of their cot. For instance, a person who uses a wheelchair, crutches, or a walker may need a cot located close to an accessible toilet room. Since an assigned cot may not be identifiable by touch, a blind person may need a cot placed in a location that she can easily find. A person with low vision may need his bed located close to light so he can see or away from bright light that aggravates his eyes. Likewise, someone who is deaf or hard of hearing may need a cot placed away from visual distractions that would prevent him from sleeping.

## G. Supplies

- **Provide an effective way for people to request and receive durable medical equipment and medication.** Despite advance planning, some people with disabilities will find themselves in shelters without a supply of the medications or medical equipment they need. For example, some medical insurance plans prohibit people from purchasing medication until their existing supply is almost gone. Other people may be required to evacuate without medication or medical equipment or be inadvertently separated from medication or medical equipment during evacuation. Emergency managers and shelter operators need to plan and make arrangements in advance so persons with disabilities can obtain emergency supplies of medications and equipment.
- **Whenever possible, provide refrigeration for certain types of medication.** Many people with disabilities need medication that must be refrigerated. Shelters need to have a safe and secure refrigerated location where medications can be stored and accessed when needed.
- **If electricity is available, give priority to people with disabilities who use ventilators, suctioning devices, and other life-sustaining equipment.** Some people with disabilities require ventilators, suctioning devices, or other life-sustaining equipment powered by electricity. Without electrical power, many of these individuals cannot survive. When electrical power is available, access should be given to people who depend on electrically



powered equipment to survive.

Many people with disabilities depend on battery-powered wheelchairs and scooters for mobility. The batteries in these mobility aids must frequently be recharged, or they will stop functioning. Without these mobility aids, many people with disabilities will lose their ability to move about, they may be unable to participate in some services offered by the shelter, and they may need to depend more heavily on assistance from others. When possible, provide these individuals the opportunity to charge the batteries that power the equipment they use for mobility and independence.

- **Provide food options that allow people with dietary restrictions to eat.** Because of disabilities, some people are unable to eat certain types of food. For example, people with diabetes must restrict their intake of carbohydrates. Other people have severe allergies to common food ingredients, such as peanut oil and byproducts. In planning food supplies for shelters, emergency managers and shelter operators need to consider foods and beverages for people with common dietary restrictions.
- **Provide emergency supplies that enable people with disabilities to care for their service animals.** Many people with disabilities rely on service animals to do things they cannot do themselves. But when evacuating during an emergency, some individuals will be unable to transport enough food and water for their service animals. Shelter operators need to make food and water available so individuals can feed and care for their service animals. Shelter operators should also make reasonable modifications to security screening procedures so that people with disabilities are not repeatedly subjected to long waits at security checkpoints simply because they have taken their service animals outside for relief.

## H. Transitions Back to the Community

- **Provide people with disabilities a reasonable amount of time and assistance to locate appropriate housing.** Shelters provide temporary refuge during and after an emergency until people can return home or arrange an alternative place to live. In some instances, shelter operators have required individuals with disabilities to move to hospitals, nursing homes, or other institutions when these individuals could not locate accessible housing or the supportive services they needed to live in their own home as quickly as other individuals. As a result, some people with disabilities who once lived independently in their own homes found themselves institutionalized soon after a disaster occurred.

The ADA generally requires people with disabilities to receive services in the most integrated setting appropriate to their needs unless doing so would result in a fundamental alteration in the nature of services or impose undue financial and administrative burdens.<sup>15</sup> To comply with this requirement and assist people with disabilities in avoiding unnecessary institutionalization, emergency managers and shelter operators may need to modify policies to give some people with disabilities the time and assistance they need to locate new homes.

## I. Other Resources



As discussed above, the ADA requires that people with disabilities have equal access to shelters and the benefits they provide. Providing equal access to people with different disabilities can involve very different issues. This document discusses a few of the most common issues and how they can be addressed. Other issues are addressed in Chapter 7 of the “ADA Best Practices Tool Kit for State and Local Governments,” “The ADA Guide for State and Local Governments: Making Emergency Preparedness and Response Programs Accessible to People with Disabilities,” the “ADA Checklist for Emergency Shelters,” and other technical assistance materials that are available on the Department of Justice’s ADA Home Page at [www.ada.gov](http://www.ada.gov).

<sup>15</sup> 28 C.F.R. § 35.130(d).